

## Paravirtualization of Geophysical Hardware for Mobile Clients (Android, iOS)

*Bernhard Friedrichs, metronix,*

*Braunschweig, Germany*

*bernhard.friedrichs@metronix.de*

The **MVC** (model view controller) pattern is widely used in programming frameworks for data visualization. User interfaces of older geophysical systems may use the hardware and their response messages as controller (C) and visualize the system's status on the GUI (V, graphical user interface).

Simulating the hardware by **paravirtualization** (a not complete virtualization) allows the GUI to be predictive and to reduce the necessary steps for operating complex systems. This is specially desired when using mobile clients with very small screens.

Step one is the creation of a **virtual system library**

The library represents all major hardware components as classes.

Each class contains its own logic; data like sampling frequencies is assembled from real configuration data of the hardware (**model**).

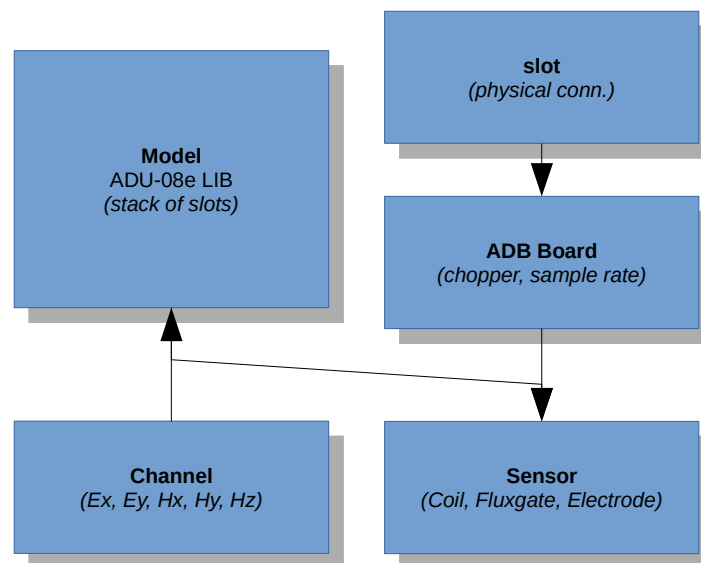

Using Qt's signal & slot concept each class can emit and receive status information (**controller**).

Class inheritance is shown above.

At a running stage the library is used to represent the physical hardware. A GUI programmer can now focus on the GUI interaction with the system (**view**) without being connected to physical hardware in his office. This is a significant advantage already.

The biggest effect however is that the library controls the GUI, and the logic behind this is not implemented inside the GUI module.

The library may emit “good, fair, critical” and in the case of the mobile app the buttons turn green, yellow and red accordingly.

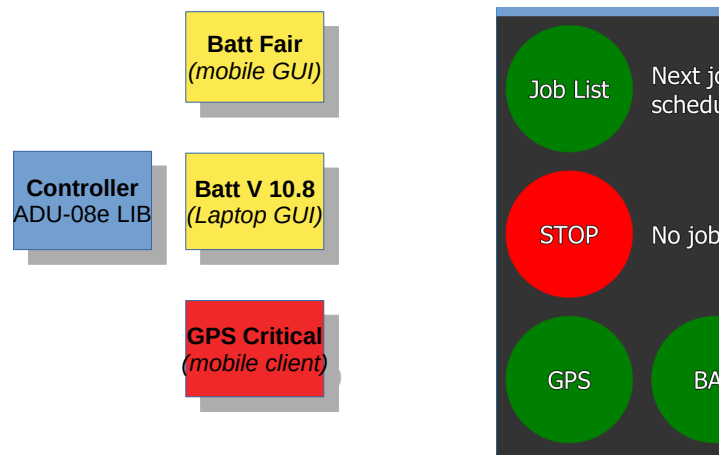

In case the library decides to change fair from 10.8 V to 10.6 V for the battery status the GUI code stays untouched but the button turns yellow now at a measured voltage of 10.6 V.

That drastically reduces cost of changes later.

Another aspect is the re-usage for other applications. As shown in the figure above, the library may emit two signals (battery fair and battery 10.8) at the same time. A different **view** can be connected for other purpose (a more detailed program for laptop usage).

## Summary

A **MVC** framework can be realized for controlling a geophysical data logger by creating a paravirtualized library representing the hardware.

The library can be maintained by an engineer easily, the GUI can be written externally. Changing the library’s messages changes the GUI behavior without need of editing the GUI code.

Re-usage of the library or other purposes (such as creating job lists for example or time series format conversion) is a valuable strategy.