

Topic	Strainmeters
Author	Walter Zürn, Black Forest Observatory, Universities Karlsruhe/Stuttgart, Heubach 206, D - 77709 Wolfach; E-mail: walter.zuern@kit.edu
Version	September 2009; DOI: 10.2312/GFZ.NMSOP-2_IS_5.1

	page
1 Introduction	1
2 Types of strainmeters	1
2.1 Linear strainmeters	1
2.2 Volumetric strainmeters	3
3 Properties	3
3.1 Sensitivity	3
3.2 Frequency response	4
3.3 Calibration	4
3.4 Direction sensitivity	5
3.5 Local arrays of linear strainmeters	5
3.6 Local phase velocity	5
3.7 Effects of local heterogeneity	6
4 Some results	6
5 Strain- vs. inertial seismometers	8
6 References	10

1 Introduction

In contrast to inertial seismometers, which respond to ground acceleration and thus to the second derivative of the displacement with respect to time, strain-seismometers, commonly termed extensometers or strainmeters, respond to the spatial derivatives of the displacement field of the incoming seismic wave or in other words, to a combination of the components of the wave's strain tensor. For this reason, strainmeters are inherently instruments which are sensitive to phenomena with "zero" (i.e., very low) frequency and thus particularly suitable for studying crustal deformations due to solid Earth tides and normal mode oscillations of the Earth. More precisely, linear strainmeters record the changes of the distance between the two points at which the instrument is fixed to the ground, while volumetric strainmeters (dilatometers) record the changes of a volume standard which is imbedded in the ground. An excellent, thorough and comprehensive review of strainmeters with an extensive bibliography was written by Agnew (1986) and is still up to date. Strainmeters were introduced into seismology already by Milne (1888).

2 Types of strainmeters

2.1 Linear strainmeters

This is the most frequently deployed type of strainmeter. The changes $dL(t)$ with time t of a fixed distance L between two points of the Earth are measured with the help of some length

standard. Only a handful of strainmeters ever measured non-horizontal strains and all these were vertical, by far the majority was measuring horizontal strain. Agnew (1986) distinguishes rod strainmeters, wire strainmeters and laser strainmeters (see Figure 1).

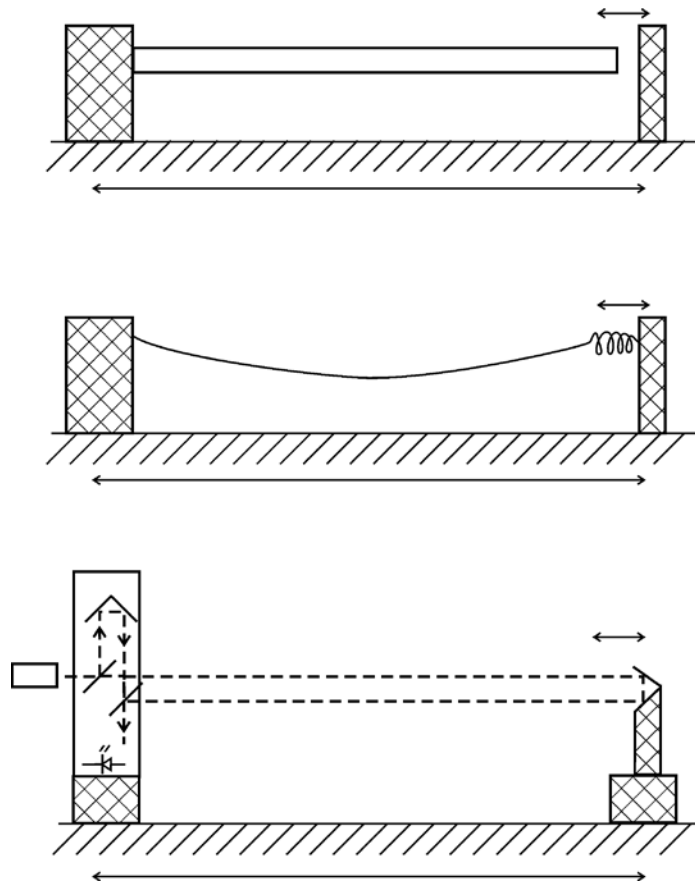

Figure 1 Schematics of the most frequent strainmeter designs. From top to bottom: rod-, (tensioned) wire- and laser strainmeters. The top two must be equipped with displacement transducers at the right. The bottom sketch indicates the laser, two beam splitters, one corner cube reflector and some sensor (symbol of photodiode) able to detect the change in the interference fringes due to the relative motion of the corner cube reflector on the pedestal to the right.

The length standard should be very stable against all kinds of environmental variables, especially temperature, air pressure and humidity. Because of these requirements, rods are mostly made of quartz, invar or superinvar and wires from invar or carbon fiber. Long rods somehow must be supported without friction, while wires must be tensioned. The length changes are detected by displacement or velocity transducers very similar to the ones used in modern inertial seismometers (see 5.3.7 and 5.3.8). One example of an Invar-rod strainmeter and its installation is described by Fix and Sherwin (1970). A frequently used type of wire strainmeter is described by King and Bilham (1976) and an installation in Widmer et al. (1992). Very short rod strainmeters can be placed in borehole packages, which then must be cemented to the borehole wall. An instrument of this type is described by Gladwin (1984). Laser strainmeters use the wavelength of light as a length standard and an unequal-arm

Michelson interferometer for detection of strains. The interference fringes between the light beams along the long arm (the measuring distance L) and a short reference arm are observed with different methods, details of which can be found in the references given by Agnew (1986). It is clear that simple fringe counting necessitates L to be very large to obtain high enough sensitivity: the wavelength of light is of the order of 500 nm, which is 10 times the amplitude of the Earth tide if L equals 1 m. Therefore the fringe counting laser strainmeters at Pinion Flat Observatory in California are more than 700 m long (Agnew, 1986; Wyatt et al., 1982, Agnew et al. 1989). Two other laser strainmeters with refined methods to determine the length changes using the fringes are described by Levine and Hall (1972) and by Goultly et al. (1974). The smallness of the expected signals with respect to the local noise from changes in the environmental conditions necessitates either installation deep underground in mines or boreholes or possibilities for anchoring the mounts to points deep in the ground (Wyatt et al., 1982). A typical installation depth with hope for success is larger than about 30 m below surface. Shielding the instruments is also mandatory and not as easy as for the much smaller inertial seismometers.

2.2 Volumetric strainmeters

Volumetric strainmeters or dilatometers measure the change $dV(t)$ of a certain volume V . A borehole instrument of this kind was constructed by Sacks et al. (1971) and widely deployed, especially in Japan. The volume changes are sensed by a liquid-filled tube which is cemented into the borehole. The deformation of the volume causes the liquid to expand or contract bellows, the movement of which is transmitted by a lever arm to displacement transducers. In passing it should be mentioned that water wells drilled into confined aquifers act as sensors for the strain tensor in their vicinity, because applied strains force water in and out of the well, if it is open to the aquifer. Either the level of the water surface or water pressure at a constant depth are measured (e.g. Kämpel, 1992).

3 Properties

3.1 Sensitivity

A typical strain amplitude dL/L (no dimension!) of the solid Earth tide is 50 nano ($50 \cdot 10^{-9}$), while Widmer et al. (1992) reported 10 pico (10^{-11}) for the fundamental toroidal mode ${}_0T_2$ of the Earth (see Fig. 2.22) excited by the 1989 Macquarie-Ridge event with a moment magnitude of 8.2. Note that these numbers correspond to one wavelength of (red) light in 10 m and 50 km, respectively. It is obvious that the necessary resolution of the transducer depends critically on the dimension of the strainmeter, i. e. the longer L , the less resolution is needed to achieve a certain resolution in strain. Agnew (1986) shows a power spectrum of Earth's strain noise (Figure 2) and describes the sources of the noise as follows: above 0.5 Hz body wave energy, machinery and wind-blown vegetation, between 0.05 and 0.5 Hz marine microseisms with high temporal variability and from 1 mHz to 0.05 Hz atmospheric pressure changes deforming the ground (wind turbulence, infrasound) (see 4.3). Below 1 mHz the sources are hard to identify, possibilities being thermoelastic deformations, pore pressure and groundwater changes (Evans and Wyatt, 1984), or air pressure changes. Instrumental effects play an important role at the lowest frequencies (drift) and are not easily ruled out (Zadro and Braitenberg, 1999).

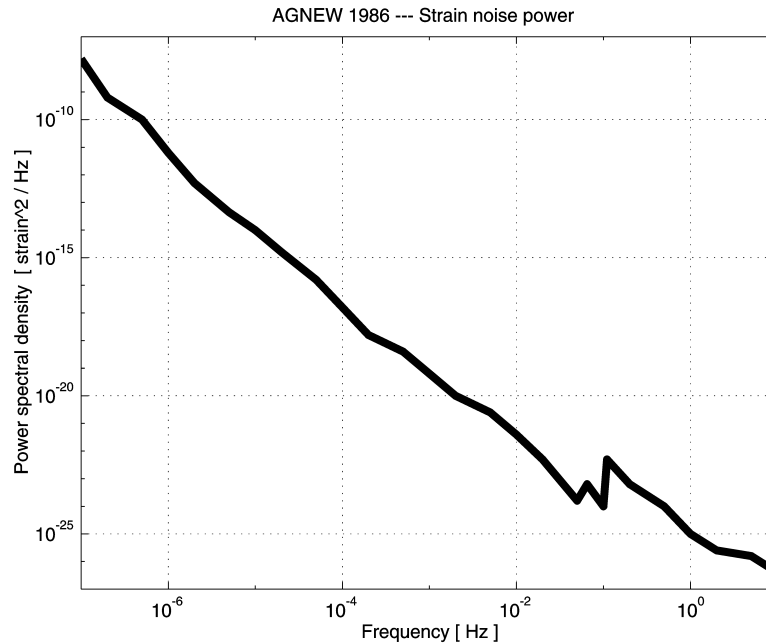

Figure 2 Power spectral density in (strain squared)/Hz as published by Agnew (1986). This is from the 730 m-NW laser horizontal strainmeter at Pinion Flat, California. This instrument is installed at the surface, but referenced with "optical anchors" to a depth of 30 m (Wyatt et al. 1982). See discussion of noise sources in text.

3.2 Frequency response

Lomnitz (1997) discusses the amplification of strainmeters for the case, when the seismic wavelength becomes comparable to the length L . However, the wavelengths of seismic waves are normally much larger than L , therefore the dependence of the amplification on the wavelength can be neglected in all but a few exceptional cases. So, basically strainmeters are extremely broadband instruments whose range extends from zero frequency to frequencies of 1 Hz and higher. However, the upper limit of this range depends very critically on the design of the individual instrument since all devices possess parasitic resonances at high frequencies.

3.3 Calibration

The method for absolute calibration of a strainmeter depends on the individual instrument. In-situ calibration is highly recommended, that is calibration of the installed device is preferable to calibration calculation from components calibrated in the laboratory. Small displacements of that end of a linear strainmeter, which is fixed to the rock simulates ground motion. Uncertainties arise from the definition of the effective length L , because basically the piers are part of the instruments and have some extent in length. Greater difficulties arise for instruments which have to be cemented into a borehole (Sacks-Evertson dilatometers, tensor strainmeters), because the strains in the ground are transferred to the actual sensor through the borehole wall, the casing and the cement. In these cases a very rough calibration can be obtained with the help of Earth tide strains, which are theoretically at least known to the order of magnitude. However, very local heterogeneities may complicate this method (King et al., 1976).

3.4 Direction sensitivity

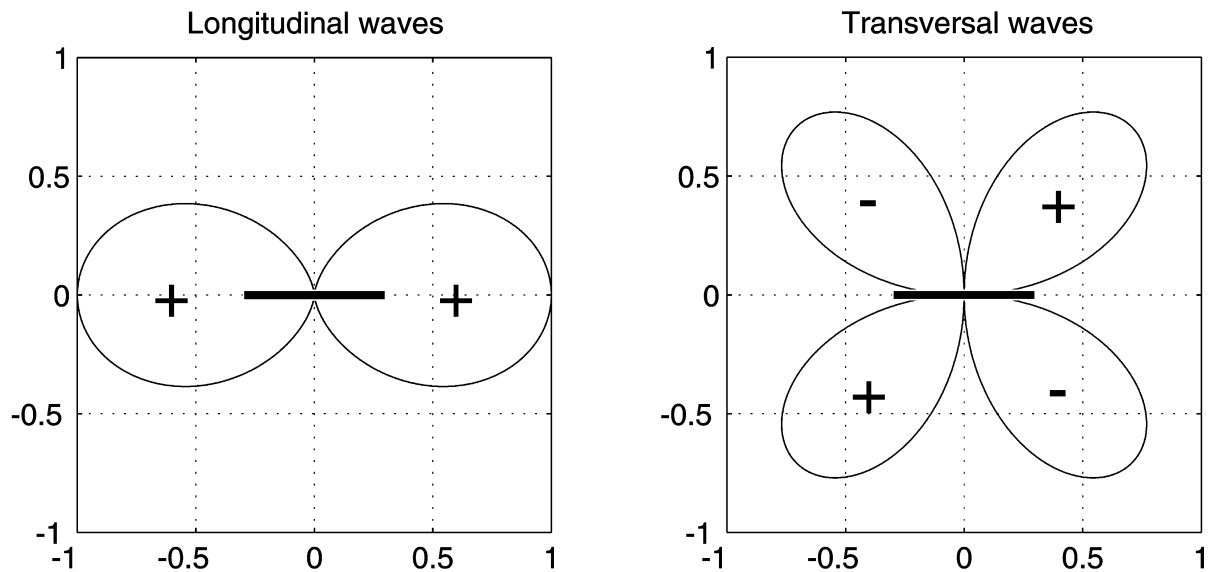

Figure 3 Relative direction sensitivity of linear strainmeters to apparent longitudinal (left) and apparent transversal (right) elastic waves. The strainmeter is indicated by the thick horizontal bar in the center of diagrams. Note that in both cases the strainmeter response is identical for opposite arrival directions.

Dilatometers naturally have isotropic direction sensitivity, the signal does not depend on the direction of arrival of the seismic wave. Figure 3 shows the directional sensitivity patterns of a horizontal strainmeter for longitudinal (left panel) and transversal (right panel) elastic waves. The thick solid bar in the center of each panel indicates the strainmeter. If p is the angle between the arrival direction of the wave and the direction L , these functions are described by $\cos(p)\cos(p)$ for longitudinal, by $\sin(2p)$ for transversal waves. This means, that when looking into a certain arrival direction, the sign of the output does not depend on whether the wave comes from the front or from behind. Near the free horizontal surface, vertical strain is proportional to the areal strain (also direction independent), therefore vertical strainmeters provide less information than horizontal strainmeters.

3.5 Local arrays of linear strainmeters

If three (or more) horizontal linear strainmeters with different azimuth are deployed at one site, any horizontal component of the strain tensor associated with the incoming wave can be determined from a particular combination of the calibrated signals. Widmer et al. (1992) use this property to demonstrate, that toroidal free oscillation peaks in shear strain spectra do not exist in the areal strain spectrum, a theoretically required result.

3.6 Local phase velocity

Assuming a plane elastic wave is recorded by a linear strainmeter and an inertial seismometer at the same station, then one can in principle derive the phase velocity of the wave at this

location. This is due to the fact that the inertial seismometer's output amplitude is proportional to the second derivative of displacement with time (frequency squared), while the strainmeter output is proportional to the spatial derivative (wavenumber).

Depending on the components one can derive equations which relate the frequency-dependent phase velocity with the amplitude spectra of both instruments (Mikumo and Aki, 1964). However, this attractive method has not found many applications, because of local deviations of the deformation field from a simple plane wave (Sacks et al., 1976; King et al., 1976).

3.7 Effects of local heterogeneity

It has been already mentioned twice that the interpretation of results from strainmeters is plagued by the distortion of the strainfield of the arriving seismic waves by local heterogeneities. In tidal research this effect is well known to affect amplitudes and phases and in that field the terms: cavity, topographical and geological effects are used. Arrival times and frequencies are not affected, but the local displacement field could differ appreciably from that of a theoretical plane wave even if the approaching wave was plane (see also Wielandt 1993). The scale of these effects is of the order of magnitude of the signal and with purposeful installation one can obtain apparent mechanical amplification up to a factor of 50. Beavan et al. (1979) have shown this with a 1 m-invar wire strainmeter at BFO for earthquakes and tides. Those local effects can be minimized by installing strainmeters far from any local heterogeneities in the long direction, in an area without topography and in/on large homogeneous rock units. However, even with a lot of care these effects cannot be avoided completely. The ground around the instrument and its heterogeneities must be considered a part of the instrument (largely unknown) if amplitudes, phases and waveforms are interpreted and these unknown properties could be a function of time. King et al. (1976) and Sacks et al. (1976) deal with this problem for seismological applications. Beaumont and Berger (1974) suggest using the geological effect on tides for earthquake prediction (see below). For inertial seismometers these effects play a role only at periods much longer than ten seconds, because at higher frequencies the inertial effect (proportional to squared frequency) overwhelms the other contributions to the extent that they are negligible (King et al. 1976). One example, where the locally produced tilts were needed to explain the observations with broadband inertial seismometers was encountered in the near-field of explosions at Stromboli, Italy by Wielandt and Forbriger (1999). Strainseismometers are subject to these effects at all frequencies because they measure in fact differences in the displacement fields. The longer the baseline length L of a strainmeter, the more one can hope that local effects are averaged out, at least small scale effects. Gombert and Agnew (1996) discuss some results from PFO in this context.

4 Some results

The following list is not meant to be comprehensive. It should simply present the spectrum of research possibilities involving strainmeters.

- Strainmeters were successful in recording the Earth's free vibrations and long-period surface waves from the beginning. One famous example is the record of the Isabella, California, quartz-rod strainmeter of the Great Chilean quake 1960 (Ben-Menahem and Singh, 1981, Fig. 5.29). Widmer et al. (1992) and Zürn et al. (2000) show shear

strain spectra from 10 m Invar wire strainmeters at BFO where the fundamental toroidal mode of the Earth, 0T_2 with a period of 44 minutes, stands clearly above the noise floor for the Macquarie 1989 and Balleny Island 1998 events, respectively. The disastrous N-Sumatra–Andaman Islands earthquake on December 26, 2004, excited the seismic free oscillations of the Earth to the largest amplitudes since 1964. Several strainmeters were recording those with unprecedented quality. Park et al. (2008) analyzed spectra from the records of two orthogonal laser extensometers in the Gran Sasso observatory, Italy with very clear observation of the lowest degree fundamental toroidal modes. The strainmeter array at BFO also provided very high quality records. Fig. 4 shows spectra of areal and shear strains computed from the records (Widmer et al. 1992) of three linear strainmeters with the fundamental spheroidal and toroidal modes. The “breathing mode” 0S_0 stands out clearly in the spectrum of areal strain, its initial amplitude was estimated to 8.8×10^{-12} .

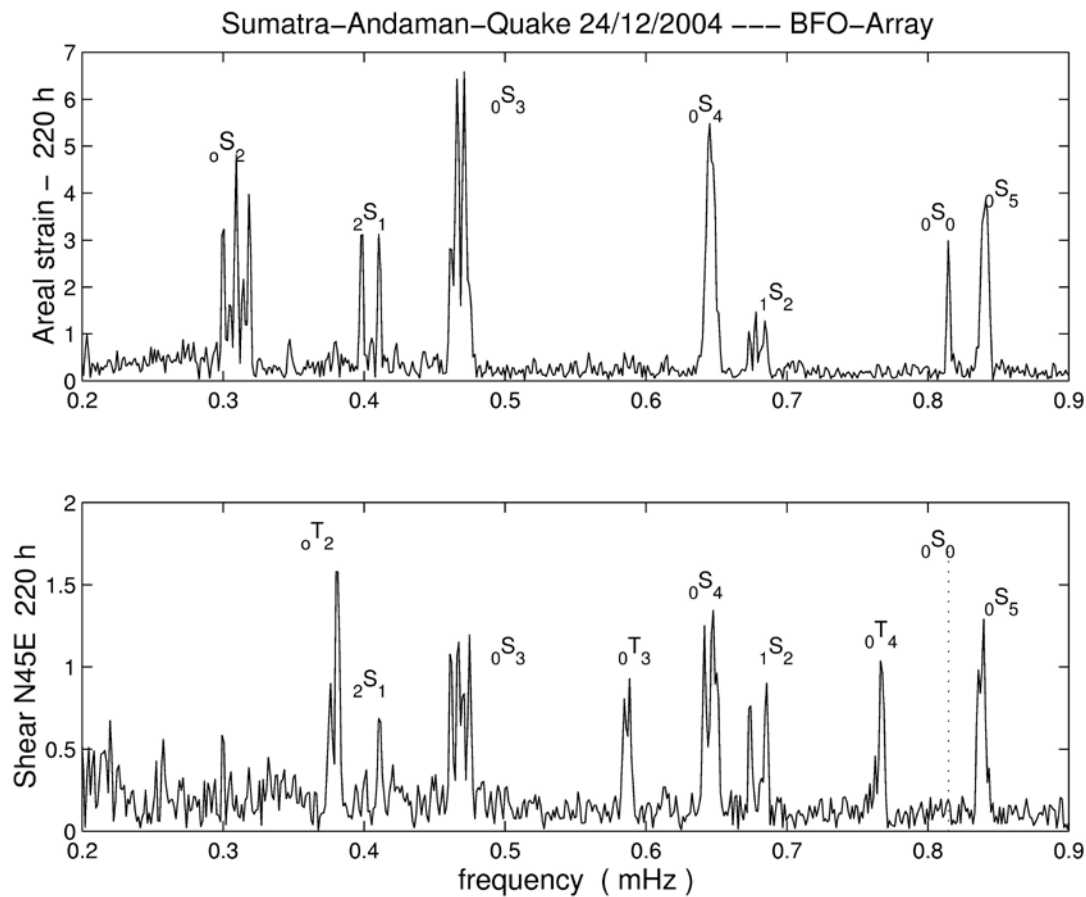

Figure 4 Spectra of areal (top) and shear (bottom) strains calculated from the records of the three linear strainmeters at BFO. Toroidal modes are missing in the areal strain and enhanced with respect to spheroidal modes in the shear strains. Many of the multiplets show splitting due to symmetry breaking by rotation and ellipticity. The “breathing mode” 0S_0 is missing in the shear strain, its frequency is indicated by the dotted line. A barometer correction was applied to the linear strain data.

- Coseismic steps consistent with source theory were repeatedly observed with the laser strainmeters at PFO for earthquakes in California (Wyatt, 1988; Agnew and Wyatt, 1989).
- Very clear postseismic strain signals lasting many days were recorded at PFO, California by the laser strainmeters, the borehole tensor strainmeter (Gladwin, 1984) and several tiltmeters (Wyatt et al. 1994) for the 1992 Landers earthquake sequence. The authors conclude that possibly different processes contribute to the observed signals and discuss those.
- Linde et al. (1993) were able to derive a detailed picture of the mechanism of an eruption of Hekla volcano, Iceland from the records of several Sacks-Evertson borehole dilatometers installed between 14 and 45 km away from the summit.
- Slow and silent earthquakes have repeatedly been reported from records by borehole dilatometers in California and Japan (e. g. Linde et al. 1996).
- Earth tides are continuously probing the Earth with periods of 12 and 24 hours. They can be used to study the response of the rocks. Agnew (1981) tried to find out about nonlinear behaviour of the rocks using data from the laser strainmeters at PFO. He concludes, that in the absence of evidence for nonlinearity from the tides, seismologists are justified in treating the Earth as a linear system. This kind of study is limited by the strain effects of nonlinear ocean tides.
- Beaumont and Berger (1974) suggested from experiments with Finite-Element models, that the earthquake preparation process should modify rock properties near the fault (i.e., by dilatancy) and thus the amplitudes of the tidal strains observed near the fault. Several groups made attempts to make such observations with no success up to date: Linde et al. (1992) looked at borehole dilatometer and tensor strainmeter records in the vicinity of the Loma Prieta, California, quake in 1992 and Omura et al. (2001) investigated super-invar bar-strainmeter data around the 1995 Kobe earthquake from a mine at a distance of 25 km from the epicenter (see also Westerhaus and Zschau, 2001, for a short summary of other attempts) . Latynina and Rizaeva (1976) report tidal strain amplitude variations observed with quartz rod strainmeters before an earthquake, but are not certain about the significance of this result.
- Secular crustal deformation rates have been always a major observation goal for strainmeters. Basically they are able to see this signal, but because of the high and non-stationary noise at ultra-low frequencies, the interpretation in this spectral band is extremely difficult. The work with the very long laser strainmeters at Pinion Flat (PFO), in combination with other instruments and methods, is the most careful one (see articles by Agnew, Wyatt and colleagues) ever performed in this direction. PFO is located between the San Andreas and San Jacinto faults in Southern California and only 10 to 15 km away from both.

5 Strain- vs. inertial seismometers

In practice inertial seismometers by far outnumber strainmeters. It is also a fact that experimental seismological research is based mainly on the records from inertial seismometers with very few contributions from the few strainmeters. More than 100 borehole tensor strainmeters (type: Gladwin, 1984) and long-baseline laser strainmeters will be installed (starting 2004) at the Plate Boundary Observatory in the Western United States in order to detect strain signals close to the active faults. Although this presents a large boost in the total number of strainmeters it will not yet change the general imbalance in the use of strainmeters as compared to inertial seismometers.

There are several reasons for this imbalance:

- Inertial seismometers, short-period and broadband, are commercially available, while highly sensitive strainmeters are not. The costs to produce a competitive laser strainmeter are very high, but a Cambridge type wire strainmeter can be produced very cheaply, compared to the cost of a modern broadband seismometer.
- Short-period and most broadband seismometers are very easy to set up. STS-1 seismometers need more care if highest quality is requested. Strainseismometers require much more work for their installation. Borehole seismometer and borehole strainmeter installation probably is comparable.
- By far the most seismological routine work, especially at the regional scale with local networks, is performed analyzing body waves with periods of a few seconds to frequencies of several tens of Hz. At these frequencies most strainmeters, due to their relatively large dimension, suffer from parasitic resonances of some kind depending on the individual design. Possible exceptions are the Sacks-Evertson dilatometer and the borehole tensor strainmeters because they are more compact.
- Strainmeters, in contrast to short-period seismometers, are extremely noisy if installed near the surface of the Earth due to environmental variations of temperature and air pressure and their effects on the instrument itself and the ground around it. Therefore high quality can only be obtained in boreholes, mines and tunnels or by anchoring them to points at depth. This leads to added installation costs, especially if boreholes have to be drilled for the installation. Basically the cost of the borehole has to be added to the cost of the instrument.

It is noted here that the users of global digital broadband data know the differences in quality between vertical and horizontal components as a function of the depth of installation. At long periods the horizontals are very sensitive to tilts (see 5.3.3). Both tilt and strain are local spatial derivatives of the displacement field and show similar local effects in terms of noise and distortions. Therefore the fairest comparison for strainmeters would be to the long-period horizontal inertial seismometers.

For a given input wave amplitude, the amplitude of the output signal is proportional to $1/\lambda = f/c$ for a strainmeter and $\sim f^2$ for an inertial seismometer (with λ - wavelength, f - frequency, c - phase velocity). Accordingly, when considering waves with equal c , strainmeters have more and more advantage the lower the frequency gets (for both types of sensors the noise power (see Figure 2) rises strongly with decreasing frequency). Most of the research cited above belongs to "zero-frequency seismology". Low-frequency research work makes sense especially in the near-fields of earthquake faults and active volcanoes (creep events, slow and

silent earthquakes, pre-, co- and postseismic strain transients, de- and inflation periods, etc.) . However, it is prudent not to rely on a single instrument because noise at very long periods is non-stationary and any changes in the coupling of the instrument to the ground or in the materials of the instrument itself will appear as a signal.

References

- Agnew, D. C. (1981). Nonlinearity in rock: evidence from Earth tides. *J. Geophys. Res.*, **86**, B5, 3969 - 3978.
- Agnew, D. C. (1986). Strainmeters and tiltmeters. *Rev. Geophys.*, **24**, 579 - 624.
- Agnew, D. C., Wyatt, F. K. (1989). The 1987 superstition hills earthquake sequence: strains and tilts at Pinion Flat Observatory. *Bull. Seism. Soc. Am.*, **79**, **2**, 480 - 492.
- Beaumont, C., and Berger, J. (1974). Earthquake prediction: modification of Earth tide tilts and strains by dilatancy. *Geophys. J.R. astr. Soc.*, **39**, 111 - 118.
- Beavan, J., Bilham, R., Emter, D., King, G. C. P. (1979). Observation of strain enhancement across a fissure. *Dt. Geod. Komm., Reihe B*, **231**, 47 - 58.
- Ben-Menahem, A., and Singh, S. J. (1981). Seismic waves and sources. *Springer-Verlag*, New York, Heidelberg, Berlin, 1108 pp.
- Evans, K., and Wyatt, F. (1984). Water table effects on the measurement of Earth strain. *Tectonophysics*, **108**, 323 - 337
- Fix, J. E., and Sherwin, J. R. (1970). A high-sensitivity strain-inertial seismograph installation. *Bull. Seism. Soc. Am.*, **60**, 1803 - 1822.
- Gladwin, M. T. (1984). High precision multi-component borehole deformation monitoring. *Rev. Sci. Instrum.*, **55**, 2011 - 2016.
- Gomberg, J., and Agnew, D. C. (1996). The Accuracy of Seismic Estimates of Dynamic Strains: An Evaluation Using Strainmeter and Seismometer Data from Pinion Flat Observatory, California. *Bull. Seism. Soc. Am.*, **86**, 212 - 220.
- Gouly, N. R., King, G. C. P., and Wallard, A. J. (1974). Iodine stabilized laser strainmeter. *Geophys. J. R. astr. Soc.*, **39**, 269 - 282.
- King, G. C. P, and Bilham, R. G. (1976). A geophysical wire strainmeter. *Bull. Seism. Soc. Am.*, **66**, 2039-2047.
- King, G. C. P., Zürn, W., Evans, R., and Emter, D. (1976). Site corrections for long period seismometers, tiltmeters and strainmeters. *Geophys. J. R. astr. Soc.*, **44**, 405 - 411.
- Kümpel, H.-J. (1992). About the potential of wells to reflect stress variations within the inhomogeneous crust. *Tectonophysics*, **211**, 317 - 336.
- Latynina, L. A., and Rizaeva, S. D. (1976). On tidal-strain variations before earthquakes. *Tectonophysics*, **31**, 121 - 127.
- Levine, J., and Hall, J. L. (1972). Design and operation of a methane absorption stabilized laser strainmeter. *J. Geophys. Res.*, **77**, 2595 - 2609.
- Linde, A. T., Gladwin, M. T., and Johnston, M. J. S. (1992). The Loma Prieta Earthquake, 1989 and the Earth strain tidal amplitudes: an unsuccessful search for associated changes. *Geophys. Res. Lett.*, **19**, 317 - 320.
- Linde, A. T., Agustsson, K., Sacks, I. S., and Stefansson, R. (1993). Mechanism of the 1991 eruption of Hekla from continuous borehole strain monitoring. *Nature*, **365**, 737-740.

- Linde, A. T., Gladwin, M., Johnston, M. J. S., Gwyther, R. L., and Bilham, R. (1996). A slow earthquake sequence on the San Andreas fault. *Nature*, **383**, 65 - 68.
- Lomnitz, C. (1997). Frequency response of a strainmeter. *Bull. Seism. Soc. Am.*, **87**, 1078 - 1080.
- Mikumo, T., and Aki, K. (1964). Determination of local phase velocity by intercomparison of seismograms from strain and pendulum instruments. *J. Geophys. Res.*, **69**, 721-731.
- Milne, J. (1888). The relative motion of neighbouring points of ground. *Trans. Seism. Soc. Jap.*, **12**, 63 - 66.
- Omura, M., Otsuka, S., Fujimori, K., and Yamamoto, T. (2001). Tidal strains observed at a station crossing the Otsuki Fault, Kobe, Japan, before the 1995 Hyogoken-Nanbu earthquake. *J. Geodetic Soc. Japan*, **47**, 441 - 447.
- Park, J., Amoroso, A., Crescentini, L., and Boschi, E. (2008). Long-period toroidal earth free oscillations from the great Sumatra-Andaman earthquake observed by paired laser extensometers in Gran Sasso, Italy. *Geophys. J. Int.* **173**, 887-905.
- Sacks, I. S., Suyehiro, S., Evertson, D. W., and Yamagishi, Y. (1971). Sacks-Evertson strainmeter, its installation in Japan and some preliminary results concerning strain steps. *Papers in meteorology and geophysics*, **22**, 195 - 208.
- Sacks, I. S., Snoke, J. A., Evans, R., King, G., and Beavan, J. (1976). Single-site phase velocity measurement. *Geophys. J. R. astr. Soc.*, **46**, 253 - 258.
- Westerhaus, M., and Zschau, J. (2001). No clear evidence for temporal variations of tidal tilt prior to the 1999 Izmit and Düzce earthquakes in NW-Anatolia. *J. Geodetic Soc. Japan*, **47**, 448 - 455.
- Wielandt, E. (1993). Propagation and structural interpretation of non-plane waves. *Geophys. J. Int.*, **113**, 45 - 53.
- Wielandt, E., and Forbriger, T. (1999). Near-field seismic displacement and tilt associated with the explosive activity at Stromboli. *Annali Geofisica*, **42**, 407 - 416.
- Widmer, R., Zürn, W., and Masters, G. (1992). Observation of low-order toroidal modes from the 1989 Macquarie Rise event. *Geophys. J. Int.*, **111**, 226 - 236.
- Wyatt, F. (1988). Measurements of coseismic deformation in Southern California. *J. Geophys. Res.*, **93**, 7923 - 7942.
- Wyatt, F., Beckstrom, K., and Berger, J. (1982). The optical anchor - a geophysical strainmeter. *Bull. Seism. Soc. Am.*, **72**, 1707 - 1716.
- Wyatt, F., Agnew, D. C., and Gladwin, M. (1994). Continuous measurements of crustal deformation for the 1992 Landers Earthquake Sequence. *Bull. Seism. Soc. Am.*, **84**, 768 - 779.
- Zadro, M., and Braitenberg, C. (1999). Measurements and interpretations of tilt-strain gauges in seismically active areas. *Earth Science Reviews*, **47**, 151 - 187.
- Zürn, W., Laske, G., Widmer-Schmidrig, R., and Gilbert, F. (2000). Observation of Coriolis coupled modes below 1 mHz. *Geophys. J. Int.*, **143**, 113 - 118.