

Simultaneous determination of Ne, Ar, SF₆, CFC-11 and CFC-12 in groundwater by gas chromatography

P. Mochalski, I. Sliwka, and J. Lasa

Institute of Nuclear Physics PAN Radzikowskiego 152 street, PL-31342 Krakow, Poland

Introduction

Sulphur hexafluoride (SF₆) and Freons become commonly used for dating young groundwaters whereas noble gases mainly serve for determining the temperature of recharge and the air excess which is also needed to correct measured values of SF₆ concentrations [1-3]. Usually, determination of Ne, Ar, SF₆, CFC-11 and CFC-12 requires two or three independent instrumental analyses and separate sets of samples [1, 2]. Within this work, an analytical method for simultaneous determination of all five tracers in a single sample of water is presented.

Sampling

Water samples are taken in duplicate through copper tubes into specially constructed 2.9-L stainless steel vessels. Before sampling containers are carefully flushed with high-purity nitrogen to remove air. Wells are sampled under pressure to avoid sample degassing. Contamination by air is controlled by measurements of dissolved oxygen. Samples are stored in a laboratory refrigerator at 6 °C. An effort is made to analyse them within 2 days after sampling.

Analytical method

Sample vessels are also used as measuring vessels by heads-space extraction technique (HS) [4] and gas chromatography (GC). The scheme of analytical system is shown in Fig 1.

The headspace volume is created in the sample vessel using high-purity nitrogen (99.9999%) and a syringe (S). The vessel is shaken mechanically for 20 minutes to obtain equilibrium between the gas and

liquid phase. Next, the equilibrated gas is transferred into the vacuum extraction and purification line (thickened lines in Fig 1). Dried in Nafion tube extracted HS gas fills in two sample loops (P2 and P3) and a glass 125 ml-in-volume pipette.

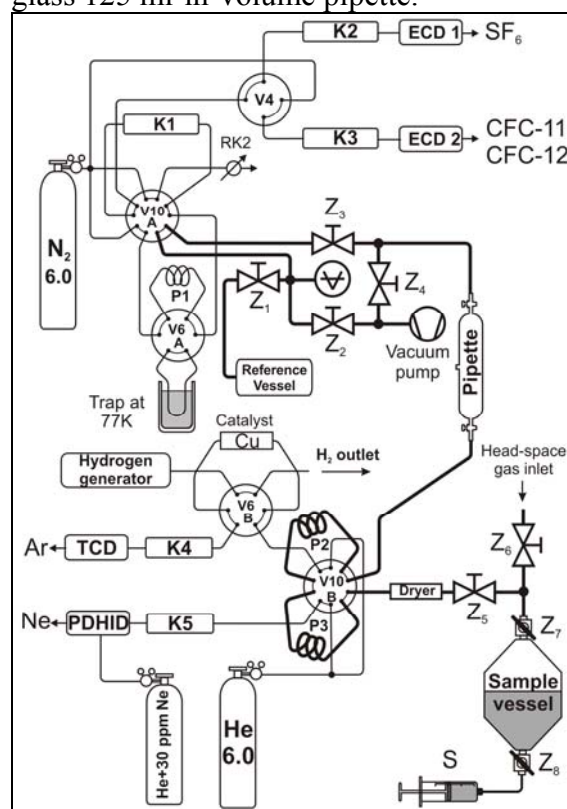

Fig 1 Scheme of measurement system.
Z₁₋₆ – Nupro valves

Neon is measured with a GC-PDHID. Carrier gas (He 6.0) transports extracted HS gas from the P3 loop (2ml) into a 30m×0.56 capillary column filled with molecular sieve 5A. Neon is detected by Valco PD-D2 detector doped with Ne (30 ppm of Ne in discharge helium) [5, 6]. Argon is analysed with a TCD detector. A 0.5 ml of gas sample (loop P2) is separated in a 1.5 m×1/8 inch packed column (K4) filled with molecular sieve 5A. Separation

of Ar and O₂ is achieved via a catalytic removal of oxygen from the sample at elevated temperature (grains of Cu at 200°C) [6]. The catalyst is periodically activated using hydrogen.

SF₆ and CFCs are measured using three chromatographic columns operating in a back-flush mode, and two electron capture detectors (ECD) [7]. The extracted HS gas filling the glass pipette (125 ml) is cryofocused (77 K) under lowered pressure on a trap packed with glass pellets. After desorption gases are injected into a 2 m×1/8" column (K1) filled with n-octan on Porasil C. This column is connected for particular time intervals to a 3 m×1/4" column (K2) packed with 5Å molecular sieve and next to a 0.5 m×1/8" column (K3) filled with n-octan on Porasil C. Column K1 works in a back-flush mode. SF₆ is detected in the ECD1 detector, whereas CFCs in the ECD2. The measurements are calibrated against standards obtained from Linde gas (Ne and Ar) and from the Scripps Institution of Oceanography, San Diego, USA (SF₆ and CFCs).

Typical chromatograms of a water sample are presented in Fig. 2.

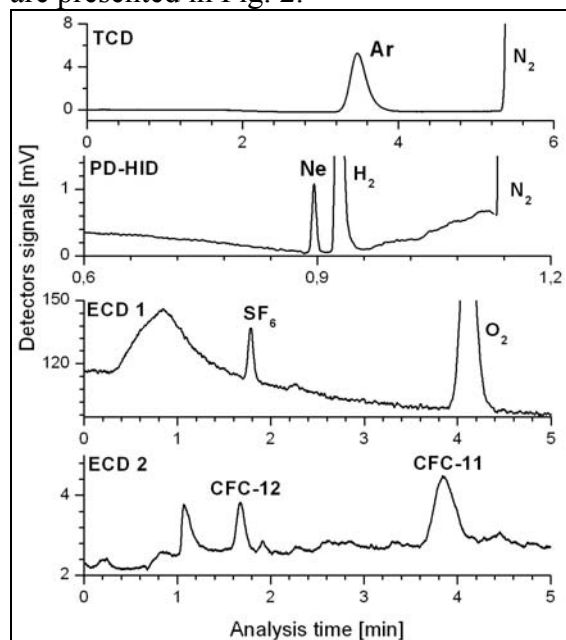

Fig 2 An example of chromatograms from groundwater analysis

The total analysis time is 50 minutes, including extraction and cryofocusing. Detection limits for measured tracers are 0.06

fmol/L (0.0081 pg/kg) for SF₆, 15 fmol/L (2.1 pg/kg) for CFC-11, 10 fmol/L (1.23 pg/kg) for CFC-12, 0.84 nmol/L (1.9×10^{-8} cm³_{STP}/cm³) for Ne and 0.15 μmol/L (3.1×10^{-6} cm³_{STP}/cm³) for Ar. The reproducibility estimated for modern water sample is 1.6% for Ne, 0.8% for Ar and 5% for SF₆ and CFCs.

Conclusions

Simultaneous measurement of Ne, Ar, SF₆, CFC-11 and CFC-12 in groundwater has numerous advantages. The number of samples needed to obtain all tracers data as well as sampling time is significantly reduced. Relatively inexpensive gas chromatographic technique reduces analysis cost and laboratory effort.

Acknowledgments

This work was financially supported by the Polish Committee for Scientific Research (grants 4T12B.004.28 and 3.T09D.038.29 in the time period of 2006-2008).

References

- [1] M. Gröning, L.F. Han, P. Aggarwal, Use of chlorofluorocarbons in hydrology a guidebook, Vienna, International Atomic Energy Agency, 2006,
- [2] D. Porcelli, C.J. Ballentine, R. Wieler, Noble gases in geochemistry and cosmochemistry, The Mineralogical Society of America, Washington, 2002.
- [3] A. Zuber, S. Wiczak, K. Rozanski, I. Sliwka, M. Opoka, P. Mochalski, T. Kuc, J. Karlikowska, J. Kania, M. Jackowicz-Korczynski, M. Dulinski, Hydrol. Process., 19 (2005), 2247
- [4] I. Sliwka, J. Lasa. Chem. Anal. (Warsaw), 45 (2000), p. 59.
- [5] J. Lasa, P. Mochalski, J. Pusz. J. Chromatogr. A, 1035 (2004), p. 261.
- [6] P. Mochalski, J. Lasa, I. Sliwka, Chem. Anal. (Warsaw), 51 (2006), p. 825.
- [7] I. Sliwka, J. Lasa, A. Zuber, M. Opoka, M. Jackowicz-Korczynski, Chem. Anal. 49 (2004), p. 535.