

Michael Naumann

**High Pressure-High
Temperature-Apparatus
(HPTM - Paterson Type)**

Maintenance / Service

(04/2024)

Scientific Technical Report STR24/02

Recommended citation of the publication

Naumann, M. (2024): High Pressure-High Temperature-Apparatus (HPTM - Paterson Type): Maintenance / Service; (04/2024), (Scientific Technical Report STR; 24/02), Potsdam: GFZ German Research Centre for Geosciences.
<https://doi.org/10.48440/gfz.b103-24021>

Imprint

Helmholtz Centre Potsdam
GFZ German Research Centre for Geosciences
Telegrafenberg
D-14473 Potsdam

Published in Potsdam, Germany
2024

DOI: <https://doi.org/10.48440/gfz.b103-24021>
URN: urn:nbn:de:kobv:b103-24021

This work is published in the GFZ series Scientific Technical Report STR and electronically available via our repository GFZpublic: <https://tinyurl.com/GFZ-ST-Reports>



This work is licensed under a Creative Commons Attribution 4.0 International License.
(CC BY 4.0) <https://creativecommons.org/licenses/by/4.0/>

High Pressure-High Temperature-Apparatus (HPTM - Paterson Type)

Michael Naumann

Maintenance / Service

(04/2024)

The Paterson Machine

Part A: Purpose and Capability of the Paterson Apparatus

1. Intro
2. Brief History of HP-HT Deformation Machines
3. General Specifications and Characteristics of the Machine
4. Types of Experiments typically performed with the Machine

Part B: Engineering Aspects

1. Modules
 - 1.1. Default Modules
 - 1.2. Acoustic Module
2. Technical Specifications
3. Documentation and Drawings

Part C: Documentation “How to ...”

1. General Introduction to the Machine
2. Sample Preparation
3. Jacket - Materials and Preparation
4. Preparation and set-up of an Experiment
5. Running an Experiment
 - 5.1. Deformation and Torsion Experiment (Default)
 - 5.2. Deformation and Torsion Experiment (with Acoustic System)
6. Sample Recovery

7. Calibration
 - 7.1. Furnace Calibration
 - 7.2. Axial Displacement Calibration (external DCDT)
 - 7.2.1. Initial Pre-Calibration of the DCDT
 - 7.2.2. Calibration of the DCDT
 - 7.3. Load Cell Calibration (→ Appendix A)
 - 7.3.1. Theory
 - 7.3.2. Calibration Procedure
 - 7.3.3. ILC - Calibration-Check
 - 7.4. Twist Calibration
 - 7.4.1. Initial Pre-Calibration of the RVDT
 - 7.4.2. Calibration of the RVDT
 - 7.5. Torque Cell Calibration (→ Appendix B)
 - 7.5.1. Theory
 - 7.5.2. Calibration Procedure
 - 7.5.3. ITC – Calibration-Check
 - 7.6. Axial Stiffness Calibration

- 7.7. Axial Jacket Correction
- 7.8. Torsion Stiffness Calibration
- 7.9. Torsion Jacket Correction

8. Furnace

- 8.1. Specifications
- 8.2. How to build a Furnace
 - 8.2.1. How to put windings on the furnace tube – segmented design
 - 8.2.2. How to put windings on the furnace tube – monobloc design
 - 8.2.3. How to assemble a furnace – segmented design
 - 8.2.4. How to assemble a furnace – monobloc design
 - 8.2.4.1. Assemble of the outer furnace part
 - 8.2.4.2. Assemble of the inner furnace part
 - 8.2.4.3. Completion of the whole furnace

9. Service and Maintenance

- 9.1. Change of O-Rings - Furnace-Feed-Throughs
 - 9.1.1. Removal of the Furnace
 - 9.1.2. Disassemble the Furnace
 - 9.1.3. Change of O-Rings
 - 9.1.4. Reinstallation of the Furnace
- 9.2. Change of O-Rings - Bottom Plug and ILC
 - 9.2.1. Removal of the Bottom Plug
 - 9.2.2. Change of O-Rings at the Bottom Plug
 - 9.2.3. Change of O-Rings inside ILC
 - 9.2.3.1. Open top of the ILC
 - 9.2.3.2. Removal of the internal blank block
 - 9.2.3.3. Removal of the internal LVDT-Block (LVDT & Feed-Throughs)
 - 9.2.3.4. Removal of the internal US-Block (Sensor & Feed-Through)
 - 9.2.3.5. Disassemble and reassemble ILC
 - 9.2.4. Change of O-Rings of the Feed-Throughs
 - 9.2.4.1. Internal LVDT-Block
 - 9.2.4.2. Internal US-Block
 - 9.2.5. Reinstallation of the Bottom Plug
- 9.3. Change of O-Rings – Pressure Vessel
- 9.4. Change of O-Rings – Intensifier
 - 9.4.1. Change of the Gas O-Ring
 - 9.4.2. Change of the Oil O-Ring
- 9.5. Change of O-Rings – Volumometer

Part D: Further technical Developments at GFZ Potsdam

- 1. Furnace – monobloc-design
- 2. US-Measurement in creep, deformation & torsion experiments
 - 2.1. US-Sensor at the bottom in the internal load cell
 - 2.2. US-Sensor at the bottom in the specimen bottom plug
 - 2.3. US-Sensor in specimen top plug – one single ring
 - 2.4. US-Sensor in specimen top plug – two concentric rings

- 2.5. US-Sensor in specimen top plug – two half rings
3. Internal load cell with ball bearing (< 54 kN) – isolate torque and axial load
4. Internal load cell – different deformation bodies for torque and axial load

Appendices

- A Kalibrierung ILC
- B Deformation Kammer & Solid Body
- C Kalibrierung ITC

Part A: Purpose and Capability of the Paterson Apparatus

1. Intro

This manual intends to describe the capability, handling and maintenance of the Paterson gas rig in detail from the prospective of users that performed numerous experiments and gained lots of experience since the 1960's. Its purpose is not to replace the instruction manuals supplied with the various machines delivered around the world, but to enable new (and experienced) users to carry out deformation experiments and solve problems that may arise during daily use. Since currently many existing apparatuses are not in use and the remaining 'hands-on' operators are going to retirement at some point, we think that it is important to collect, bundle and pass on the knowledge that we gained over the time using this impressive and easy-to-use machine, which still is the state of the art deformation apparatus for performing high temperature, high pressure experiments on rocks under conditions of the Earth's crust and uppermost mantle.

This manual refers in some detailed parts of the descriptions to the two machines currently installed (2024) at **GFZ Potsdam** with **Eurotherm** controllers (type 2604) for the different actuators. For the data acquisition the hard- and software of **Delphin Technology**, for the later corrections and calculations the software **Origin** from **Origin Lab** are used. At other machines in other labs some details may be different.

2. Brief History of the HP-HT Deformation Machines

The HP-HT Deformation Machine was invented in the 1960's and was designed to measure and understand the strength and deformation processes in earth materials at conditions equivalent to those deep in the Earth's crust and underlying mantle, where temperatures can be as high as 1,000°C.

Built largely in-house at Australian National University (ANU) by technical staff and overseen by geophysicist, Emeritus Professor Mervyn Paterson, the 'Paterson apparatus' still provides mechanically precise readings for rock experiments conducted under high pressures and temperatures.

A demand for similar high-pressure, high-temperature rock deformation apparatus overseas led to Professor Paterson designing a commercial version in the 1980s. As a result, 12 machines were sold to labs in the UK, France, Germany, Switzerland, the US and China. More recently, Emeritus Professor Paterson has made his designs freely available to be archived and used in institutions in Europe and the USA.

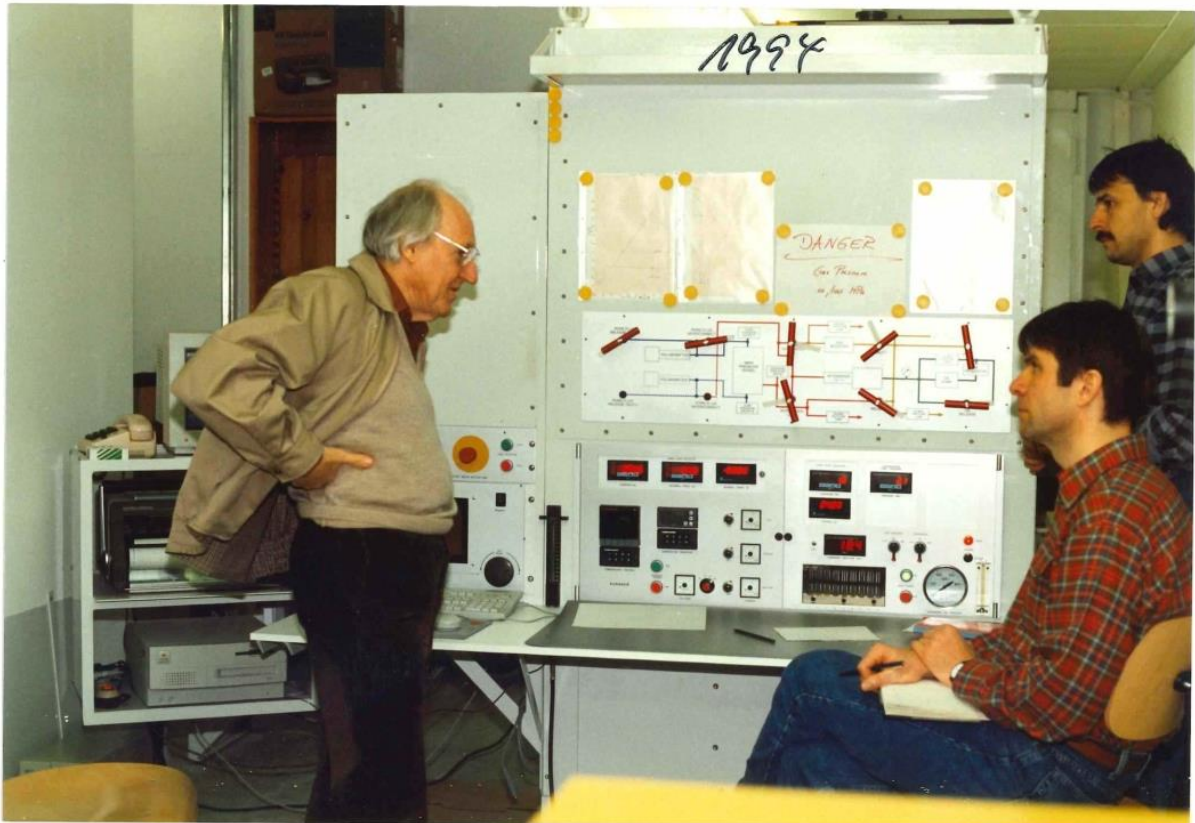

3. General Specifications and Characteristics of the Machine

- ➔ **DESCRIPTION OF PATERSON HIGH-PRESSURE HIGH-TEMPERATURE (HPT) TESTING SYSTEM** ©Australian Scientific Instruments Pty Ltd, 2006, HPT Description
- ➔ <https://cord.mit.edu/resources/paterson-rig-mit>

The HP-HT deformation machine provides an environment of confining pressure to 500 MPa and temperature to 1300 °C in argon gas for experimental purposes.

This apparatus is uniquely suited for high-resolution deformation experiments of relatively large samples up to 15 mm in diameter and 30 mm in length thanks to its internal load cell and compensated piston design, which eliminates any seal friction from load measurements. The apparatus has a three-zone furnace with temperature gradients of <math><1\text{ }^\circ\text{C}/\text{mm}</math> and a hot-zone ~40 mm in length. Furthermore, it is equipped with a pore pressure system that allows for permeability measurements during deformation as well as introduction of various fluids into the deforming rocks at high pressures and temperatures.

There is an ongoing further development of this machine at GFZ and different other labs. Recently, one of the machines in Potsdam has been upgraded to allow acoustic velocity and acoustic emission (AE) measurements in deformation experiments, even at high temperatures up to 1200°C.

Another development at GFZ is a change in the design of the internal load cell to improve the cross talk between the axial and torsion signals.

4. Types of Experiments typically performed with the Machine

➔ **DESCRIPTION OF PATERSON HIGH-PRESSURE HIGH-TEMPERATURE (HPT) TESTING SYSTEM** ©Australian Scientific Instruments Pty Ltd, 2006, HPT Description

The main application of the machine is to provide an environment for mechanical testing and associated studies at high pressure and/or high temperature:

- mechanical testing in compression and extension
- mechanical testing in torsion
- experiments involving pore fluids
- measurement of physical properties

Additionally this machine can be used for:

- hot isostatic pressing (HIP)
- materials synthesis
- applications requiring a high-pressure and/or high-temperature environment, such as experimental petrology

Part B: Engineering Aspects

1. Modules

1.1. Default Modules

Axial Deformation Module

Torsion Module

Pore Fluid Module

➔ **DESCRIPTION OF PATERSON HIGH-PRESSURE HIGH-TEMPERATURE (HPT) TESTING SYSTEM** ©Australian Scientific Instruments Pty Ltd, 2006, HPT Description

1.2. Acoustic Module

The 4-channel **acoustic module** consists of

- a pulse generator based on a **cRIO** (National Instruments)
- a high speed high voltage amplifier **WMA-300** (Falco Systems)
- two voltage preamplifiers **Mistras 2/4/6** (Physical Acoustics)
- a control-system (GFZ-design)

The signals of the acoustic sensors are stored in a high speed transient recorder **DaxBoxCF** (Prökel)

2. Technical Specifications

General

Confining pressure 500 MPa

Temperature 1300°C (1600 K)

Axial Deformation Module

Maximum displacement 30 mm

Maximum force 100 kN

Displacement resolution 1 µm

Force resolution 10 N

Axial strain rates (20 mm specimen length) → 10×10^{-2} to 10×10^{-7} [1/s]

Torsion Module

Maximum displacement no limit

Maximum torque 1000 Nm

Displacement resolution 0.001 rad

Torque resolution 0.1 Nm

Shear strain rates (15 mm diameter x 10 mm length) → 10×10^{-3} to 10×10^{-7} [1/s]

Pore Fluid Module

Pore fluid pressure 500 MPa

Maximum volumetric displacement 1900 mm³

Acoustic Module

4 channels (top and bottom of the specimen)

Sensor resonant frequency 2 MHz

Acoustic pulse 150 V (3 μs, stackable)

Sample rate 10 MSamples/s

3. Documentation and Drawings

→ **DESCRIPTION OF PATERSON HIGH-PRESSURE HIGH-TEMPERATURE (HPT) TESTING SYSTEM** ©Australian Scientific Instruments Pty Ltd, 2006, HPT Description

→ <https://openresearch-repository.anu.edu.au/handle/1885/117174>
(link does not work well)

Part C: Documentation “How to ...”

1. General Introduction to the Machine

- ➔ **DESCRIPTION OF PATERSON HIGH-PRESSURE HIGH-TEMPERATURE (HPT) TESTING SYSTEM** ©Australian Scientific Instruments Pty Ltd, 2006, HPT Description
- ➔ **Operator Manual** : “High-Pressure High-Temperature Testing Machine” (GFZ : No.4 & No.7)



2. Sample Preparation

- Samples must be pre-drilled and ground to the final length and diameter
- Samples must have a cylindrical shape, with a maximum tolerance of 0,05 mm of the sample dimensions
- Both faces of the sample must be plane-parallel with a maximum tolerance of 0,01 mm
- Ordinary samples have the diameter and length dimensions of (d x l) of 10 x 20 mm (axial deformation experiment) and 15 x 10 mm (torsion experiment)
- The dimensions of the samples may vary from 7 to 15 mm in diameter and 1 to 30 mm in length, depending on the material and the aim of the experiment
- To fit into the jacket the **real diameter of a sample** has to be slightly smaller than the general value given above
 - o **9,98 (-0,02) mm**
 - o **14,98 (-0,02) mm**
 - o For other diameters similar
- The **length of the sample** may have a tolerance of **+/- 0,1 mm**
- For the “production” of samples “rock-powders” or others may be used
- These powders have to be filled into a metal capsule of appropriate diameter (similar to the sample dimensions) and pressed cold-isostatic in an appropriate tool (and a press)
- Afterwards these capsules have to be pressed hot-isostatic in the Paterson Rig

3. Jacket - Materials and Preparation

- Jacket-material : seamless drawn tube d x s = 15,4...15,5 x 0,15...0,2 [mm]
 - o Steel C10 or C15 (almost pure iron, low content of carbon)
 - o Copper
 - o Nickel
- ➔ The preparation is described in Operator Manual : “Preparing the jacket”

4. Preparation and set-up of an Experiment

- Before installing a piston and/or spacer check those for any breakouts at the edges or other defects at their surfaces
- ➔ Partially described in Operator Manual : “Specimen assembly”

- Set-up of an axial experiment ($D \times L = 10 \times 20 \text{ mm}$)



- Set-up of a torsion experiment ($D \times L = 10 \times 20 \text{ mm}$ or $15 \times 10 \text{ mm}$)



- Set-up of a pore pressure experiment ($D \times L = 10 \times 20 \text{ mm}$)



- Set-up of an acoustic experiment (coaxial sensor at the top) ($D \times L = 10 \times 20 \text{ mm}$)



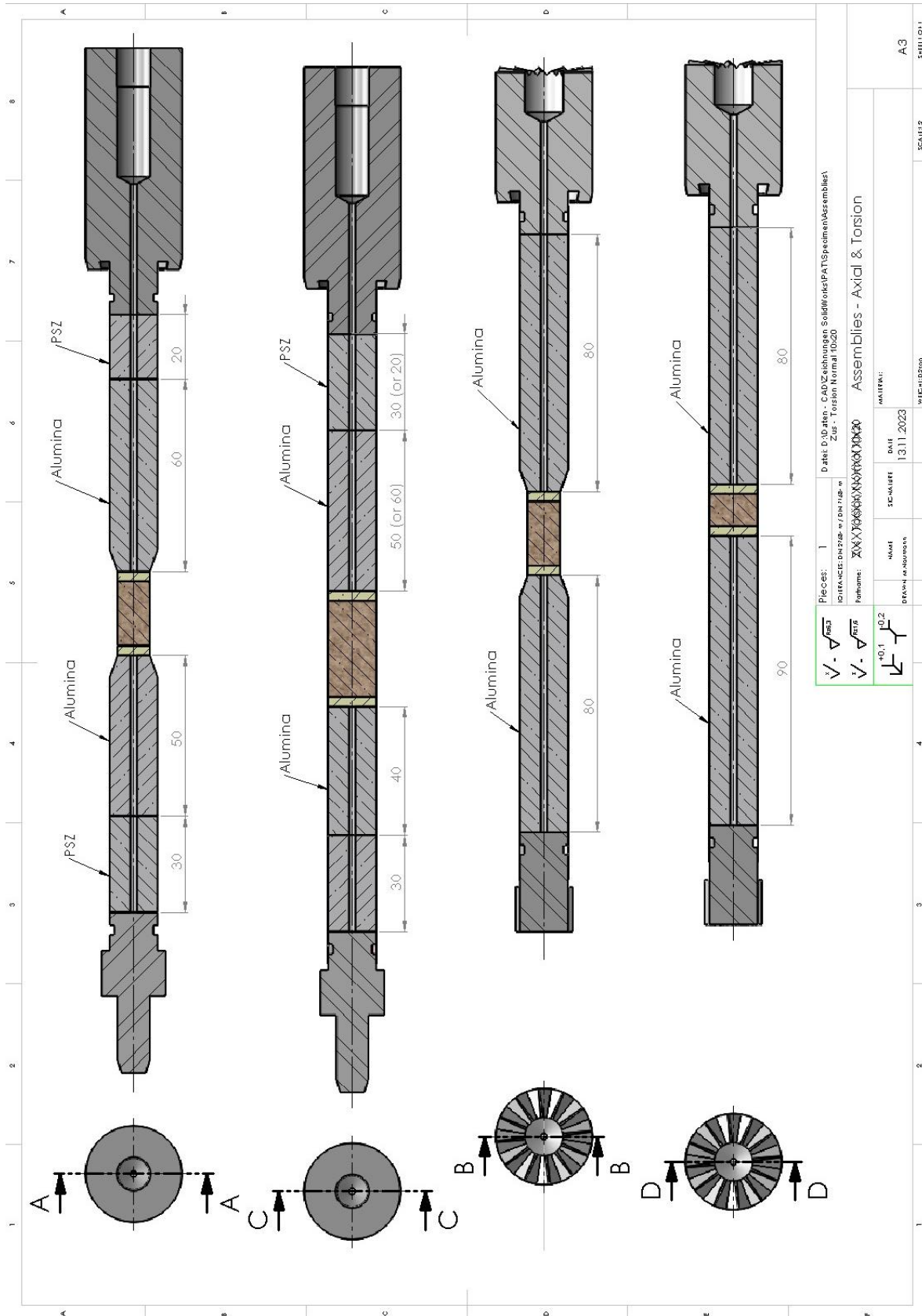

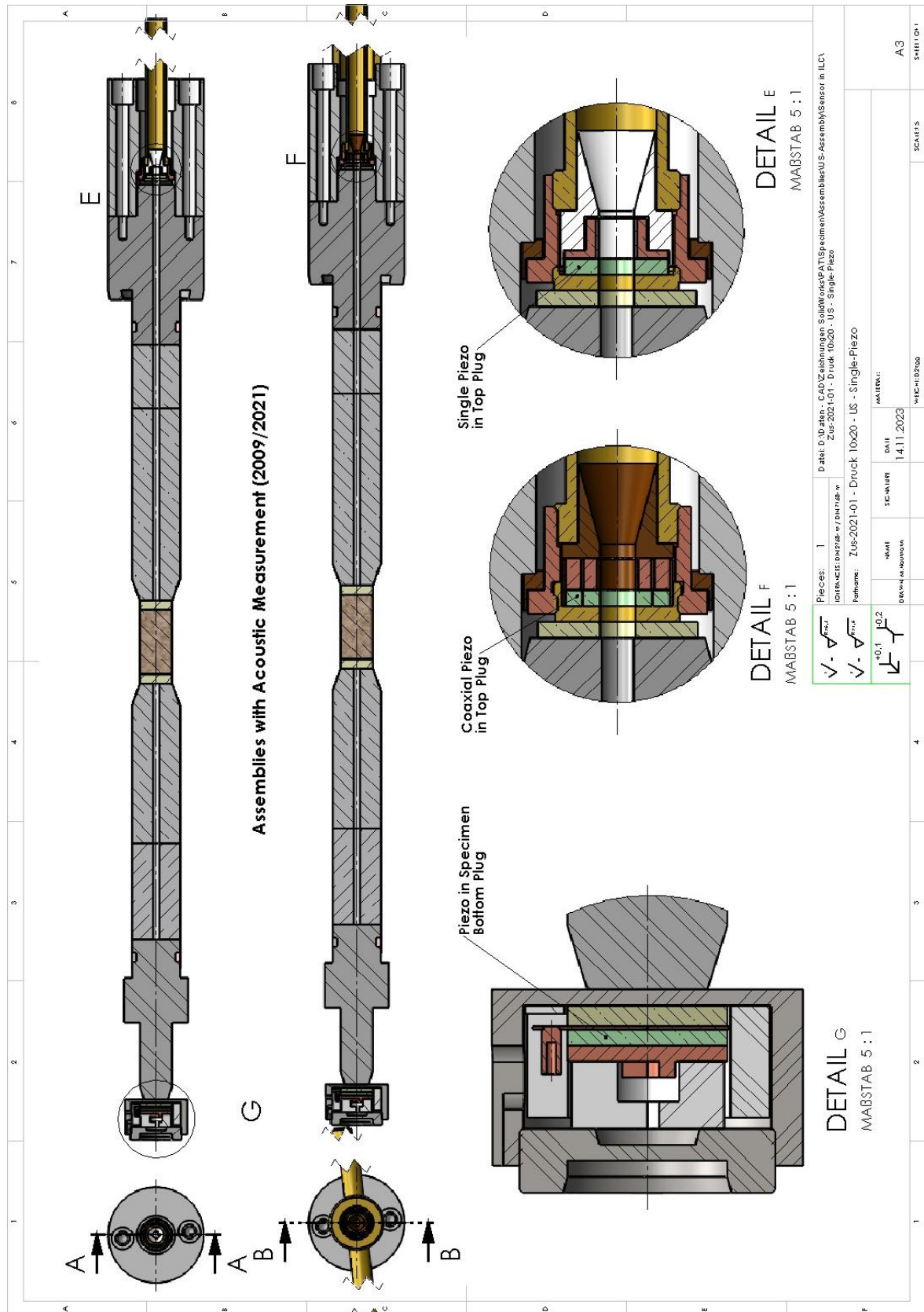

Pieces: 1 Date: D:\03.stern - CAD\Zeichnungen - SolidWorks\PAT\SpeimenAssemblies\US-Assembly\Sensor in ILC1 Zus-2021-01 - Druck 10x20 - US - Single-Piezo	
ID: PAT-001 Konform: Zus-2021-01 - Druck 10x20 - US - Single-Piezo	MATERIAL: DATE: 14.11.2023 SCALE: 5:1 NAME: MABSTAB 5 : 1 DRAWING NUMBER:
10.1 10.2	A3 5:1

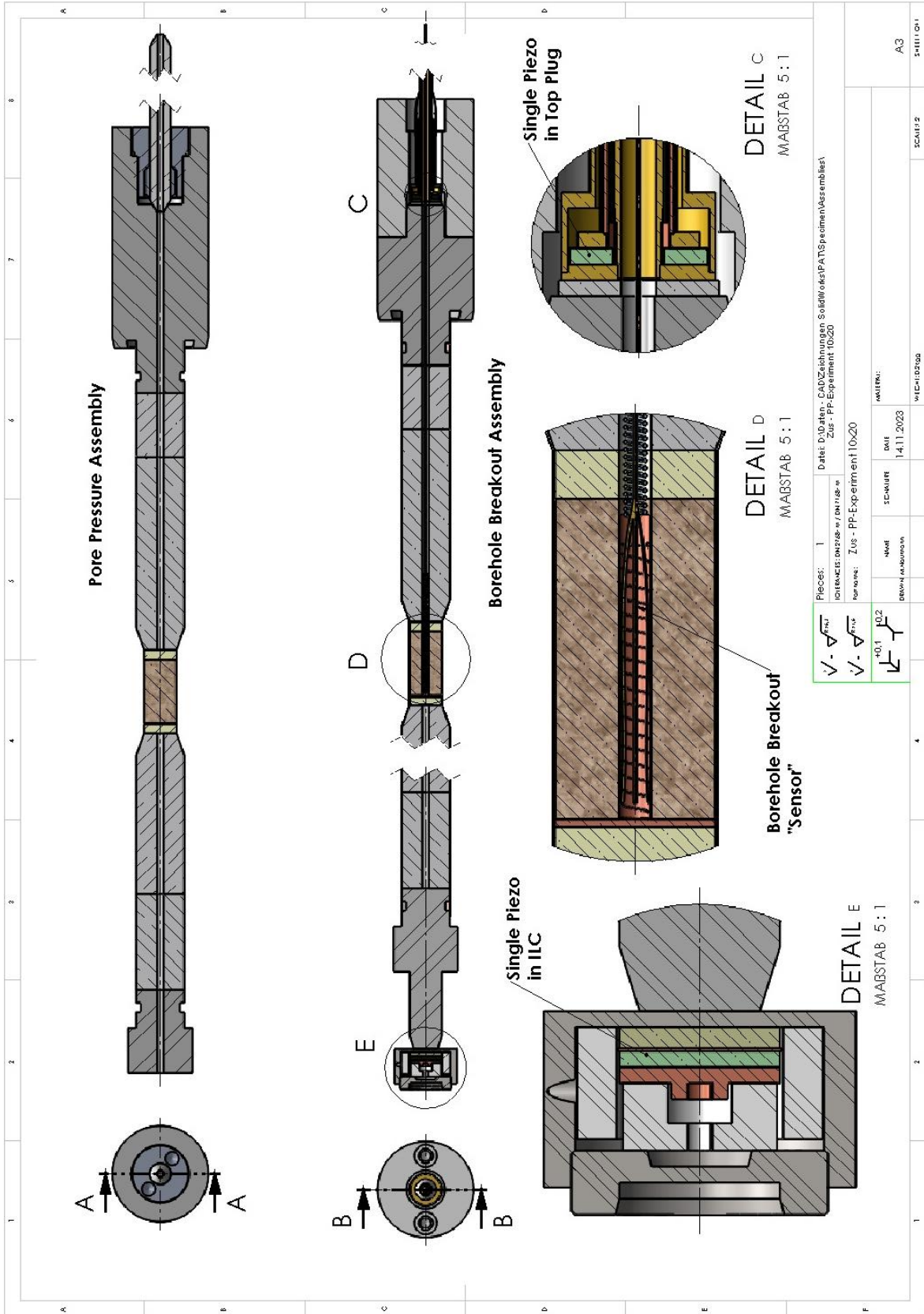

Pieces: 1
 101-TRACE-DIN256-nr / DIN158-nr
 Name: Zus - PP-Experiment10x20
 Datei: D:\3D-Item - CAD-Zeichnungen SolidWorks\PARTS\specimen\Assemblies\Zus - PP-Experiment 10x20

DATEI	14.11.2023
SCHEIBE	
NAME	
DRAWN / ANGEZEIGT	
MATERIAL	
WICHTIGKEIT	
SEITE 12	A3

5. Running an Experiment

5.1. Deformation and Torsion Experiment (Default)

- How to run an experiment depends on the kind of experiment (axial, torsion, pore pressure) and on the different types of controllers, amplifiers etc. installed at the machines, **refer to the Operator Manuals**
- ➔ Axial deformation experiment (described in Operator Manual : “Deformation testing procedure” – No.4: p.16ff; No.7: p.18ff)
- ➔ Torsion experiment (described in Operator Manual : “Torsion testing procedure” – No.7: p.27ff)
- ➔ Pore pressure system (described in Operator Manual : “Experiments with pore pressure fluid” – No.4: p.22ff)

- Setting limits at the different active controllers is important for the safety of the user of the machine as well as to protect the machine itself and the specimen

- At the **pressure controller** there is a pressure limit switch preset for the maximum allowed pressure of 500 MPa, reaching this pressure will open the pneumatic driven release valve of the oil circuit of the intensifier to decrease gas pressure
➔ **never change this presetting**
- At the same controller another limit switch (no. 3) is preset to lock the doors at a gas pressure of 30 MPa, this limit switch will switch off the furnace power as well
➔ this limit switch is very useful to protect the furnace at an accidental rapid pressure loss by setting it to a higher value of about 50% of the gas pressure of an experiment
- There are two more limit switches. No.1 is used to switch off the intensifier at the set experimental pressure. No.2 defines the pressure tolerance (absolute value) at which the pneumatic driven release valve of the oil circuit of the intensifier will start decreasing gas pressure and at which the intensifier will continue to pump at a certain pressure loss respectively
- Additionally there are four **rupture disks** installed at the **confining pressure system**
- The first one protects the pressure vessel and limits the gas pressure to 700 MPa (which is the pressure at which the vessel has been manufactured with autofrettage)
- The second rupture disk protects the gas booster and breaks at 200 MPa (for further increasing the gas pressure with the intensifier the valve between the booster and the intensifier “Intensifier Valve” must be closed!)
- The third rupture disk protects the argon gas bottle and limits the pressure to 30 MPa, if the release valve is open already but the dump valve still closed
- The fourth rupture disk protects the oil pump at the intensifier and breaks at 80 MPa (the oil flows back to the oil container)

- At the **controller of the axial displacement** (DCDT) there are limits for the minimum and maximum position of the axial actuator, these limits stop the axial actuator without interrupting the power of the motor
 - this means, if the measured displacement signal returns to a value in between the two limits (for any reason), the axial actuator continues to move
- The **lower limit** is important to avoid moving down (out of the vessel) the pistons of the bottom plug too far and to damage the internal load cell by rupturing its stem
 - **never set a value smaller/lower than 5 mm**
- The **upper limit** serves as a protection for the machine and the sample in any experiment with the axial actuator, especially in a force controlled experiment
 - it needs to be set far enough to the actual measured position to allow sufficient deformation of the sample and near enough to avoid a risky movement of the axial actuator with maximum speed in the case of a broken sample under force control

- At the **controller of the axial force** (ILC) there are limits for the minimum and maximum axial load acting on the sample, these limits stop the axial actuator without interrupting the power of the motor
 - this means, if the measured displacement signal returns to a value in between the two limits (for any reason), the axial actuator continues to move
- The **lower limit** is important in the case of a broken sample in any experiment with the axial actuator, especially in a force controlled experiment
 - it needs to be set near enough to the actual measured axial load to avoid any risky movement of the axial actuator with maximum speed in the case of a broken sample under force control
- The **upper limit** serves as a protection for the machine and the sample in any experiment with the axial actuator
- In the case of an **extension experiment** these limits act exactly the other way around, if the samples breaks

- There are no limits set at the **controller of the twist** (RVDT)

- At the **controller of the torque** (ITC) there are limits for the minimum and maximum torque acting on the sample
- The **lower limit (clockwise)** stops the motor without interrupting the power of the motor and switches off the furnace and the pressure intensifier in any experiment with the torsion actuator, especially in a torque controlled experiment
 - it needs to be set near enough to the actual measured torque to avoid any risky movement of the torsion actuator with maximum speed in the case of a broken sample under torque control as well as to avoid any damage of the furnace in the case of a rapid pressure loss after a sample broke
 - there will be an **alert** at the controller which has to be confirmed and deleted (itools – Eurotherm) before the actuator is able to continue to move
- The **upper limit (counterclockwise)** stops the axial actuator without interrupting the power of the motor and serves as a protection for the machine and the sample in any experiment with the torsion actuator
 - this means, if the measured torque signal returns to a value lower than the upper limit (for any reason), the torsion actuator continues to move

- At the **controller of the position of the volumometer piston** there are limits for the minimum and maximum position of this piston, these limits usually correspond approx. with the end of travel of the piston and stop the volumometer motor without interrupting the power of this motor
→ this means, if the measured position returns to a value in between the two limits (for any reason), the volumometer continues to move
- At the **controller of the pore pressure** there are limits for the minimum and maximum pressure, these limits stop the volumometer motor without interrupting the power of this motor
→ **it is important to set the maximum pore pressure smaller than the confining pressure of the experiment**
→ this means, if the measured pore pressure returns to a value in between the two limits (for any reason), the volumometer continues to move

5.2. Deformation and Torsion Experiment (with Acoustic System)

- How to run an experiment in general depends on the kind of experiment (axial, torsion) and on the different types of controllers, amplifiers etc. installed at the machines, **refer to the Operator Manuals and to section 5.1. (above)**
- To run an experiment with the **acoustic system** refer to the manual of the **DaxBoxCF** and the one of the **cRIO (LabView)** additionally
- **Pore pressure experiments are not possible with the acoustic system**
- In experiments with the acoustic system it is possible to measure the travel time of an acoustic wave through the sample in both directions in certain time intervals and acoustic emissions from the sample additionally
- To ensure time leveling an experiment with the acoustic system (axial or torsion) always has to begin in the following order
 - start the data acquisition of the mechanical data (i.e. **Delphin**)
 - start the data acquisition of the acoustic data (i.e. **DaxBoxCF**)
 - start the pulse generator (i.e. **cRIO**)
 - start the deformation or creep controller (i.e. **Eurotherm**)
- To have a second time leveling at the end of an experiment the following order is recommended
 - stop the pulse generator (i.e. **cRIO**)
 - start the pulse generator (i.e. **cRIO**) for one or two pulses
 - stop the pulse generator (i.e. **cRIO**)
 - stop the data acquisition of the acoustic data (i.e. **DaxBoxCF**)
 - stop the data acquisition of the mechanical data (i.e. **Delphin**)

6. Sample Recovery

- Pull out the top and bottom specimen pistons
- Cut the jacket with a scissors at one end

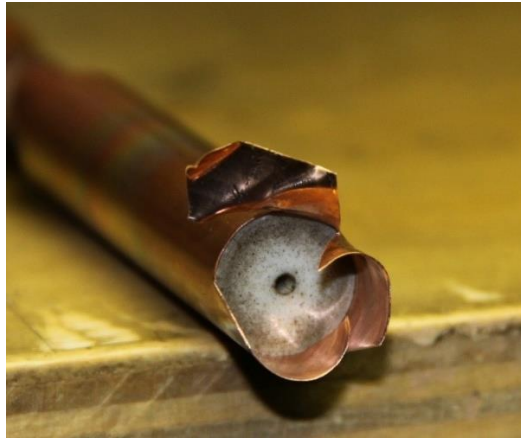

- Peel off the jacket spirally starting from the cut end for getting out the first piston



- Continue peeling off for getting out the first spacer, the specimen, the second spacer and the second piston at least



- **After experiments at temperatures above 1000 °C and the use of two pistons at each side (20...30 mm PSZ and 50...60 mm alumina oxide) it is not possible to peel off the jacket without creating break-outs at the pistons, which make those useless for further experiments**
- In that case the jacket has to be dissolved in acid (aqua regia)

7. Calibration

7.1. Furnace Calibration

- ➔ **Prior to the first (initial) calibration of a new furnace it is recommended to anneal this furnace in the machine at 1250...1300 °C and 300 MPa for at least 24...48 hours**
- ➔ (described in Operator Manual : “Calibration of the furnace”, No.7, p.16...17)
- ➔ **There have been introduced modifications to the High Temperature System, such as a different controller (Eurotherm) and the abandonment of the thermocouple-switch-unit**
- The use of a single-junction thermocouple is sufficient for the calibration as soon as it reaches a position inside the Furnace of about 25...30 mm deeper than the bottom end of the Specimen
- Depending on the actual length of the calibration thermocouple the uppermost position of the traversing arm scale (position 0) corresponds with the deepest position inside the furnace (i.e. 25 mm deeper than the bottom end of the specimen)
- Consequently a certain position of the traversing arm scale with the calibration thermocouple corresponds with the uppermost position of the specimen thermocouple meanwhile an experiment directly above the upper spacer of the specimen, this is the position used for the furnace calibration
- **In contrast to the Operator Manual it was found, that the control of the furnace with the specimen thermocouple is the most satisfactory one**
- It is recommended to start a calibration at moderate temperatures (i.e. 600/700 °C) without using the center winding (no setting at the rheostat)
- The rheostat-setting of the top winding may be of about 70% at the beginning
- Depending on the temperature profile over the hot zone (specimen) the setting of the top winding should be adjusted
- With increasing temperature it will be necessary to use a rheostat-setting at the center winding beginning with low values (i.e. 10%)
- **Quite often it is difficult to achieve a temperature profile of about 30mm length over the specimen better than +/-2 K**

7.2. Axial Deformation Calibration (external DCDT)

7.2.1. Initial Pre-Calibration of the DCDT (first installation)

- **The DCDT has got a linear range of +/- 12,5 mm**
- Vessel is open, no specimen inside
- Remove the furnace (described in section 9.1.1.)

- Measure with an appropriate tool (i.e. depth gauge) the distance between the top of the internal load cell (ILC) and the top of the top cap of the bottom plug from the top of the machine
- Move the axial actuator and with it the internal load cell to a position approx. 15 mm below the top of the top cap of the bottom plug (thickness of the top cap = 3 mm)
- Set the zero-potentiometer of the amplifier (Analog Devices **AD-3B41**) to the center position
- Install the DCDT in its holder, do not tighten the clamp
- Move the DCDT up or down in the holder to get an output of approx. **0,0 V** at a voltage channel of the data acquisition system (i.e. **Delphin**)
- Tighten the clamp of the holder to fix the position of the DCDT
- Adjust the output to **0,0 V** with the zero-potentiometer of the AD-3B41
- ➔ **This is position “Zero” for the calibration**
- Insert a gauge block of 12 mm in between the DCDT core tip and the bottom of the pressure vessel
- Set the span-potentiometer of the AD-3B41 to get an output of **10,0 V**
- ➔ **This is the maximum position for the calibration**
- Remove the gauge block

7.2.2. Calibration of the DCDT

- **The DCDT has got a linear range of +/- 12,5 mm**
- Move the axial actuator to position **“Zero”**
- Install a measuring clockwork in parallel to the DCDT





DCDT and clockwork installed at the back of the stirrup (vessel support)

- Move the axial actuator 12 mm down, measured with the measuring clockwork
- Set the measuring clockwork to **zero**
- Note the measured values of the measuring clockwork and the voltage output of the data acquisition system
- Move the axial actuator upwards stepwise (i.e. **0,5 mm** steps) and note the measured values [μm] and [mV] for each step
- Stop after a total movement of 24 mm (maximum)
- Move the axial actuator to position **"Zero"** again

- Calculate the slope A and the offset B of the graph (i.e. with the software Origin)

$$s(\text{clockwork})[\mu\text{m}] = A * s(\text{data acqu.})[\text{mV}] + B$$

- Calculate the position s_1 [μm] for **-10,0 V** and s_2 [μm] for **+10,0 V**
- Set

$$-10,0 \text{ V} \Rightarrow 0 \mu\text{m}$$

$$+10,0 \text{ V} \Rightarrow |s_1| + |s_2| [\mu\text{m}]$$

- Create a linearized channel [μm] with a table of values for the DCDT in the data acquisition system with the table values for -10,0 V to +10,0 V
- Repeat the calibration of the DCDT as in the first step and note the measured values of the measuring clockwork [μm] and the linearized DCDT-channel [μm] for each step
- Move the axial actuator to position “Zero” again
- Calculate the slope A and the offset B of the graph (i.e. with the software **Origin**)

$$s(\text{clockwork}) [\mu\text{m}] = A * s(\text{data acqu.}) [\mu\text{m}] + B$$

- **The calculated slope should be 1,0 with an acceptable tolerance**

7.3. Load Cell Calibration (→ Appendix A)

→ roughly described in Operator Manual : “Internal load/torque cell”, No.7, p.19...20

7.3.1. Theory

- **Calibration of the internal load cell** → +/-10,0 V = +/-100 kN (at 300 MPa)
- **Calibration spring** → 10,81 kN/mm = 1081 mV/mm (50 kN = 4626 μm)
- **Solid body** → almost stiff, very small deformation
- **Note:** The real deformation of the solid body is i.e. 15 μm at 50kN according to:

$$\Delta l(\text{sb}) = \frac{\sigma}{E} * l(\text{sb}) = \frac{4 F}{\pi * d(\text{sb}) * E} * l(\text{sb})$$

with: $\Delta l(\text{sb})$ → the shortening of the solid body
 E → the Young’s modulus of the steel of the solid body
 F → the acting force
 $d(\text{sb})$ → the diameter of the solid body (63mm)
 $l(\text{sb})$ → the length of the solid body (196mm)

Corresponding to experimental experience the real deformation of the solid body may be neglected for the calibration. The uncertainties in the measurement of the position/travel of the axial actuator, when loading the solid body several times to the same load (i.e. 50kN), are in the same order of magnitude as the above calculated deformation of the solid body (see Appendix B).

However, for a precise calibration of the internal load cell the deformation of the solid body has to be included.



- The specimen assembly, the calibration spring or the solid body inside the vessel together with the vessel itself, the top nut and the pistons of the bottom plug are parts of a series connection of springs following the law :

$$\frac{1}{C(\text{all})} = \frac{1}{C(\text{cs})} + \frac{1}{C(\text{vpn})} + \frac{1}{C(\text{sb})}$$

- with: C(all) → spring constant of the whole system
 C(cs) → spring constant of the calibration spring (calibrated at the MTS)
 C(vpn) → spring constant of the vessel et all (calculated at solid body test)
 and: C(sb) → spring constant of the solid body
 C(sa) → spring constant of the specimen assembly

7.3.2. Calibration Procedure

First Step - Calibration Spring

- Vessel is open, no specimen inside
- Remove the furnace (described in section 9.1.1.)
- Move the axial actuator to a position approx. 1 mm below position **“Zero”**
- Insert the spring bottom piston for the calibration spring into the inner anvil part (internal bayonet) of the internal load cell



spring bottom piston in the inner anvil part of the internal load cell

- Insert a ball (used in ball bearings) onto the spring bottom piston
- Insert the calibration spring on top of the ball
- Insert to cylinder segments into the vessel (to retain the calibration spring vertical and to reduce gas volume)



- Insert a second ball on top of the calibration spring



- Close the vessel with the top closure plug for the calibration spring

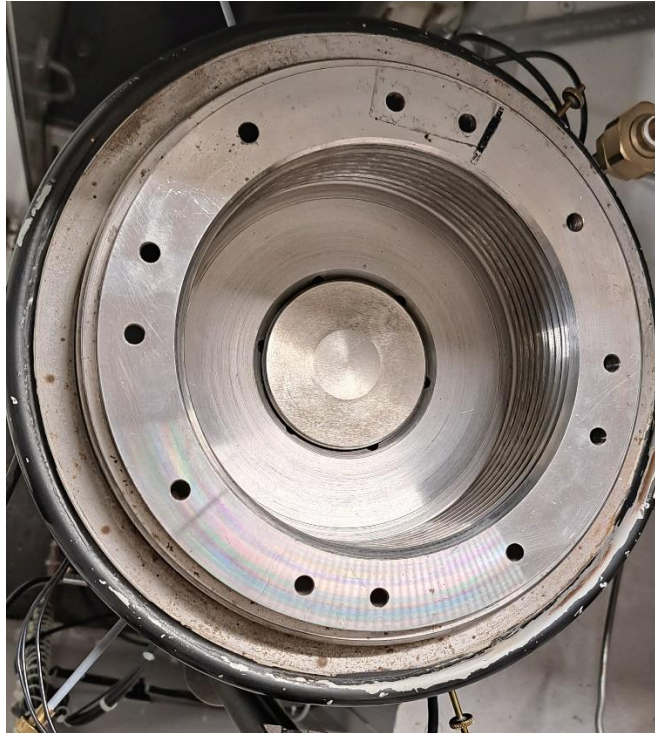

- Install and screw the vessel top nut down to the end of the thread, **do not tighten this nut**
- Increase gas pressure in the vessel to the usual pressure value (i.e. 300 MPa)
- Use a voltage channel at the data acquisition system (i.e. **Delphin**) for the signal of the internal load cell
- Set the measured voltage at this channel to **0,0 V** with the zero-potentiometer of the amplifier (Analog Devices **AD-3B18**)
- Move the axial actuator upwards to touch the calibration spring
- Load the calibration spring with a small load, i.e. **0,1 V** (approx. 1 kN)
- Note the measurement of the DCDT
- Continue moving the axial actuator slowly upwards another **4626 μm** (corresponding to 50 kN additional load on the calibration spring according to the spring constant)
- Set the measured voltage at the data acquisition system to **5,1 V (0,1 V + 5,0 V)** with the span-potentiometer of the **AD-3B18** (if you did not move 4626 μm exactly, calculate the voltage to set with the spring constant of the calibration spring assuming **5,0 V = 50 kN**)
- Move the axial actuator downwards and unload the calibration spring
- The measurement at the data acquisition should be **0,0 V**
- If the measurement is not **0,0 V (+/-0,2 mV)** repeat the steps starting from setting the data acquisition system to **0,0 V** again
- If necessary repeat this several times
- Move the axial actuator down to a position approx. 1 mm below position **"Zero"**, far away enough from the touch with the calibration spring

- Decrease the gas pressure and release all the gas out of the vessel
- Take out the calibration spring in reverse order, leave the ball and the spring bottom piston and on top of the internal load cell inside

Second Step - Solid Body

- Insert the solid body on top of the ball on the spring bottom piston

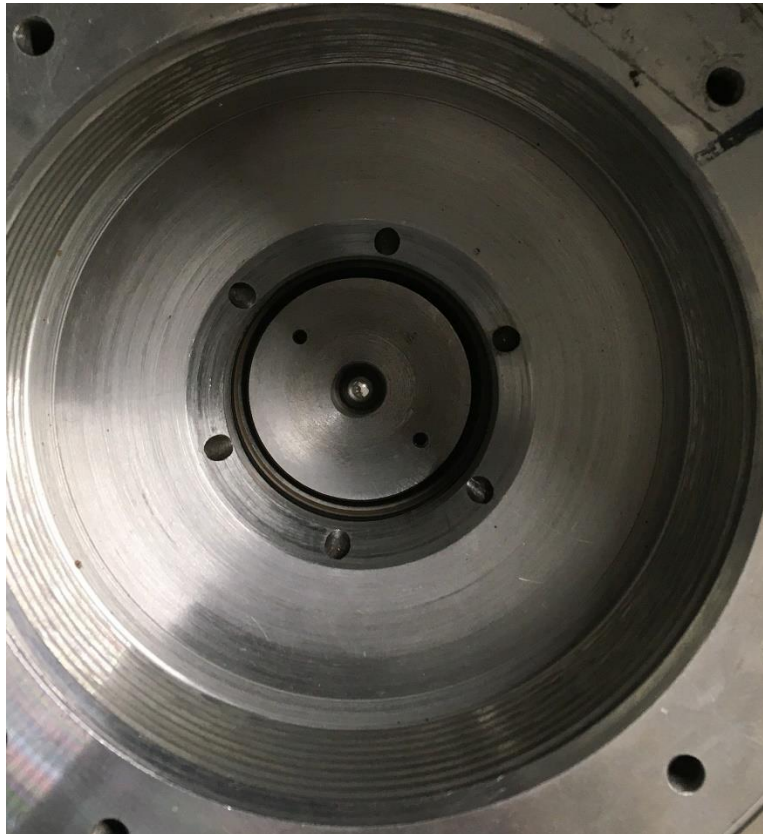

- Insert the second ball on top of the solid body
- Close the vessel with the top closure plug for the calibration spring
- Install and screw the vessel top nut down to the end of the thread, **do not tighten this nut**
- Increase gas pressure in the vessel to the same pressure as with the calibration spring before (i.e. 300 MPa, same pressure as in the first step)
- Note the measurement of the internal load cell, it should be about **0,0 V**
- Move the axial actuator upwards to touch the solid body
- Load the solid body with a small load, i.e. **0,3 V** (approx. 3 kN)
- Note the measurement of the DCDT and the internal load cell
- Continue moving the axial actuator slowly upwards about **5000 mV** (roughly corresponding to 50 kN load additional on the solid body)
- Note the measurement of the DCDT and the internal load cell
- Calculate the difference of the measurements for the displacement and the load

- Calculate the displacement [μm] per load [mV] of the differences
- Move the axial actuator downwards to a position approx. 1 mm below position “Zero”, far away enough from the touch with the solid body
- Repeat the steps of loading and unloading several times (i.e. 3...4 times)
- Calculate the average of the differences in displacement (**do not use the value of the first loading for this average**)
- **The average difference in displacement is the deformation of the vessel, the pistons etc. and the solid body at approx. 50 kN**
- **Consequently a movement of the axial actuator X_0 (i.e. 4626 μm) results in a real deformation of the calibration spring $Z(\text{cs})$ decreased by the deformation of the vessel and the pistons etc. $Y(\text{vpn})$ and the solid body $Y(\text{sb})$**

$$Z(\text{cs}) = X_0 - Y(\text{vpn}) - Y(\text{sb}) \text{ [mm]}$$

- **Consequently the real axial load is smaller than calculated**
- Calculate the stiffness of the system (vessel plus pistons plus top nut) and the solid body

$$1/C(\text{vpn}) = Y(\text{vpn})/50 \text{ kN}$$

$$1/C(\text{sb}) = Y(\text{sb})/50 \text{ kN}$$

- Consequently the spring constant of the whole system with the calibration spring inside the vessel is

$$1/C(\text{all}) = \{1/C(\text{cs}) + 1/C(\text{vpn}) + 1/C(\text{sb})\} = \text{___ mm/kN}$$

$$C(\text{all}) = \text{___ kN/mm}$$

- Decrease the gas pressure and release all the gas out of the vessel
- Take out the solid body in reverse order, leave the ball and the spring bottom piston on top of the internal load cell inside

Third Step - Calibration Spring

- Insert the calibration spring again (as described in the first step already)
- Insert the second ball on top of the calibration spring
- Close the vessel with the top closure plug for the calibration spring
- Install and screw the vessel top nut down to the end of the thread, **do not tighten this nut**
- Increase gas pressure in the vessel to the same pressure again

- Note the measurement of the internal load cell, it should be about **0,0 V**
- Move the axial actuator upwards to touch the calibration spring
- Load the calibration spring with a small load, i.e. **0,1 V** (approx. 1 kN)
- Note the measurement of the DCDT and the internal load cell
- **There are two possible ways to continue :**
 - **A: with the subtraction of the deformation of the vessel and the solid from the spring deformation**
 - **B: with the sum of all deformations**

Procedure A :

- Continue moving the axial actuator upwards approx. **$X_1 = 4600...4650 \mu\text{m}$**
- **Calculate the real amount of deformation of the calibration spring Z [mm] and calculate the corresponding force F [mV]**

$$Z(cs) = X_1 - Y(vpn) - Y(sb) \text{ [mm]}$$

$$F \text{ [mV]} = Z(cs) \text{ [mm]} * 10,81 \text{ [kN/mm]} * 100 \text{ [mV/kN]}$$

- Correct the measured voltage at the data acquisition system to the calculated voltage with the span-potentiometer of the **AD-3B18**
- Move the axial actuator downwards and unload the calibration spring
- The measurement at the data acquisition should be about **0,0 V**
- Create a linearized channel F [kN] for the internal load cell in the data acquisition system with the two values for $-10 \text{ V} = -100 \text{ kN}$ and $+10 \text{ V} = +100 \text{ kN}$
- Move the axial actuator upwards near to the touch of the calibration spring
- Start the data acquisition system and measure the channels s [μm] (DCDT) and internal load cell F [mV] and F [kN]
- Continue moving the axial actuator upwards approx. **4600...4650 μm**
- Move the axial actuator downwards and unload the calibration spring
- Repeat the loading and unloading of the calibration spring twice
- Calculate the slope m [kN/mm] with a linear fit of the graph (i.e. with the software **Origin**), it should correspond to the spring constant of the system calculated above

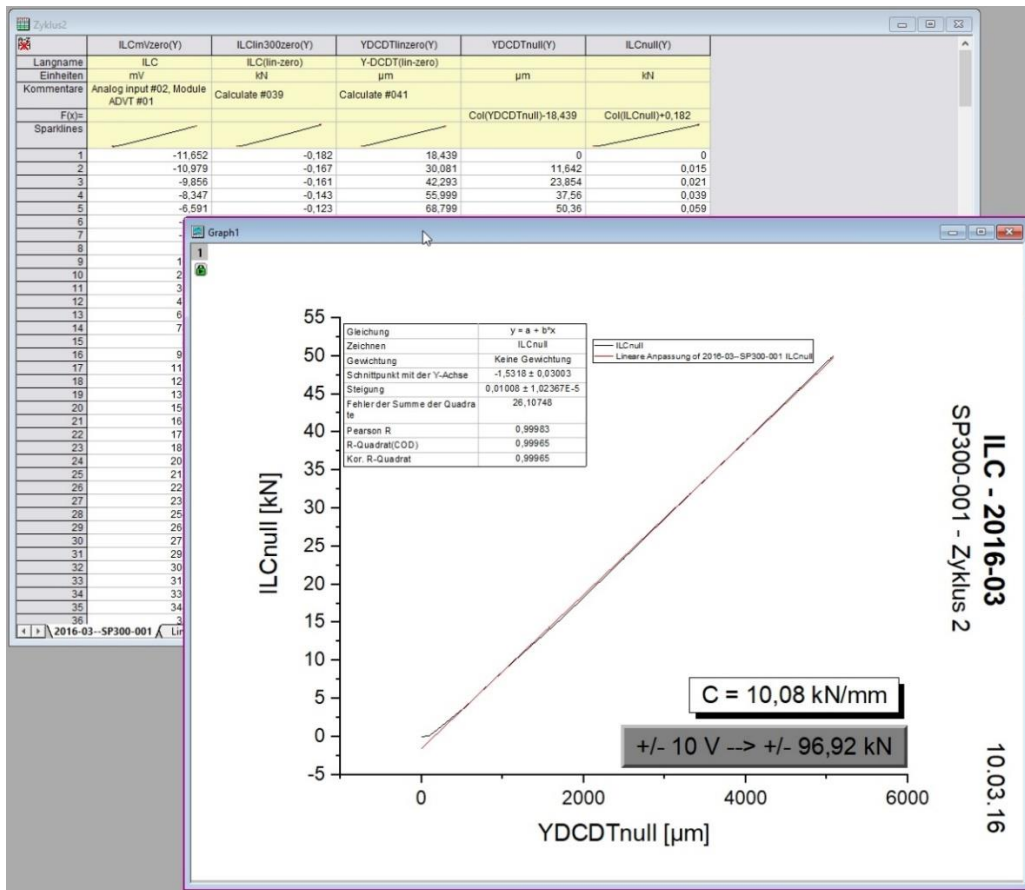

- Take the measured data of both channels of the internal load cell in the data acquisition system and create a table of values with x [mV] and y [kN]
- Insert this table of values into the linearized channel of the internal load cell

	ILCmVnull(Y)	B1(Y)	ILCcalc(Y)
e			
n	mV		kN
e			
=	Col(ILCmVnull)+10,012		Col(ILCcalc)*10,08/1040
s			
1	0,00		0,00
2	1,61		0,02
3	3,01		0,03
4	4,23		0,04
5	5,26		0,05
	6,12		0,06
	7,34		0,07
	13,58		0,13
	21,66		0,21
	30,94		0,30
	39,66		0,38
	48,35		0,47

→ (i.e. Delphin) :

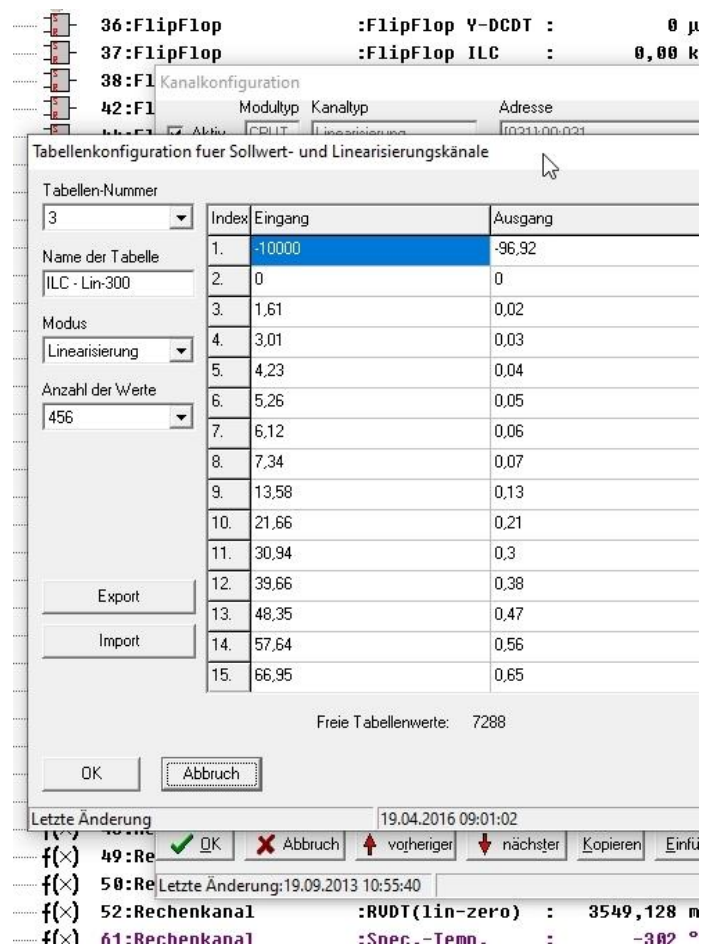

- Repeat this for different pressures (i.e. 400, 200, 100 MPa) and check the deflection
- Certainly, there will be a slight deflection, which may be small enough to tolerate
- However, depending on its value it may be necessary to repeat the calibration at different pressures and use different calibration values/slopes at different pressures

Procedure B :

- Calculate the displacement X_2 for $50 \text{ kN} = 5,0 \text{ V}$ with the deformation of the vessel, pistons and the solid

$$X_2 = Z(cs) + Y(vpn) + Y(sb) \text{ [mm]}$$

- Continue moving the axial actuator upwards to the calculated displacement
- Correct the measured voltage at the data acquisition system to $5,0 \text{ V}$ with the span-potentiometer of the **AD-3B18**
- Move the axial actuator downwards and unload the calibration spring
- The measurement at the data acquisition should be about $0,0 \text{ V}$

- Calculate the slope m [mV/mm] with a linear fit of the graph (i.e. with the software Origin)

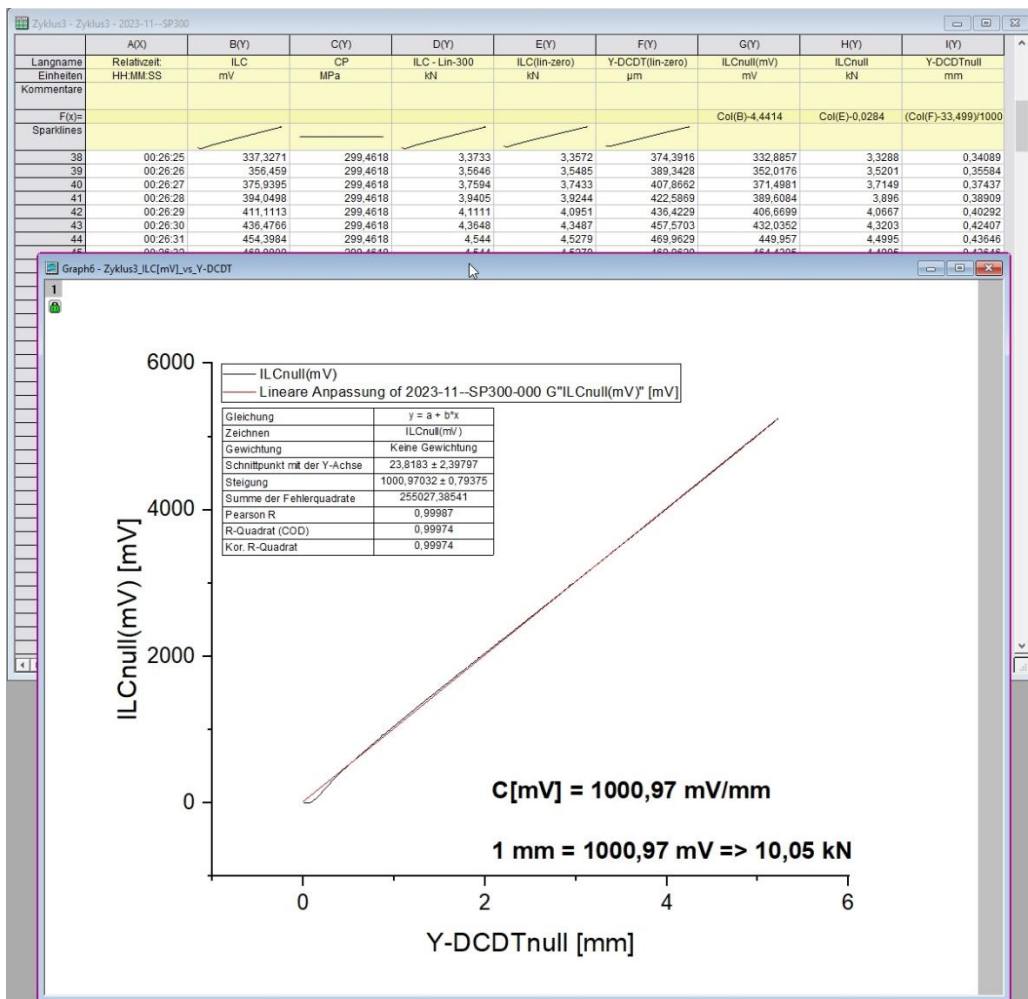

- Calculate with this slope m [mV/mm] and the calculated spring constant of the system $C(\text{all})$ [kN/mm] the internal load F [kN] for 10 V

$$F \text{ [kN]} = \frac{10 \text{ V} * C(\text{all}) \left[\frac{\text{kN}}{\text{mm}} \right]}{m \left[\frac{\text{mV}}{\text{mm}} \right]}$$

- Set the calculated values for channel F [kN] for the internal load cell in the data acquisition system for -10 V and +10 V
- Move the axial actuator upwards near to the touch of the calibration spring
- Start the data acquisition system and measure the channels s [μm] (DCDT) and internal load cell F [mV] and F [kN]
- Continue moving the axial actuator upwards approx. **4600...4650 μm**
- Move the axial actuator downwards and unload the calibration spring
- Repeat the loading and unloading of the calibration spring twice

- Calculate the slope m [kN/mm] with a linear fit of the graph (i.e. with the software **Origin**), it should correspond to the spring constant of the system calculated above

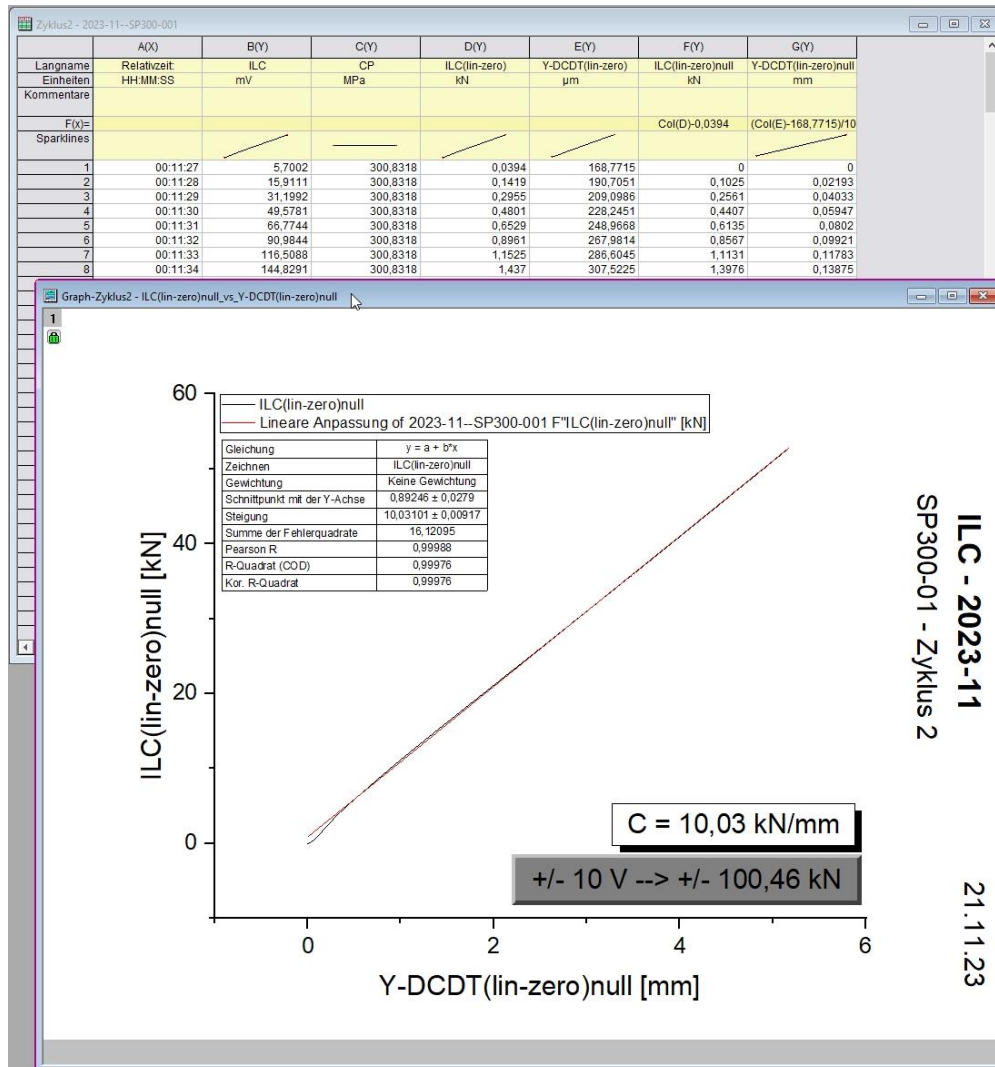

- Take the measured data of both channels of the internal load cell in the data acquisition system and create a table of values with x [mV] and y [kN]
- Insert this table of values into the linearized channel of the internal load cell

	A(X)	B(Y)
Langname	ILC(mV)null	ILC(lin-zero)null
Einheiten	mV	kN
Kommentare	Lin Fit	Lin Fit
F(x)=		
1	0,00	-0,01
2	583,79	5,86
3	1167,57	11,72
4	1751,36	17,59
5	2335,14	23,45
6	2918,93	29,32
7	3502,71	35,18
8	4086,50	41,05
9	4670,28	46,91
10	5254,07	52,78
11		
12		
13		
14		
15		
16		
17		
18		
19		

→ (i.e. Delphin) :

Kanalkonfiguration

Modultyp: CPU-T Kanaltyp: Linearisierung Adresse: [031]:00:031

Aktiv

Name: ILC - Lin-300 Einheit: kN

Langtext: Linearisation #031

Tabellenkonfiguration fuer Sollwert- und Linearisierungskanäle

Tabellen-Nummer: 3

Index	Eingang	Ausgang
1.	-10000	-100,46
2.	0	-0,01
3.	583,79	5,86
4.	1167,57	11,72
5.	1751,36	17,59
6.	2335,14	23,45
7.	2918,93	29,32
8.	3502,71	35,18
9.	4086,5	41,05
10.	4670,28	46,91
11.	5254,07	52,78
12.	10000	100,46

Name der Tabelle: ILC - Lin-300

Modus: Linearisierung

Anzahl der Werte: 12

Export Import

Freie Tabellenwerte: 7900

OK Abbruch

Letzte Änderung: 24.11.2023 11:10:20

- Repeat this for different pressures (i.e. 400, 200, 100 MPa) and check the deflection
- Certainly, there will be a slight deflection, which may be small enough to tolerate

- However, depending on its value it may be necessary to repeat the calibration at different pressures and use different calibration values/slopes at different pressures

7.3.3. ILC - Calibration-Check

- Vessel is open, no specimen inside
- Remove the furnace (described in section 9.1.1.)
- Move the axial actuator to a position approx. 1 mm below position **“Zero”**
- Insert the calibration spring (described in section 8.3.2.)
- Increase gas pressure in the vessel to the usual pressure value (i.e. 300 MPa)
- Move the axial actuator upwards near to the touch of the calibration spring
- Start the data acquisition system and measure the channels s [μm] (DCDT) and internal load cell F [mV]
- Continue moving the axial actuator upwards to approx. **5,0 V = 50 kN**
- Move the axial actuator downwards and unload the calibration spring
- Repeat the loading and unloading of the calibration spring twice
- Calculate the slope m [mV/mm] with a linear fit of the graph of the second and third loading (i.e. with the software **Origin**)

$$\text{ILCmVnull [mV]} = m * \text{YDCDTnull [mm]}$$

$$F \text{ [mV]} = m * s \text{ [mm]}$$

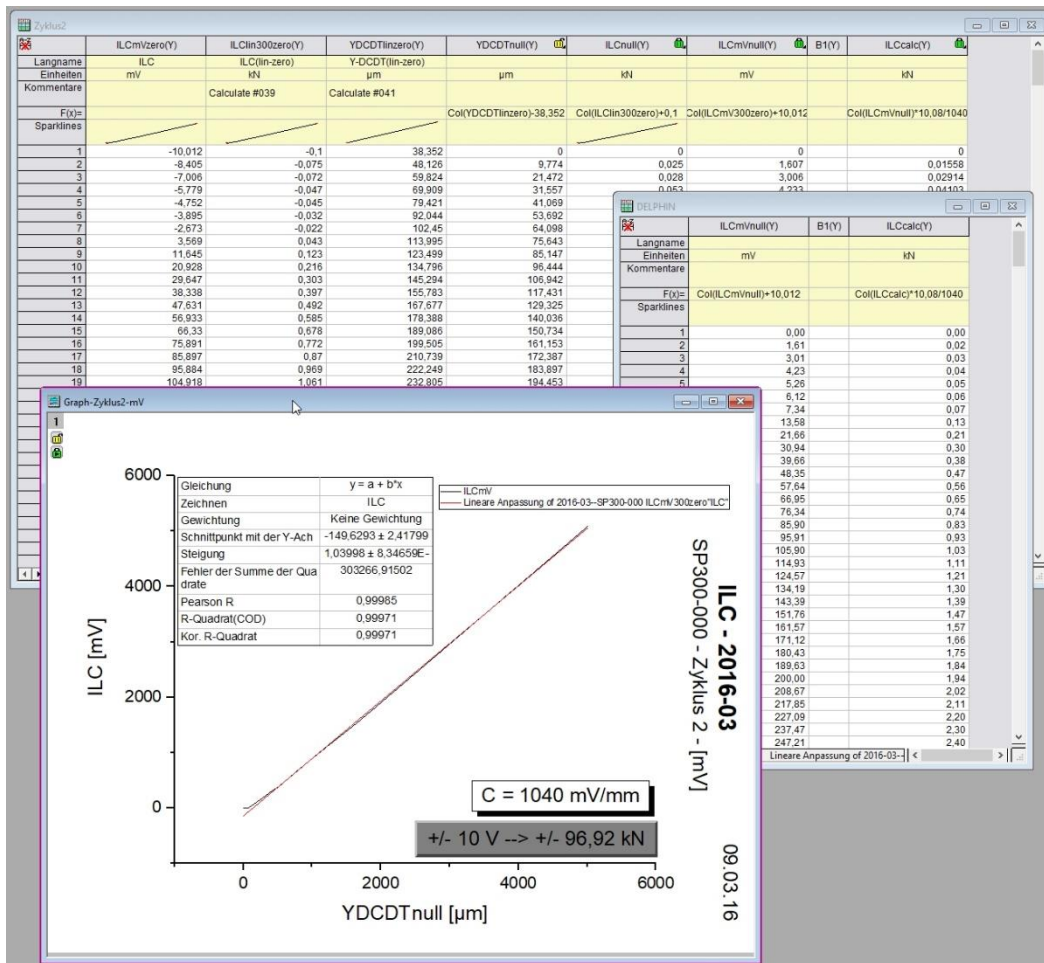

- Calculate with that slope m [mV/mm] and the spring constant of the system $C(\text{all})$ [kN/mm] the internal load F [kN]

$$ILC_{\text{calc}} [\text{kN}] = \frac{ILC_{\text{mVnull}} [\text{mV}] * C(\text{all}) \left[\frac{\text{kN}}{\text{mm}} \right]}{m \left[\frac{\text{mV}}{\text{mm}} \right]}$$

$$F [\text{kN}] = \frac{F [\text{mV}] * C(\text{all}) \left[\frac{\text{kN}}{\text{mm}} \right]}{m \left[\frac{\text{mV}}{\text{mm}} \right]}$$

- Take the measured F [mV] and calculated F [kN] data of the internal load cell and create a table of values in the data acquisition system with x [mV] and y [kN]
- Insert this table of values into the linearized channel of the internal load cell
- Move the axial actuator upwards near to the touch of the calibration spring
- Start the data acquisition system and measure the channels s [µm] (DCDT) and internal load cell F [kN]
- Continue moving the axial actuator upwards to approx. **50 kN**

- Move the axial actuator downwards and unload the calibration spring
- Repeat the loading and unloading of the calibration spring twice
- Calculate the slope m [kN/mm] with a linear fit of the graph (i.e. with the software **Origin**), it should correspond to the spring constant of the system calculated above

$$ILC_{null} \text{ [kN]} = m * YDCDT_{null} \text{ [mm]}$$

$$F \text{ [kN]} = m * s \text{ [mm]}$$

$$C(\text{all}) = m = \underline{\hspace{2cm}} \text{ kN/mm}$$

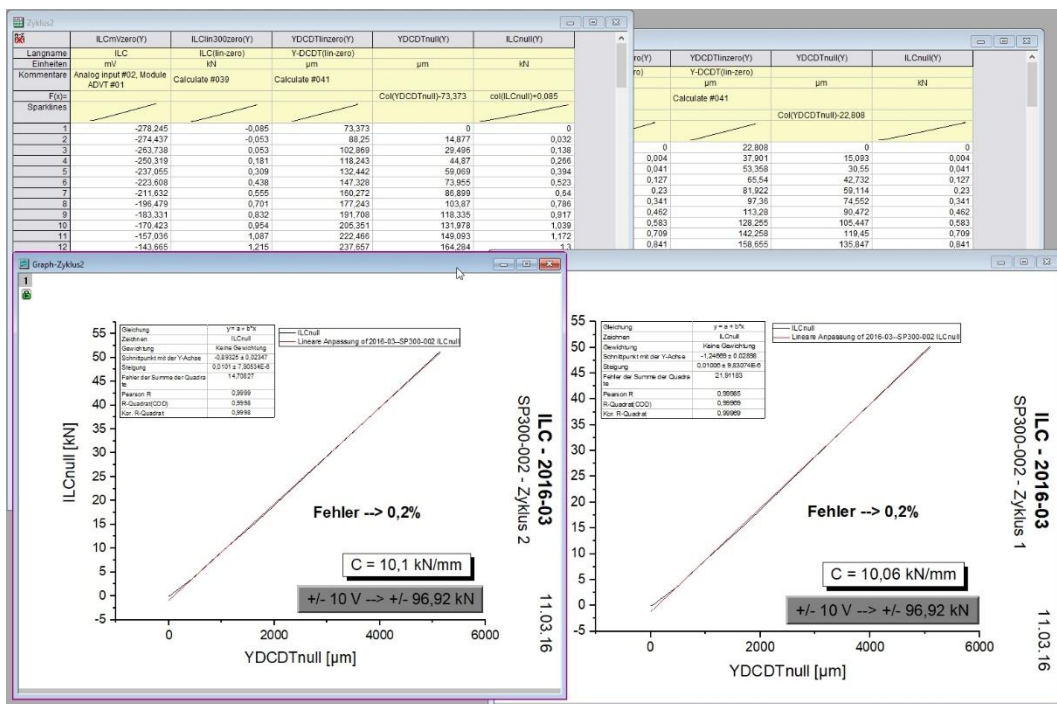

7.4. Twist Calibration

7.4.1. Initial Pre-Calibration of the RVDT (first installation)

- **The RVDT has got a linear range of +/- 40° (corresponding to +/-0,6981 rad)**
- Vessel is prepared for the first step of the calibration of the internal torque cell and closed with the torsion top nut with the torsion actuator attached to the vessel (described in section 8.5.2.)
- Attach one of the 1:1-wheels and an angle meter on top of this wheel at the shaft of the RVDT making sure, that the mark at the wheel and 0° at the angle meter overlap
- Attach the second 1:1-wheel at the shaft of the torsion driver, making sure that the marks at both wheels overlap
- Set the zero-potentiometer of the amplifier (Analog Devices **AD-3B41**) to the center position
- Use a voltage channel at the data acquisition system (i.e. **Delphin**) for the signal of the RVDT
- Adjust the output to **0,0 V** with the zero-potentiometer of the AD-3B41
- Retain the angle position of the wheel at the shaft of the torsion driver
- Rotate manually the wheel at the shaft of the RVDT clockwise until **+40°** at the angle meter overlap with the mark at the retained wheel
- Set the span-potentiometer of the AD-3B41 to get an output of **10,0 V**
- Check the output signal at the angle position **-40°** counterclockwise, this should be about **-10,0 V**

7.4.2. Calibration of the RVDT

- **The RVDT has got a linear range of +/- 40° (corresponding to +/-0,6981 rad)**
- Vessel is prepared for the first step of the calibration of the internal torque cell and closed with the torsion top nut with the torsion actuator attached to the vessel (described in section 8.5.2.)
- The 1:1-wheels are installed (described in section 8.4.1.)
- Retain the angle position of the wheel at the shaft of the torsion driver
- Rotate manually the wheel at the shaft of the RVDT counterclockwise until **-40°** at the angle meter overlap with the mark at the retained wheel
- Note the measured values of the angle meter and the voltage output of the data acquisition system
- Continue rotating the wheel stepwise (i.e. **5°** steps) and note the measured values [°] and [mV] for each step
- Stop after a total rotation of **80°** (corresponding to **+40°** at the angle meter)
- Rotate the wheel back to the starting position (0° at the angle meter)
- Calculate the measured angles [mrad] of the angle meter

- Calculate the slope A and the offset B of the graph (i.e. with the software Origin)

$$\Theta(\text{angle meter}) [\text{mrad}] = A * \Theta(\text{data acqu.}) [\text{mV}] + B$$

- Calculate the angle Θ_1 [mrad] for -10,0 V and Θ_2 [mrad] for +10,0 V
- Set

$$-10,0 \text{ V} \Rightarrow 0 \text{ mrad}$$

$$+10,0 \text{ V} \Rightarrow |\Theta_1| + |\Theta_2| [\text{mrad}]$$

- Create a linearized channel [mrad] with a table of values for the RVDT in the data acquisition system with the two values for -10,0 V and +10,0 V
- Repeat the calibration of the RVDT as in the first step and note the measured values of the angle meter [°] and the linearized RVDT-channel [mrad] for each step
- Rotate the wheel back to the starting position (0° at the angle meter)
- Calculate the measured angles [mrad] of the angle meter
- Calculate the slope A and the offset B of the graph (i.e. with the software **Origin**)

$$\Theta(\text{angle meter}) [\text{mrad}] = A * \Theta(\text{data acqu.}) [\text{mrad}] + B$$

- The calculated slope should be **1,0** with an acceptable tolerance

7.5. Torque Cell Calibration (→ Appendix B)

- roughly described in Operator Manual : “Internal torque measurement and calibration”, No.7, p.29
- the calibration is done counterclockwise, as usual direction of experiments
- due to the low coefficient of friction between the pistons (experimental experience) the torque is limited and the calibration is performed up to +/-100 Nm approx.

7.5.1. Theory

- **Calibration of the internal torque cell** → +/-10,0 V = +/-100 Nm (at 400 MPa)
- **Thin torsion calibrating bar** → d=15 mm, l=226 mm, 83 GPa
- **Thick torsion calibrating bar** → d=26 mm, l=226 mm, 83 GPa
- **There are two more calibrating bars with smaller diameter (d=12mm, d=18mm) useful for a calibration check**



- The specimen assembly for torsion experiments or one of the torsion calibrating bars inside the vessel together with the vessel itself are parts of a series connection of torsion springs
- The twist (torsion deformation) of the vessel under a certain torque should be equal to the difference in twist of a torsion calibrating bar measured and calculated with the same torque
- With two torsion calibrating bars it is possible to calibrate the internal torque cell in an **iterative process**
- Calculate the theoretical twist of both torsion calibrating bars for $M=90 \text{ Nm}$

$$\theta(c) = \frac{32 M l}{\pi G d^4}$$

- with:
- $\theta(c)$ → calculated twist
 - M → torque = 90 Nm
 - l → length of the calibrating bars = 226 mm ($l = l_{15} = l_{26}$)
 - d → diameter of the calibrating bars = 15 mm and 26 mm respectively
 - G → shear modulus of the material of the calibrating bars = 83 GPa

- Measure the twist of both torsion calibrating bars loaded counterclockwise with a torque of 90Nm at the same pressure (i.e. 400 MPa)
- Calculate the torque with the measured twist of both torsion calibrating bars

$$M = \frac{\pi G [\theta(m)_{15} - \theta(m)_{26}]}{32 \left(\frac{l_{15}}{d_{15}^4} - \frac{l_{26}}{d_{26}^4} \right)}$$

$$M \text{ [Nm]} = 2,053 [\theta(m)_{15} - \theta(m)_{26}] \text{ [mrad]}$$

with: $\theta(m)_{15}$ → measured twist of the thin torsion calibrating bar
 $\theta(m)_{26}$ → measured twist of the thick torsion calibrating bar

- **The calculated torque should be 90 Nm (theoretically)**
- Calculate the differences in theoretical and measured twist for both calibrating bars

$$\theta(m)_{15} - \theta(c)_{15} = \theta(m)_{26} - \theta(c)_{26}$$

with: $\theta(c)_{15}$ → calculated twist of the thin torsion calibrating bar
 $\theta(m)_{15}$ → measured twist of the thin torsion calibrating bar
 $\theta(c)_{26}$ → calculated twist of the thick torsion calibrating bar
 $\theta(m)_{26}$ → measured twist of the thick torsion calibrating bar

- **The differences in twist should be equal**

7.5.2. Calibration Procedure

First Step - Thin Torsion Calibrating Bar (d=15mm)

- Vessel is open, no specimen inside
- Remove the furnace (described in section 9.1.1.)
- Move the axial actuator to a position approx. 1 mm below position “Zero”
- Remove the torsion insert for the specimen assembly (small splines to big splines) out of the internal load and torque cell
- Insert the dummy furnace steel cylinder into the vessel in order to decrease the volume of gas
- Insert the furnace top plug or the furnace top plug dummy into the vessel
- Install and screw the vessel top nut for torsion down to the end of the thread, **do not tighten this nut**
- Insert the thin torsion calibrating bar and push it completely down into the splines of the internal load and torque cell
- Place the torsion driver (external torque cell) onto the top end of the calibrating bar and into the conical seat at the torsion top nut
- Move the axial actuator (up or down) to a position, that the torsion driver is a very tiny bit pushed out of the conical seat at the torsion top nut, **make sure the dog-teeth are engaged**
- Note the measurement of the DCDT
- Install the torsion actuator on top of the vessel

- Screw the nut of the torsion actuator down to the end of the thread, **tighten this nut gently**
- Install the 1:1-wheels at the shaft of the RVDT and the torsion driver respectively
- Increase gas pressure in the vessel to the usual pressure value (i.e. 400 MPa)

- Move the axial actuator upwards to touch the torsion calibrating bar
- Remove the axial actuator about some tenth of a millimeter
- Use a voltage channel at the data acquisition system (i.e. **Delphin**) for the signal of the internal torque cell
- Set the measured voltage at this channel to **0,0 V** with the zero-potentiometer of the amplifier (Analog Devices **AD-3B18**)
- Run the torsion actuator counterclockwise to touch the splines in the internal torque cell (positive touch)
- Note the measurement of the RVDT
- Run the torsion actuator clockwise to touch the splines in the internal torque cell (negative touch)
- Note the measurement of the RVDT
- Run the torsion actuator counterclockwise and stop it in between the two torsion touch points
- Set the measured voltage at the internal torque cell channel to **0,0 V** with the zero-potentiometer of the amplifier (Analog Devices **AD-3B18**) again

- Run the torsion actuator counterclockwise to load the torsion calibrating bar with a small torque, i.e. **0,1 V** (approx. 1 Nm)
- Note the measurement of the RVDT
- Continue moving the torsion actuator counterclockwise to an angle which is the sum of the just measured angle and the calculated twist of this calibrating bar (corresponding to **91 Nm** torque on the calibrating bar theoretically)
- Set the measured voltage at the data acquisition system to **9,1 V (0,1 V + 9,0 V)** with the span-potentiometer of the **AD-3B18** (if you did not move exactly this angle, calculate again the voltage to set with this angle)
- Move the torsion actuator clockwise and unload the calibrating bar
- The measurement at the data acquisition should be about **0,0 V**

- Move the axial actuator down to a position approx. 1mm below the position notated before at room pressure
- Decrease the gas pressure and release all the gas out of the vessel
- Take out the thin torsion calibrating bar in reverse order

Second Step - Thick Torsion Calibrating Bar (d=26mm)

- Insert the thick torsion calibrating bar and push it completely down into the splines of the internal load and torque cell
- Place the torsion driver (external torque cell) onto the top end of the calibrating bar and into the conical seat at the torsion top nut
- Move the axial actuator (up or down) to a position, that the torsion driver is a very tiny bit pushed out of the conical seat at the torsion top nut, **make sure the dog-teeth are engaged**

- Note the measurement of the DCDT (should be approx. the same as with the thin calibrating bar)
- Install the torsion actuator on top of the vessel
- Screw the nut of the torsion actuator down to the end of the thread, **tighten this nut gently**
- Install the 1:1-wheels at the shaft of the RVDT and the torsion driver respectively
- Increase gas pressure in the vessel to the usual pressure value (i.e. 400 MPa, same pressure as in the first step)

- Move the axial actuator upwards to touch the torsion calibrating bar
- Remove the axial actuator about some tenth of a millimeter
- The measurement at the data acquisition should be about **0,0 V**
- Run the torsion actuator counterclockwise to touch the splines in the internal torque cell
- Note the measurement of the RVDT
- Run the torsion actuator clockwise to touch the splines in the internal torque cell
- Note the measurement of the RVDT
- Run the torsion actuator counterclockwise and stop it in between the two torsion touch points

- Run the torsion actuator counterclockwise to load the torsion calibrating bar with a small torque, i.e. **0,1 V** (approx. 1 Nm)
- Note the measurement of the RVDT
- Continue moving the torsion actuator counterclockwise to a torque of **9,1 V (0,1 V + 9,0 V)** corresponding to **91 Nm** torque on the calibrating bar theoretically
- Note the measurement of the RVDT
- Move the torsion actuator clockwise and unload the calibrating bar
- The measurement at the data acquisition should be about **0,0 V**

- Move the axial actuator down to a position approx. 1mm below the position notated before at room pressure
- Decrease the gas pressure and release all the gas out of the vessel
- Take out the thick torsion calibrating bar in reverse order

- Calculate the torque using the differences in twist/angle of each torsion calibrating bar (described in section 8.5.1.)
- **This torque will be smaller than 90 Nm**

- Calculate the corrected twist of the thin torsion calibrating bar to be measured (**first step of iteration**)

$$\theta(\text{mcorr1})_{15} = \theta(\text{m})_{26} - \theta(\text{c})_{26} + \theta(\text{c})_{15}$$

- with: $\theta(\text{c})_{15}$ → calculated twist of the thin torsion calibrating bar
 $\theta(\text{mcorr1})_{15}$ → **corrected twist** of the thin torsion calibrating bar
 $\theta(\text{c})_{26}$ → calculated twist of the thick torsion calibrating bar
 $\theta(\text{m})_{26}$ → measured twist of the thick torsion calibrating bar

Third Step - Thin Torsion Calibrating Bar

- Insert the thin torsion calibrating bar again as described in the first step already
- Repeat all steps as described in the first step already until the torsion actuator is positioned in between the two torsion touch points
- Run the torsion actuator counterclockwise to load the torsion calibrating bar with a small torque, i.e. **0,1 V** (approx. 1 Nm)
- Note the measurement of the RVDT
- Continue moving the torsion actuator counterclockwise to an angle which is the sum of the just measured angle and the **corrected twist** of this calibrating bar (calculated before in the first iteration step)
- Set the measured voltage at the data acquisition system to **9,1 V (0,1 V + 9,0 V)** with the span-potentiometer of the **AD-3B18**
- Move the torsion actuator clockwise and unload the calibrating bar
- The measurement at the data acquisition should be about **0,0 V**
- Move the axial actuator down to a position approx. 1mm below the position notated before at room pressure
- Decrease the gas pressure and release all the gas out of the vessel
- Take out the thin torsion calibrating bar in reverse order

Fourth Step - Thick Torsion Calibrating Bar

- Insert the thick torsion calibrating bar again as described in the second step already
- Repeat all steps as described in the second step already until the torsion actuator is positioned in between the two torsion touch points
- Run the torsion actuator counterclockwise to load the torsion calibrating bar with a small torque, i.e. **0,1 V** (approx. 1 Nm)
- Note the measurement of the RVDT
- Continue moving the torsion actuator counterclockwise to a torque of **9,1 V (0,1 V + 9,0 V)** corresponding to **91 Nm** torque on the calibrating bar
- Note the measurement of the RVDT
- Move the torsion actuator clockwise and unload the calibrating bar
- The measurement at the data acquisition should be about **0,0 V**
- Move the axial actuator down to a position approx. 1mm below the position notated before at room pressure
- Decrease the gas pressure and release all the gas out of the vessel
- Take out the thick torsion calibrating bar in reverse order
- Calculate the torque using the differences in twist/angle of each torsion calibrating bar (described in section 8.5.1.)
- **This torque will be smaller than 90 Nm again**

- Calculate again the corrected twist of the thin torsion calibrating bar to be measured (second step of iteration)

$$\Theta(\text{mcorr}2)_{15} = \Theta(m)_{26} - \Theta(c)_{26} + \Theta(c)_{15}$$

- Repeat these iteration steps (if necessary several times) until the calculated torque (section 8.5.1.) equals 90 Nm within a small acceptable tolerance

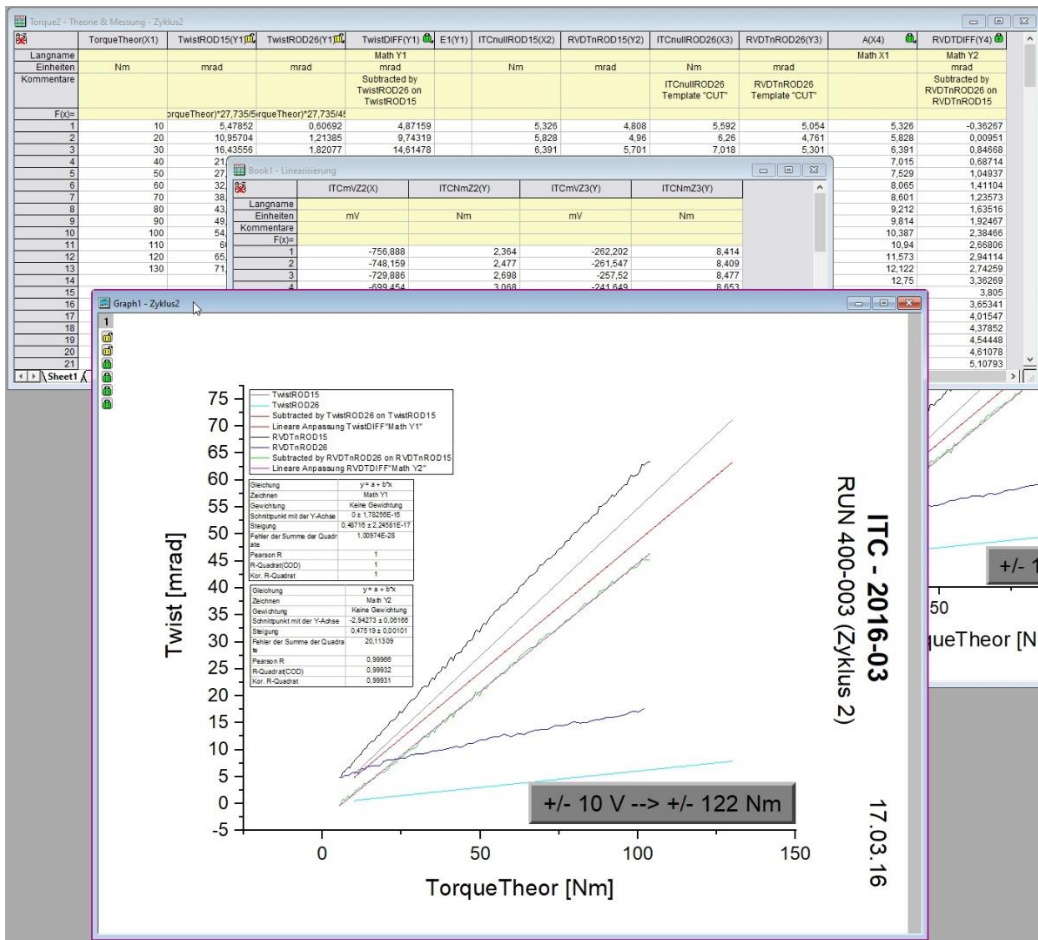

- Take the measured data of both channels of the internal torque cell in the data acquisition system and create a table of values with x [mV] and y [Nm]
- Insert this table of values into the linearized channel of the internal torque cell

	ITCmVZ3(Y)	ITCNmZ3(Y)
	mV	Nm
34	-262,202	8,414
37	-261,547	8,409
38	-257,52	8,477
38	-241,649	8,653
38	-217,266	8,95
38	-184,711	9,341
34	-155,181	9,705
39	-116,713	10,172
39	-79,942	10,626
38	-45,624	11,046
39	-5,778	11,517
33	39,045	12,071
38	74,443	12,507
39	115,243	13,003
32	158,909	13,533
35	207,745	14,131
39	250,902	14,66
33	293,402	15,168
39	338,641	15,721
35	386,533	16,307
36	435,105	16,903
38	483,028	17,485
31	525,738	18,012

→ (i.e. Delphin) :

36:FlipFlop :FlipFlop V-DCDT : 0 µm
 37:FlipFlop :FlipFlop ILC : 0,00 kN
 38:F1 Kanalkonfiguration
 42:F1 Modultyp Kanaltyp Adresse

Tabellenkonfiguration fuer Sollwert- und Linearisierungskanäle

Tabellen-Nummer: 4
 Name der Tabelle: ITC - Lin-400
 Modus: Linearisierung
 Anzahl der Werte: 167

Index	Eingang	Ausgang
1.	-10000	-122
2.	-262,202	8,414
3.	-261,547	8,409
4.	-257,52	8,477
5.	-241,649	8,653
6.	-217,266	8,95
7.	-184,711	9,341
8.	-155,181	9,705
9.	-116,713	10,172
10.	-79,942	10,626
11.	-45,624	11,046
12.	-5,778	11,517
13.	39,045	12,071
14.	74,443	12,507
15.	115,243	13,003

Freie Tabellenwerte: 7288

Letzte Änderung: 19.04.2016 09:01:02

49:Re OK Abbruch vorheriger nächster Kopieren Einfügen Hilfe
 50:Re Letzte Änderung:19.04.2016 09:01:36
 52:Rechenkanal :RUDT(lin-zero) : 3556,269 mrad

7.5.3. ITC - Calibration-Check

First Step - Thin Torsion Calibrating Bar

- Insert the thin torsion calibrating bar as described in section 8.5.2.
- Repeat all steps as described in section 8.5.2. until the torsion actuator is positioned in between the two torsion touch points
- Run the torsion actuator counterclockwise up to a torque of 100 Nm
- Repeat this torsion loading several times (i.e. 2...4 times)
- Measure the twist [mrad] and the torque [Nm] with a data acquisition system (i.e. **Delphin**)

Second Step - Thick Torsion Calibrating Bar

- Insert the thick torsion calibrating bar as described in section 8.5.2.
- Repeat all steps as described in section 8.5.2. until the torsion actuator is positioned in between the two torsion touch points
- Run the torsion actuator counterclockwise up to a torque of 100 Nm
- Repeat this torsion loading several times (i.e. 2...4 times)
- Measure the twist [mrad] and the torque [Nm] with a data acquisition system (i.e. **Delphin**)

Third Step - Calculations

- **Do not use any values of the first loading for the following calculations**
- Calculate the differences in twist **in the graph** for the calculated theoretical torques for both torsion calibrating bars (i.e. with the software **Origin**) as shown in the table and the graph – **TwistDIFF(Y1)**
- Calculate the differences in twist **in the graph** for the measured torques for both torsion calibrating bars (i.e. with the software **Origin**) as shown in the table and the graph – **A(X4) & RVDTDIFF(Y4)**

Langname	TorqueTheor(X1)	TwistROD15(Y1)	TwistROD26(Y1)	TwistDIFF(Y1)	E1(Y1)	ITCnullROD15(X2)	RVDtRROD15(Y2)	ITCnullROD26(X3)	RVDtRROD26(Y3)	A(X4)	RVDtDIFF(Y4)
Einheiten	Nm	mrاد	mrاد	mrاد		Nm	mrاد	Nm	mrاد	Math X1	Math Y2
Kommentare				Subtracted by TwistROD26 on TwistROD15				ITCnullROD26 Template "CUT"	RVDtRROD26 Template "CUT"		Subtracted by RVDtRROD26 on RVDtRROD15
F(x)=		orqueTheor(27.7355;orqueTheor)27.7355/4									
1	10	5,47852	0,60692	4,87159		5,326	4,808	5,592	5,054	5,326	-0,36267
2	20	10,95704	1,21385	9,74319		5,828	4,96	6,26	4,761	5,828	0,00951
3	30	16,43556	1,82077	14,61478		6,391	5,701	7,018	5,301	6,391	0,84668
4	40	21,91407	2,4277	19,48638		7,015	5,986	7,834	5,302	7,015	0,68714
5	50	27,39259	3,03462	24,35797		7,529	6,351	8,621	5,37	7,529	1,04937
6	60	32,87111	3,64155	29,22956		8,065	6,733	9,443	5,762	8,065	1,41104
7	70	38,34963	4,24847	34,10116		8,601	6,604	10,362	5,852	8,601	1,23573
8	80	43,82815	4,8554	38,97275		9,212	7,287	11,308	5,895	9,212	1,63516
9	90	49,30667	5,46232	43,84434		9,814	7,723	12,393	6,54	9,814	1,92467
10	100	54,78519	6,06925	48,71594		10,387	8,237	13,303	6,37	10,387	2,38466
11	110	60,2637	6,67617	53,58753		10,94	8,528	14,439	6,912	10,94	2,66805
12	120	65,74222	7,2831	58,45913		11,573	8,971	15,593	7,05	11,573	2,94114
13	130	71,22074	7,89002	63,33072		12,122	9,114	16,714	7,018	12,122	2,74259
14						12,75	9,836	18,056	7,055	12,75	3,36269
15						13,303	10,175	19,327	7,897	13,303	3,805
16						13,889	10,303	20,428	8,106	13,889	3,65341
17						14,394	10,806	21,909	8,185	14,394	4,01547
18						15,112	11,371	23,325	8,258	15,112	4,37852
19						15,68	11,592	24,723	8,4	15,68	4,54448
20						16,251	11,642	26,36	8,494	16,251	4,61078
21						16,898	12,131	27,98	9,088	16,898	5,10793

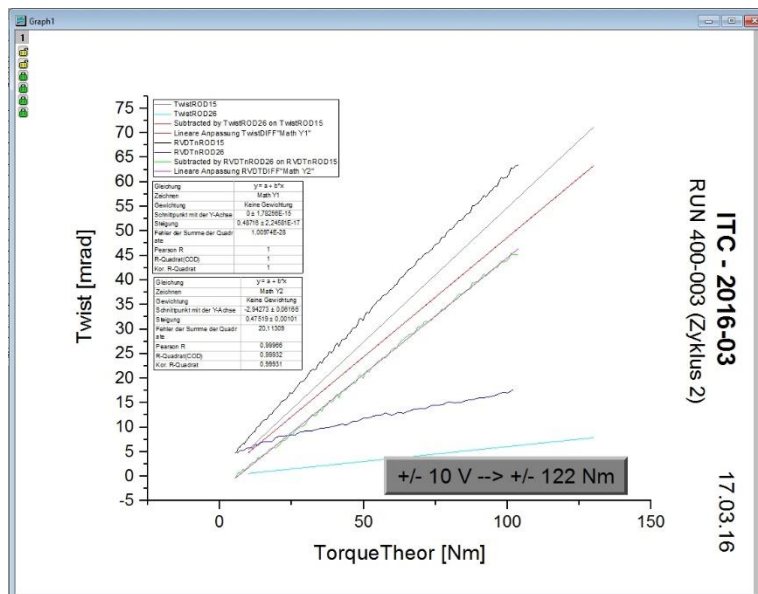

- Take the new measured data of both channels of the internal torque cell in the data acquisition system and create a new table of values with x [mV] and y [Nm]
- Correct with this new table of values the linearized channel of the internal torque cell

Langname	ITCmVZ2(X)	ITCNmZ2(Y)	ITCmVZ3(Y)	ITCNmZ3(Y)
Einheiten	mV	Nm	mV	Nm
Kommentare				
F(x)=				
1	-756,888	2,364	-262,202	8,414
2	-748,159	2,477	-261,547	8,409
3	-729,886	2,698	-257,52	8,477
4	-699,454	3,068	-241,649	8,653
5	-669,871	3,418	-217,266	8,95
6	-633,894	3,868	-184,711	9,341
7	-598,936	4,294	-155,181	9,705
8	-566,036	4,69	-116,713	10,172
9	-524,181	5,19	-79,942	10,626
10	-482,861	5,708	-45,624	11,046
11	-447,969	6,129	-5,778	11,517
12	-410,705	6,583	39,045	12,071
13	-361,55	7,178	74,443	12,507
14	-319,771	7,69	115,243	13,003
15	-278,606	8,192	158,909	13,533
16	-232,929	8,755	207,745	14,131
17	-180,987	9,379	250,902	14,66
18	-139,847	9,893	293,402	15,168
19	-94,994	10,429	338,641	15,721
20	-51,562	10,965	386,533	16,307
21	-1,366	11,576	435,105	16,903
22	47,895	12,178	483,028	17,485
23	94,429	12,751	525,738	18,012
24	139,568	13,304	578,502	18,647
25	191,997	13,937	623,58	19,203
26	237,875	14,486	671,915	19,791
27	288,179	15,114	717,779	20,353
28	333,404	15,667	761,093	20,906

7.6. Axial Stiffness Calibration

- For the stiffness calibration ordinary experimental setups of different sample lengths are used with a sample diameter of 10 mm (described in Operator Manual : “Specimen assembly”)
- The sample length is 16, 20, 24 mm preferably
- The sample material is a hard metal (i.e. tungsten carbide) or very dense alumina oxide for elevated temperatures
- Experiments are carried out in constant displacement mode up to an appropriate axial load at different pressures and room temperature and at elevated temperatures, if necessary (described in section 5 and in Operator Manual : “Deformation testing procedure” – No.4: p.16ff; No.7: p.18ff)

7.7. Axial Jacket Correction

- For the jacket correction ordinary experimental setups are used with a sample of 10 mm diameter and 20 mm length (described in Operator Manual : “Specimen assembly”)
- The sample material is used corresponding to the material of the jacket (i.e. low carbon steel C15, copper, ...)
- Experiments are carried out in constant displacement mode up to an appropriate axial load at different pressures and room temperature and at elevated temperatures, if necessary (described in section 5 and in Operator Manual : “Deformation testing procedure” – No.4: p.16ff; No.7: p.18ff)

7.8. Torsion Stiffness Calibration

- For the torsion stiffness calibration ordinary experimental setups for torsion tests are used with a sample diameter of 15 mm diameter and 10 mm length (described in Operator Manual : “Specimen assembly”)
- The sample material is the same low carbon steel C15 as used for the jackets
- Experiments are carried out in constant twist mode up to an appropriate torque load at different pressures and room temperature and at elevated temperatures, if necessary (described in section 5 and in Operator Manual : “Torsion testing procedure” – No.7: p.27ff)

7.9. Torsion Jacket Correction

- For the torsion jacket correction ordinary experimental setups for torsion tests are used with a sample of 15 mm diameter and 10 mm length (described in Operator Manual : “Specimen assembly”)
- The sample material is used corresponding to the material of the jacket (i.e. low carbon steel C15, copper, ...)
- Experiments are carried out in constant twist mode up to an appropriate torque load at different pressures and room temperature and at elevated temperatures, if necessary (described in section 5 and in Operator Manual : “Torsion testing procedure” – No.7: p.27ff)

8. Furnace

8.1. Furnace Specification

- ➔ described in Operator Manual : “High Temperature System”, No.7, p.14
- Furnaces used to be assembled with a tube made of alumina oxide, however, these tubes do not show a sufficient life-time, they crack quite often at the top and/or bottom winding after short times at elevated temperatures above 1000 °C
- In the past different materials were tested, i.e. different types of alumina oxide, sialon, alumina nitride and silica nitride
- Tubes of silica nitride showed the best results in life-time, those tubes even do not crack after several thousand hours of usage in different furnaces at elevated temperatures above 1000 °C

- The dimensions of a furnace tube is documented in detail in the drawings available
- There are no spiral grooves in the tube anymore
- The windings are made of pure molybdenum wire with a **diameter of 0,5 mm** :
 - **Plansee : ML-wire**
 - **Mo : >99 %**
 - **La : 0,19...0,31 %**
 - **La₂O₃ : 0,22...0,36 %**
- The **slope** of each winding is **1,25**
- The windings have a length and estimated turns of :
 - **Bottom : 30 mm & 24 turns**
 - **Center : 41 mm & 32 turns**
 - **Top : 18 mm & 14 turns**
- The windings are wound around the furnace tube and fixed with ceramic putty/glue (Ceramabond 569)
- The cold leads of the windings consist of three twisted wires each and are separated by 120° from one winding to the other
- The thermocouples of each winding are R-type ones with copper (or brass) sheaths of 10mm length soldered at the ends of the wires

- ➔ There is a difference in the design of furnaces – 120°-segments or monobloc

8.2. How to build a Furnace

- Necessary equipment :
 - Engine lathe with tailstock
 - Small wooden plates at the tool holder
 - Winding core
 - Hose clamp with soft material underneath (i.e. rubber)
 - Twisting tool A
 - Twisting tool B
 - Bending tool
 - Assembling core (segmented design)

- Assembling tool (segmented design)
- Cementing tool (monobloc design)

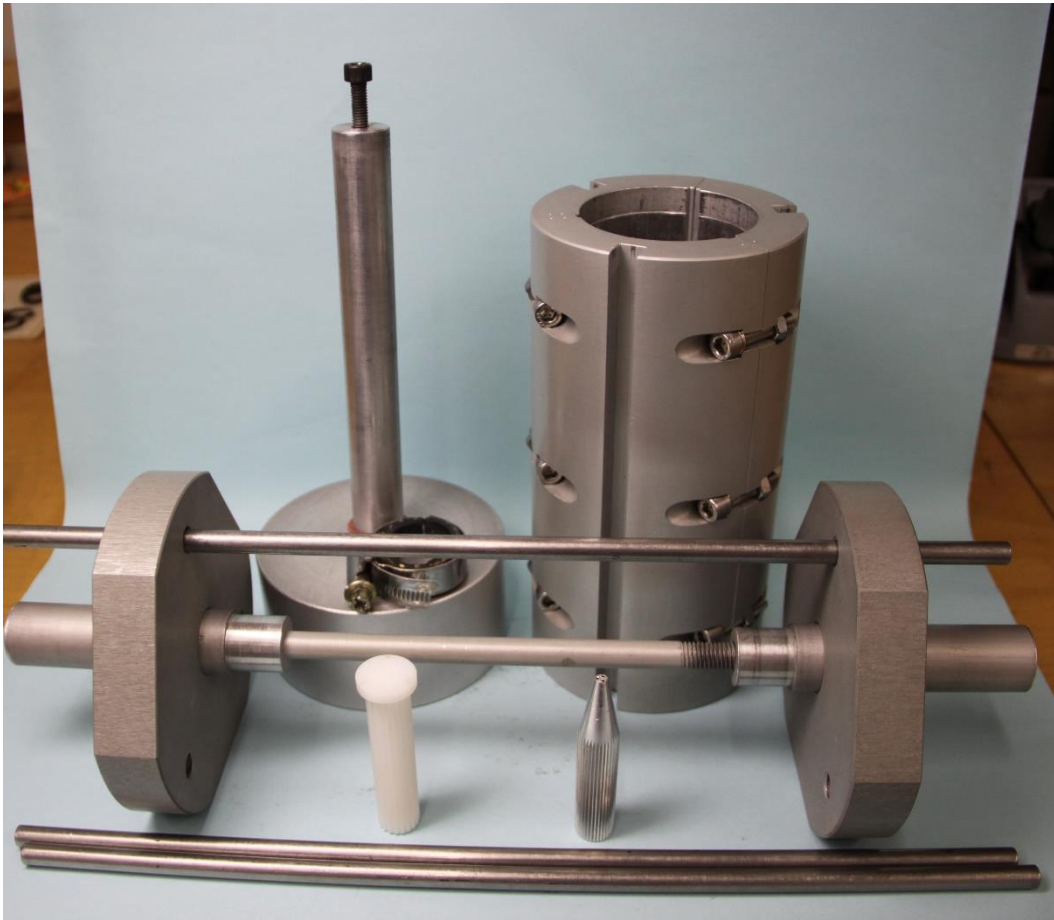

8.2.1. How to put windings on the furnace tube – segmented design

- Install the furnace tube on the winding core, the bottom end (shorter bigger diameter) shows to the clamping mandrel
- Span the winding core into the clutch of a lathe
- Use a permanent marker and mark the areas of the three windings with circumferential lines and the angle of their leads with axial lines at the furnace tube as shown in the following picture and drawing
- Some furnace tubes have three thin flanges of a slightly bigger diameter (27 mm) to separate the windings (not shown in the following picture and drawing, however, visible in some photos) – these flanges correspond to the circumferential lines of an ordinary furnace tube

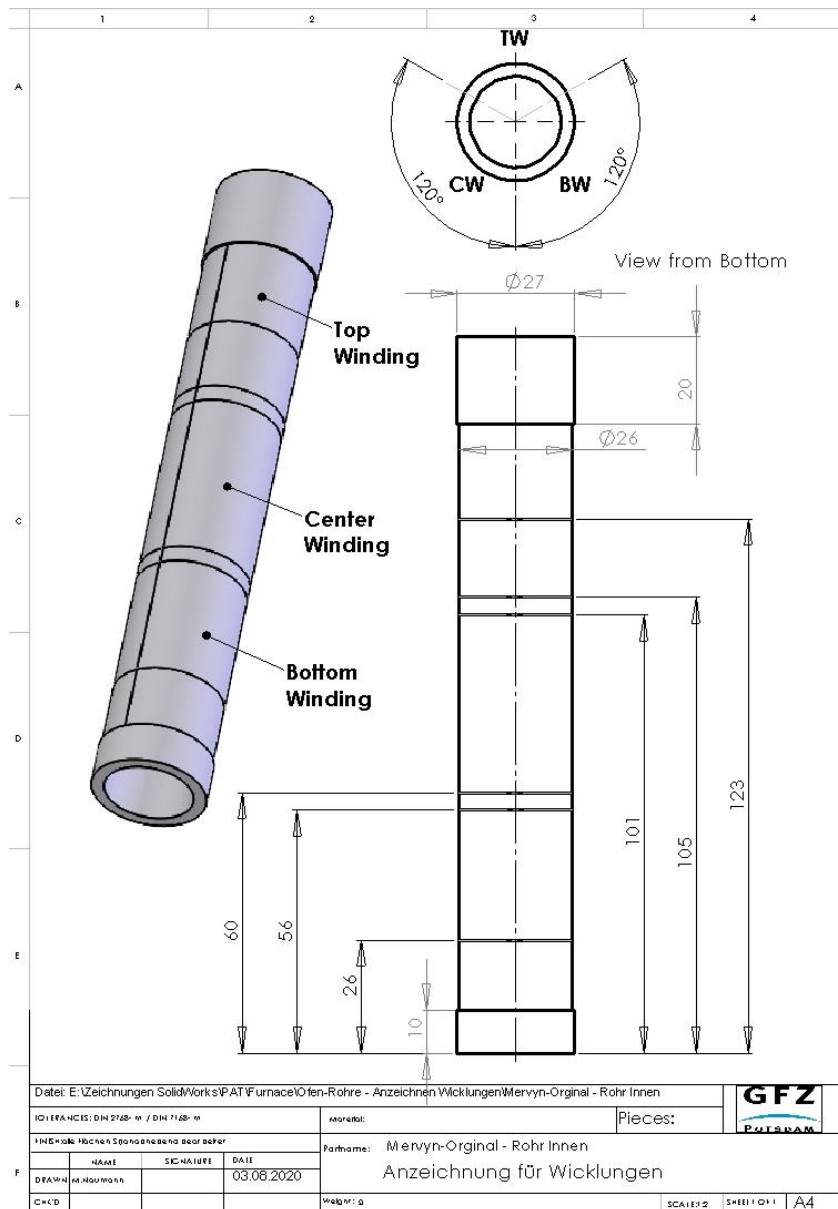
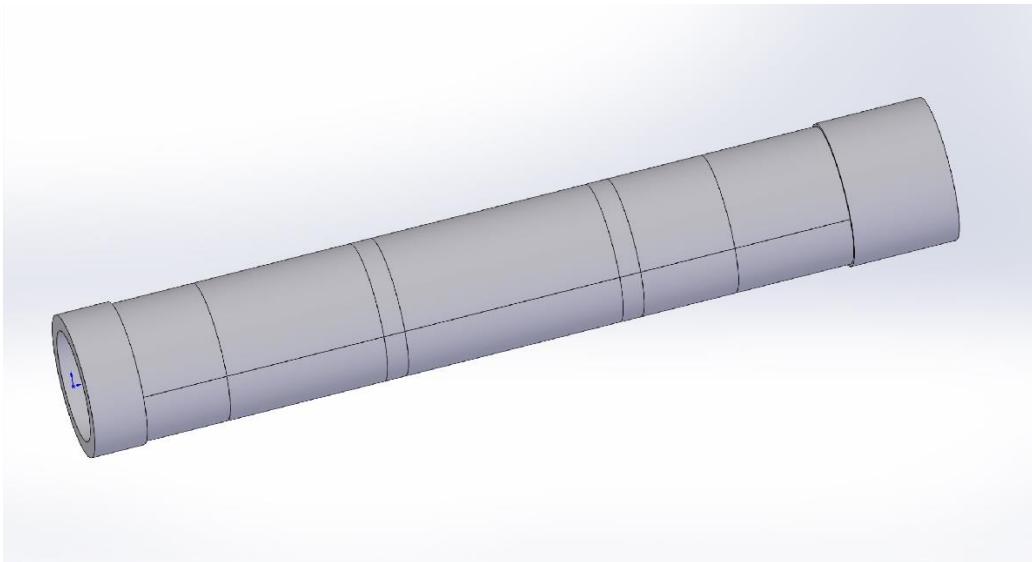

- Span the winding core of the furnace tube into the chuck of an engine lathe, fix the other end of the core with the tailstock
- Start with the **top winding** and repeat the following steps for each winding
- Take a molybdenum wire of a convenient length and fix it with a hose clamp at the tube at the circumferential line of the bottom end and the axial line of this winding (most of the following photos are of the bottom winding on a furnace tube with flanges with already finished center and top winding, some photos are of the top winding)
- The length of the wires is :
 - **Top : 2200 mm**
 - **Center : 4000 mm**
 - **Bottom : 3000 mm**

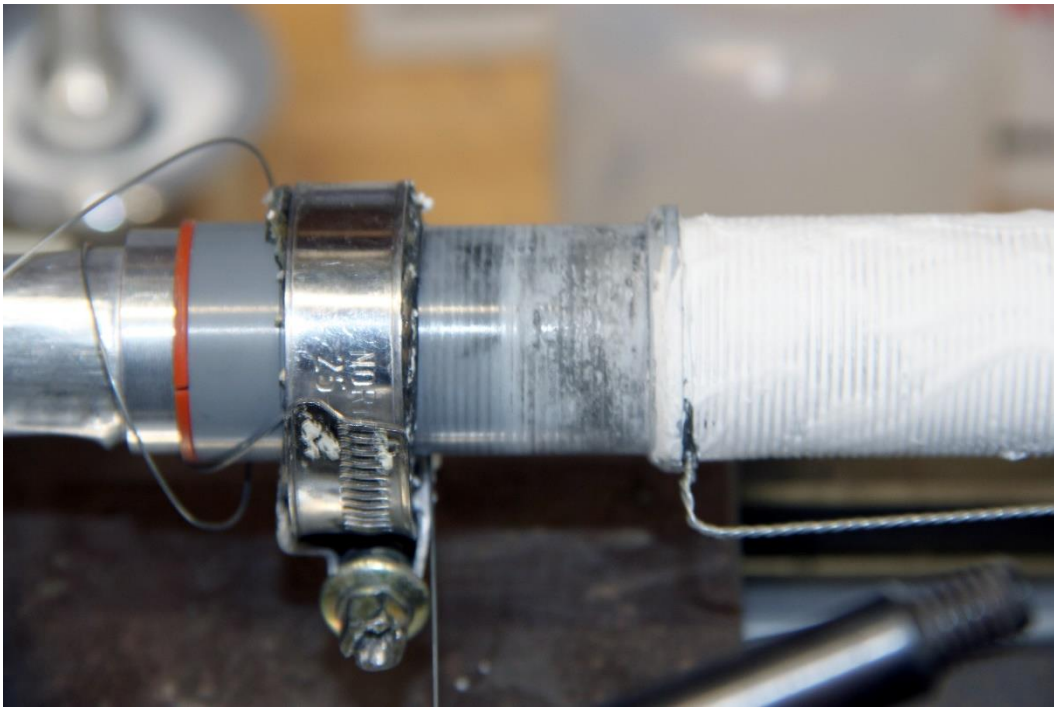

molybdenum wire fixed with a hose clamp at the tube

- Turn this winding-wire around the furnace tube ones and lead it under the tube to the tool holder
- Clamp the winding-wire in between two hard-wooden plates in the tool holder keeping the wire under a certain slight tension, the clamping force has to be big enough to hold tension and small enough that it allows gliding of the wire through the hard-wooden plates



clamped winding-wire between two hard-wooden plates in the tool holder



- Set the lead screw of the lathe to a slope of **1,25**
- Turn the lathe chuck manually and slowly in order to wind the wire around the furnace tube

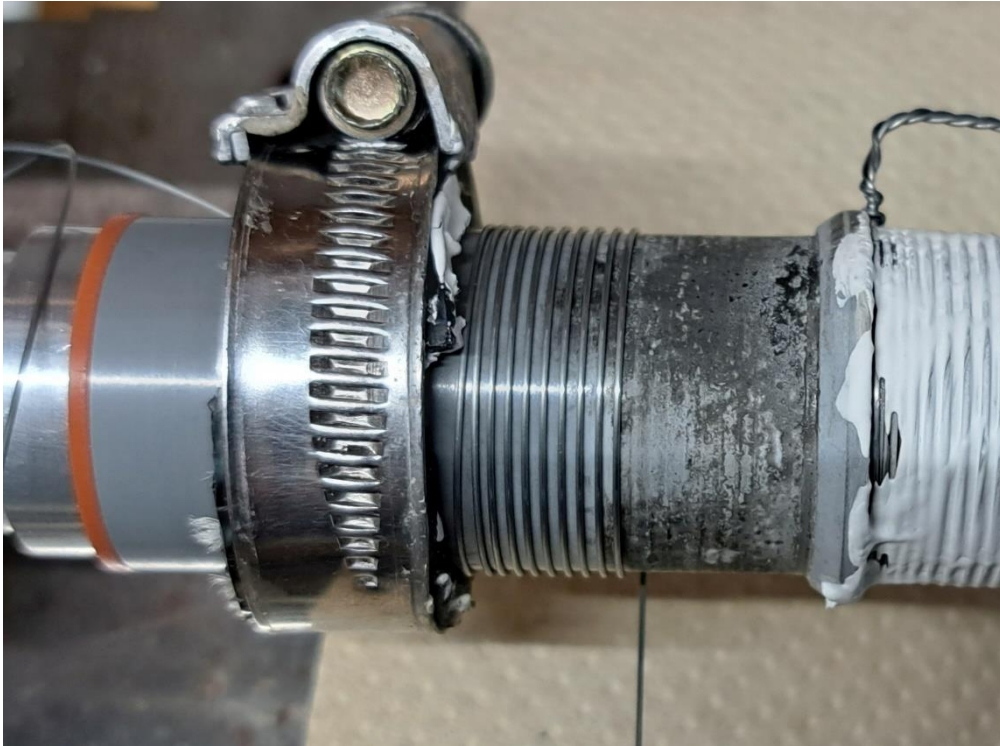

- After implementing the desired turns stop at the circumferential line of the top end of this winding with its axial line showing vertical up
- Increase the clamping force at the tool holder to fix the wire completely
- Clamp the tailstock sufficient

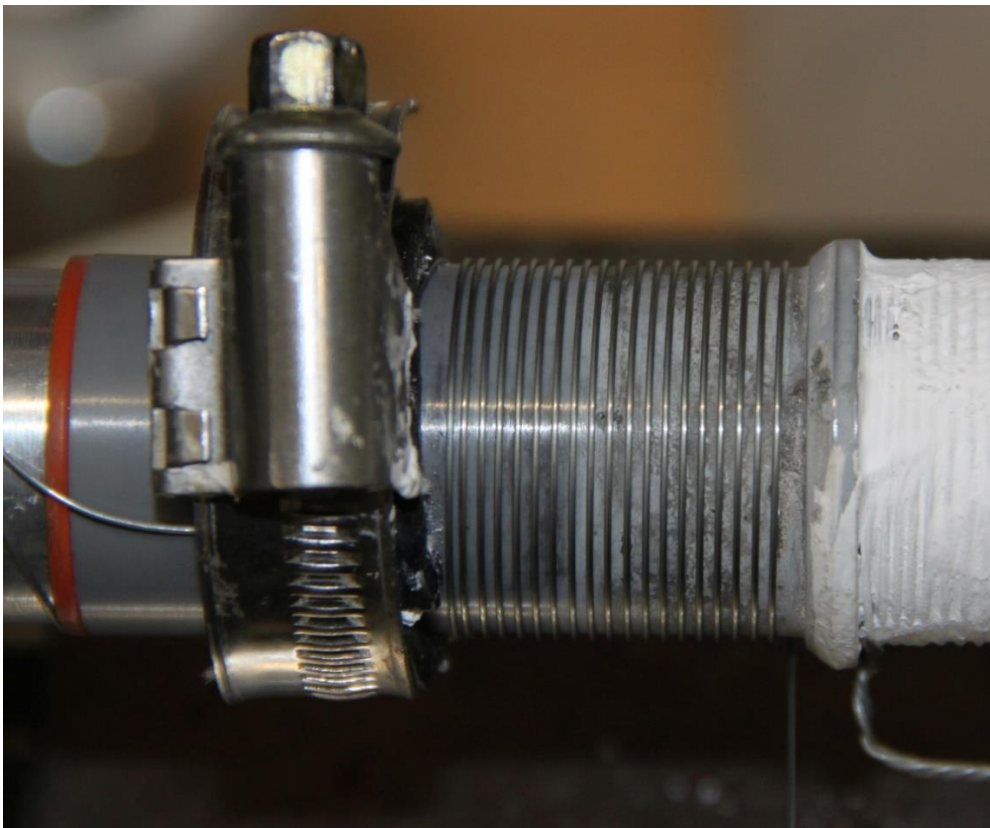

- Take another molybdenum wire of about **500 mm** length and make a loop of it around the tube over the winding-wire next to the hose clamp, both ends should have the same length roughly
- Twist this additional wire clockwise with the appropriate twisting tool A two/three turns tight at the tube to fix the winding-wire, **make sure that its ends lead in radial direction at its axial line**

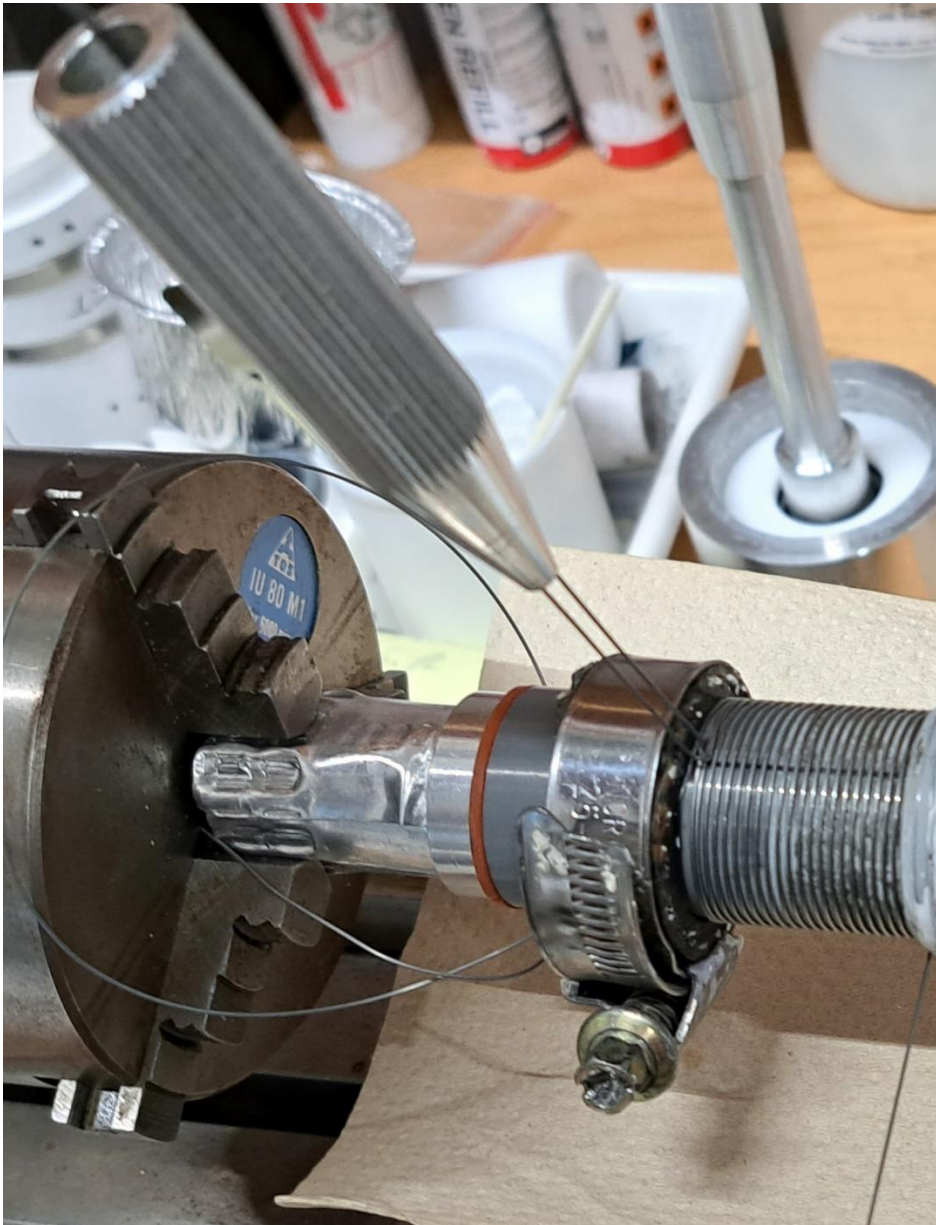

molybdenum wire loop around the tube and twisting tool A

- Take a second molybdenum wire of about **500 mm** length and make a loop of it around the tube over the winding-wire next to the still clamped wire in the tool holder, both ends should have the same length roughly
- Twist this additional wire clockwise with the appropriate twisting tool A two/three turns tight at the tube to fix the winding-wire, **make sure that its ends lead in radial**

direction at its axial line (the following photos are of the top or of the bottom winding respectively)

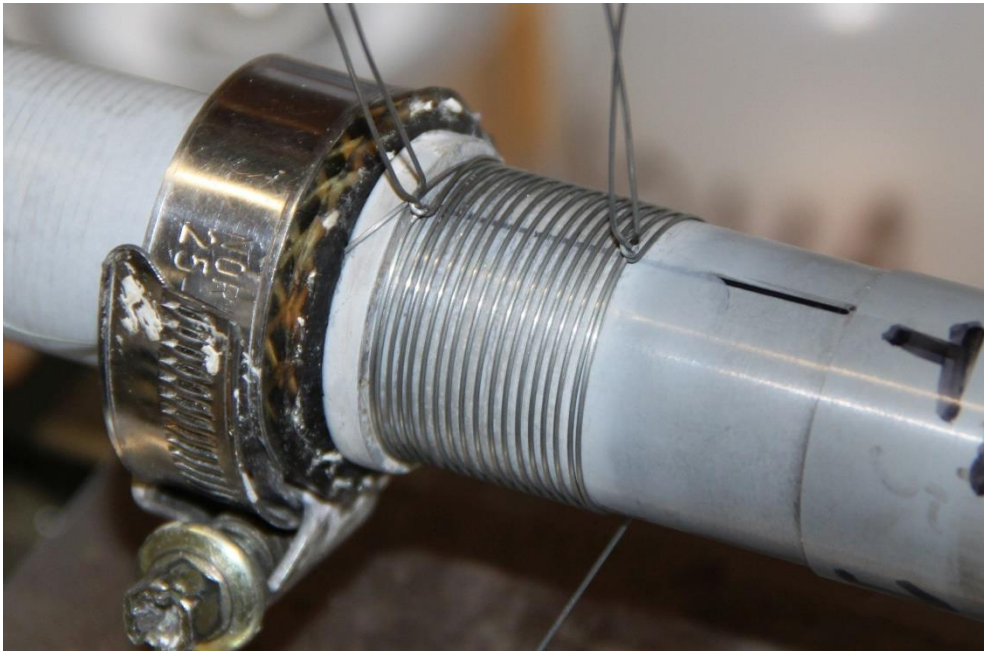

wire winding finished and wire loops around the tube

- Cement the winding with a thin layer of Ceramabond 569

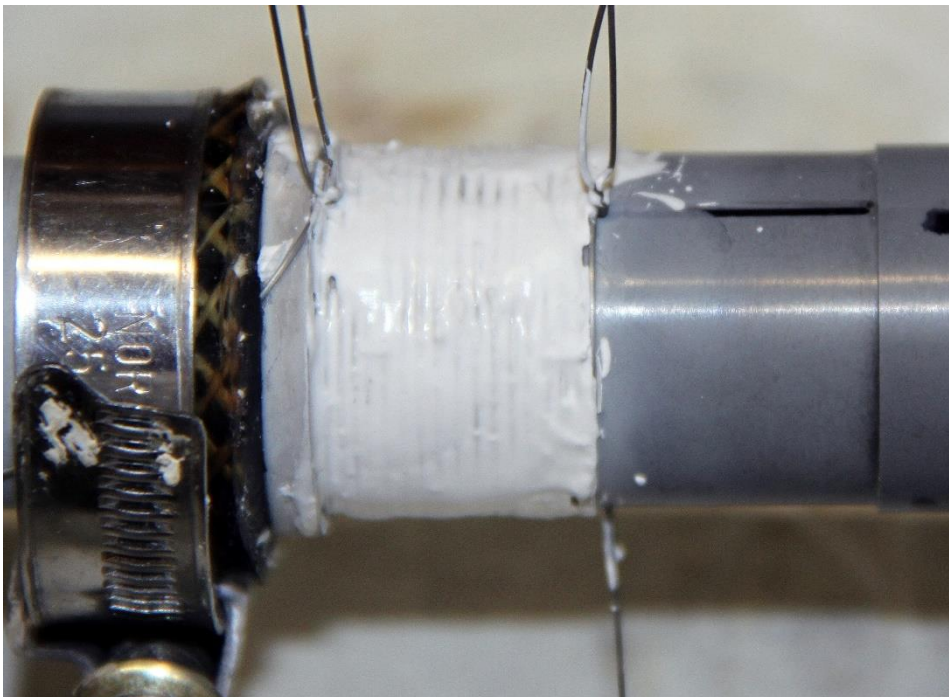

cemented wire winding at the tube

- Leave it several hours (i.e. overnight) in order to dry and harden the cement

- Loose the clamp of the tool holder and take this end of the winding-wire carefully out of it, keep tension on the winding-wire
- Twist this end of the winding-wire manually clockwise twice around the other two wires
- Twist all three wires together clockwise with the appropriate twisting tool B, at least **150...200 mm**

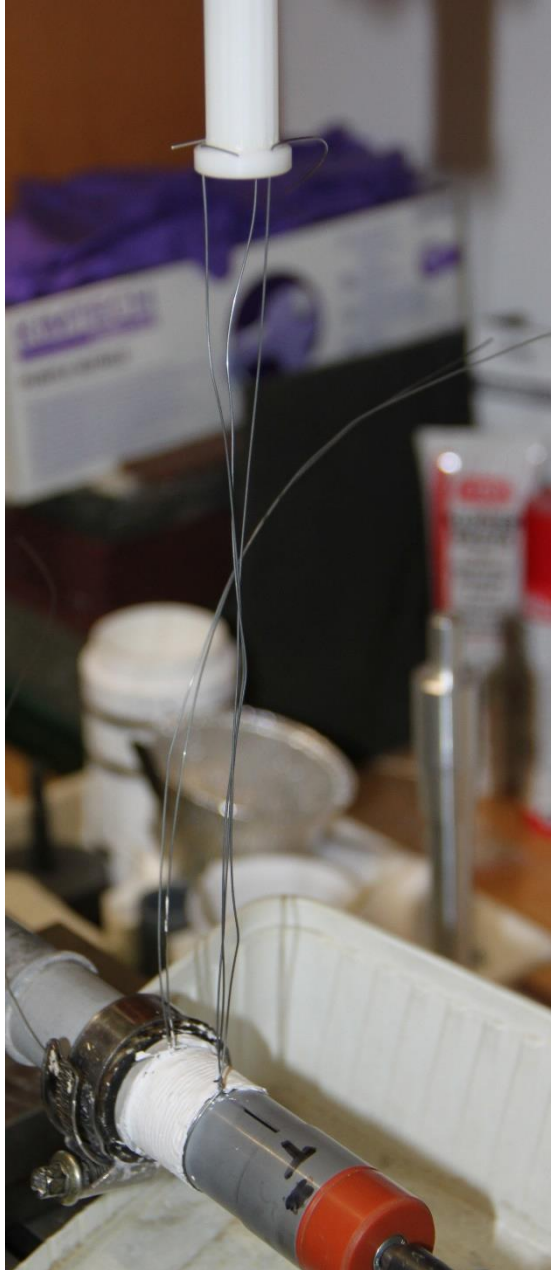

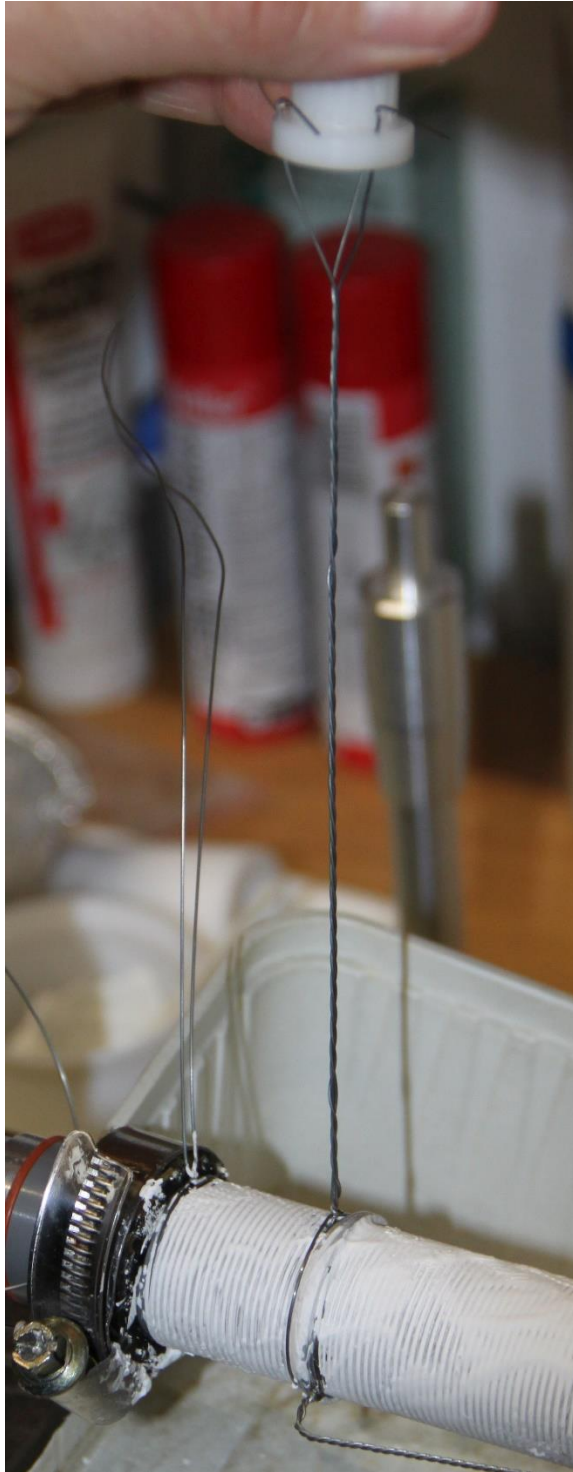

twisted wires (winding and loop) with twisting tool B

- Bend the twisted wires of the top end of the winding in a right angle leading to the top end of the furnace tube making sure that this twisted wires run parallel to the axis of the tube with a distance of about **4 mm** to the surface of the cement

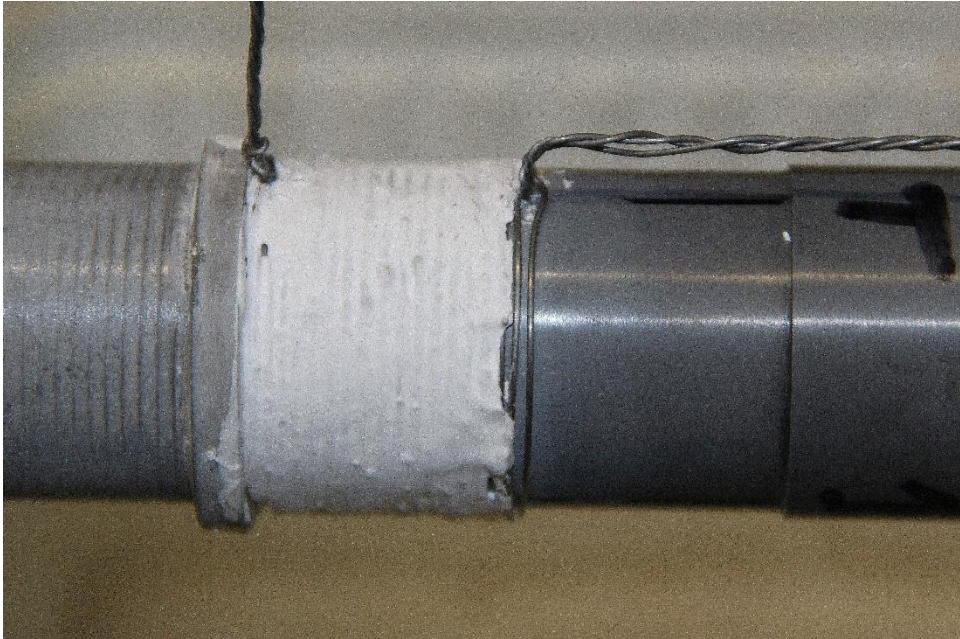

- Open the hose clamp and release this end of the winding-wire carefully, keep tension on the winding-wire
- Twist this end of the winding-wire manually clockwise twice around the other two wires
- Twist all three wires together clockwise with the appropriate twisting tool B, at least **150...200 mm**
- Bend the twisted wires of the bottom of the winding in a right angle leading to the top end of the furnace tube making sure that this twisted wires run parallel to the axis of the tube with a distance of about **8 mm** to the surface of the cement

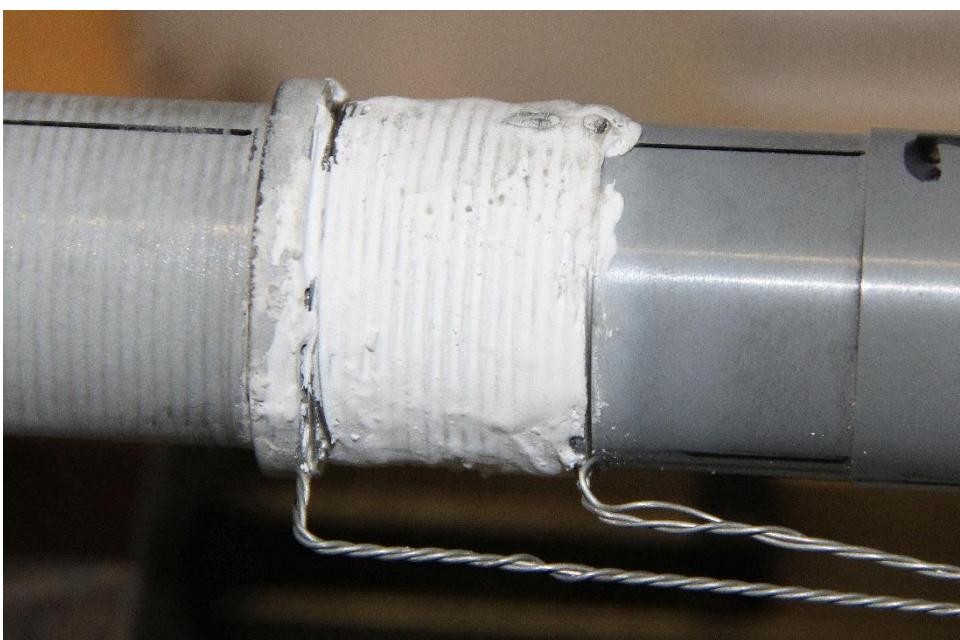

- Repeat all steps of spooling for the other two windings
- Repeat the bending for the other two windings with another molybdenum wire of about 500 mm length, **make sure that the twisted wires go along the lines of the angles for each winding reaching about 50 mm beyond the top end of the furnace tube**
- Complete the cementation of the windings with Ceramabond 569, if necessary
- **At the bottom winding the leads of Live and Ground may be swapped**
- **In that case the contacts of the bottom winding at the top of the furnace are swapped partly with the ones of the bottom thermocouple**
 - **Ordinary leads at the bottom winding (Live at top, Ground at bottom)**
 - **Live and Ground run in the same slit of the insulation segments to the top**
 - **Tube with flanges of bigger diameter for separating the windings**

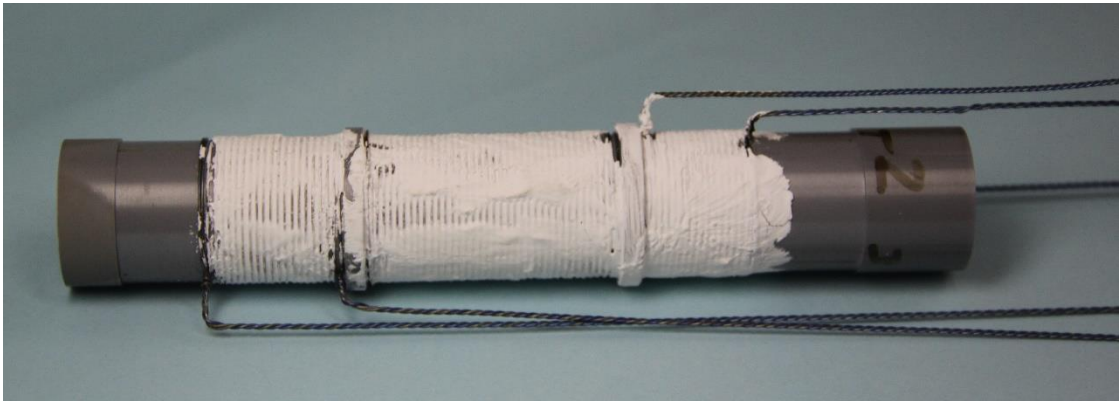

- **Swapped leads at the bottom winding (Ground at top, Live at bottom)**
- **Live runs alone in a slit of the insulation segments to the top, Ground runs in the same slit as the top winding**

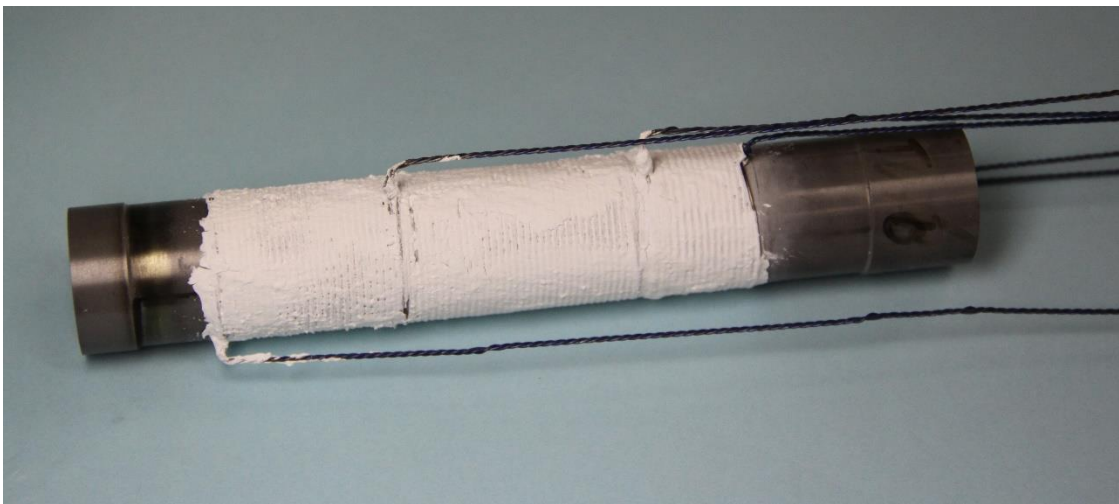

- Remove the winding core with the furnace tube of the chuck of the engine lathe
- Remove the winding core of the furnace tube

- Place the furnace tube into an oven with about 120°C for drying the ceramic cement completely

8.2.2. How to put windings on the furnace tube – monobloc design

- Install the furnace tube on the winding core, the top end (bigger diameter) shows to the clamping mandrel
- Span the winding core into the clutch of a lathe
- Use a permanent marker and mark the areas of the three windings with circumferential lines and the angle of their leads with axial lines at the furnace tube as shown in the following picture and drawing, **consider that the leads of each winding are not in the same angle, they are separated by 30°**

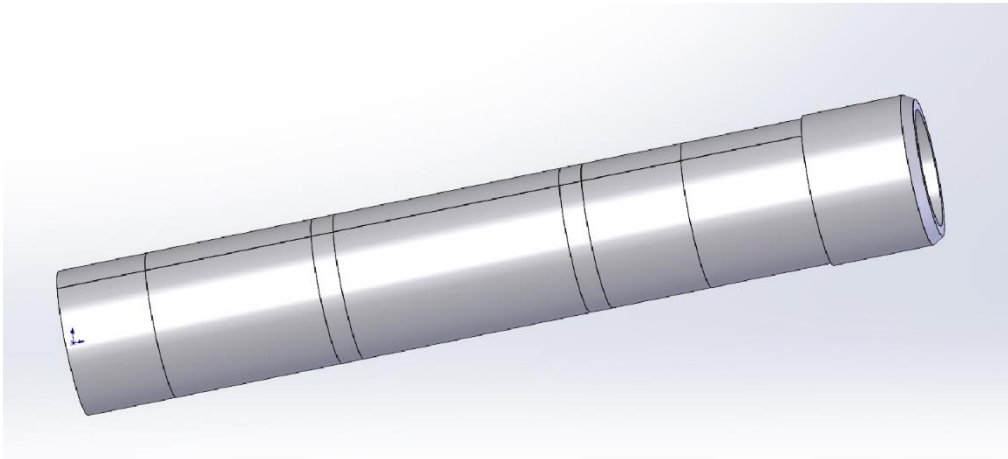

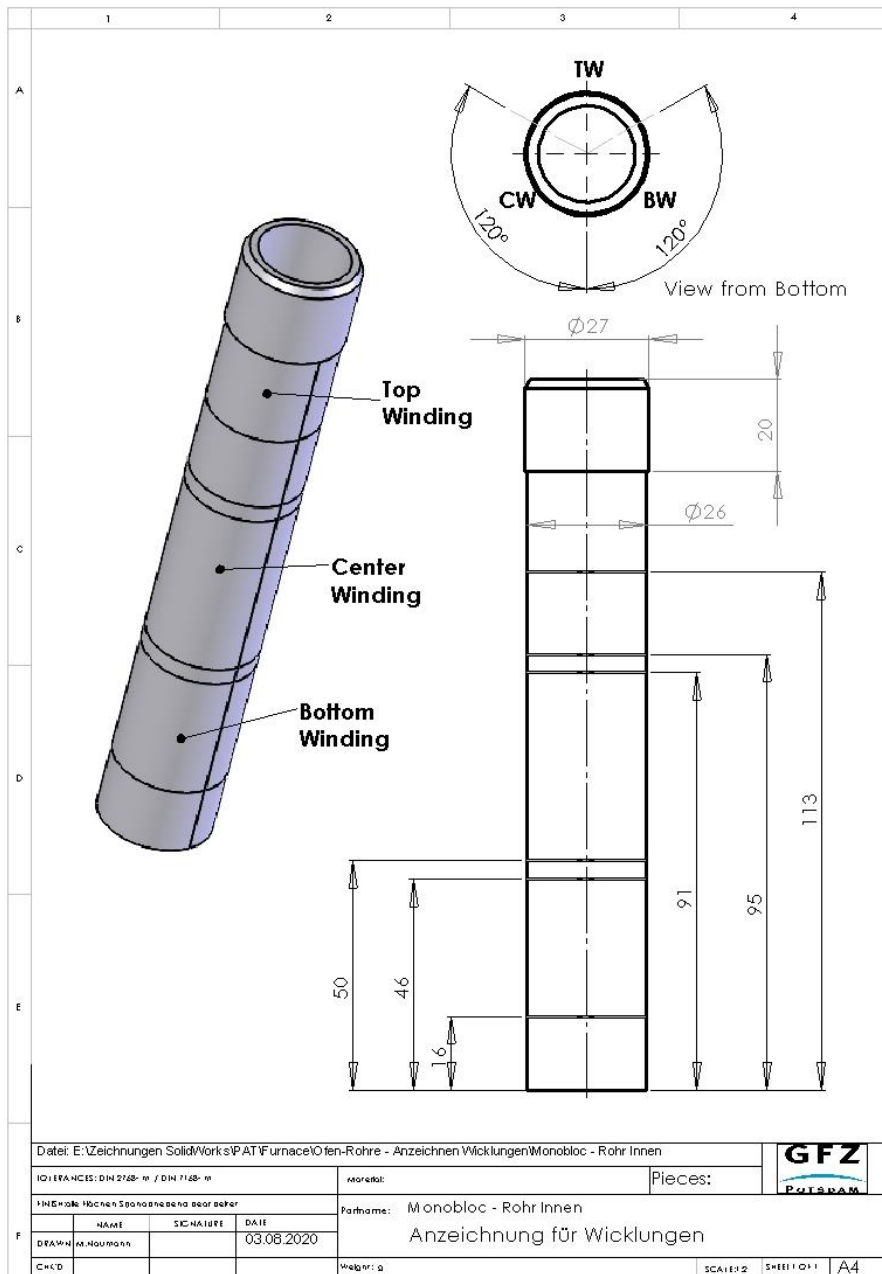

- Follow the steps described in the section 7.2.1. in principle, however, the twisted wires lead **to the bottom end** of the furnace tube
- Start with the **bottom winding** and repeat the following steps for each winding
- Take a molybdenum wire of a convenient length and fix it with a hose clamp at the tube at the circumferential line of the bottom end and the axial line of this winding
 - **Bottom : 3000 mm**
 - **Center : 4000 mm**
 - **Top : 3000 mm**
- Turn this winding-wire around the furnace tube ones and lead it under the tube to the tool holder

- Clamp the winding-wire in between two hard-wooden plates in the tool holder keeping the wire under a certain slight tension, the clamping force has to be big enough to hold tension and small enough that it allows gliding of the wire through the hard-wooden plates
- Set the lead screw of the lathe to a slope of **1,25**
- Turn the lathe chuck manually and slowly in order to wind the wire around the furnace tube
- After implementing the desired turns stop at the circumferential line of the top end of this winding with its axial lines both showing almost vertical up
- Increase the clamping force at the tool holder to fix the wire completely
- Take another molybdenum wire of about **500 mm** length and make a loop of it around the tube on top of the winding-wire next to the hose clamp, both ends should have the same length roughly
- Twist this additional wire two/three turns tight at the tube to fix the winding-wire, **make sure that its ends lead in radial direction at the correct axial line**
- Repeat the same fixing of the winding-wire at the other end of the winding
- Cement the winding with a thin layer of Ceramabond 569
- Leave it several hours (i.e. overnight) in order to dry and harden the cement
- Open the hose clamp and release this end of the winding-wire carefully, keep tension on the winding-wire
- Twist this end of the winding-wire manually twice around the other two wires
- Twist all three wires together, least **150...200 mm**
- Loosen the clamp of the tool holder and take this end of the winding-wire carefully out of it, keep tension on the winding-wire
- Twist this end of the winding-wire manually twice around the other two wires
- Twist all three wires together, least **150...200 mm**
- Bend the twisted wires of the bottom end of the bottom winding in a right angle leading to the bottom end of the furnace tube making sure that this twisted wires run parallel to the axis of the tube with a distance of about **4 mm** to the surface of the cement
- Repeat this bending at the twisted wires of the top of the bottom winding making sure that this twisted wires run parallel to the axis of the tube with a distance of about **8 mm** to the surface of the cement
- Repeat all steps of spooling for the other two windings
- Repeat the bending for the other two windings with another molybdenum wire of about **500 mm** length, **make sure that the twisted wires go along the lines of the angles for each winding reaching about 50 mm beyond the top end of the furnace tube**
- Complete the cementation of the windings with Ceramabond 569, if necessary
- Remove the winding core with the furnace tube of the chuck of the engine lathe

- Remove the winding core of the furnace tube
- Place the furnace tube into an oven with about 120°C for drying the ceramic cement completely

8.2.3. How to assemble a furnace - segmented design

- Install the furnace tube on the assembling core together with the bottom and top steel piece of the furnace
- Make sure that the segment of the top thermocouple corresponds to the small punch mark at the top steel piece
- Make sure that the inner twisted wires lead through the corresponding bores at the top steel piece (marked as "+") and the outer ones are located outside this piece
- Place the assembling core with the furnace tube vertical in its support
- Bend the outer twisted ground wires of each winding (twice - first left, second right) to fit into the corresponding bores in the top steel plate (marked with "ground")
- In the case of swapped live and ground leads of the bottom winding bend the ground wire (twice – first right, second left) to correspond to the ground bore of the bottom thermocouple (this thermocouple is swapped as well and uses the ground bore of the bottom winding instead)
- **Following pictures :**
 - **ordinary leads of the bottom winding (live and ground leads are not swapped)**
 - **tube with flanges of bigger diameter (27 mm) to separate the windings**

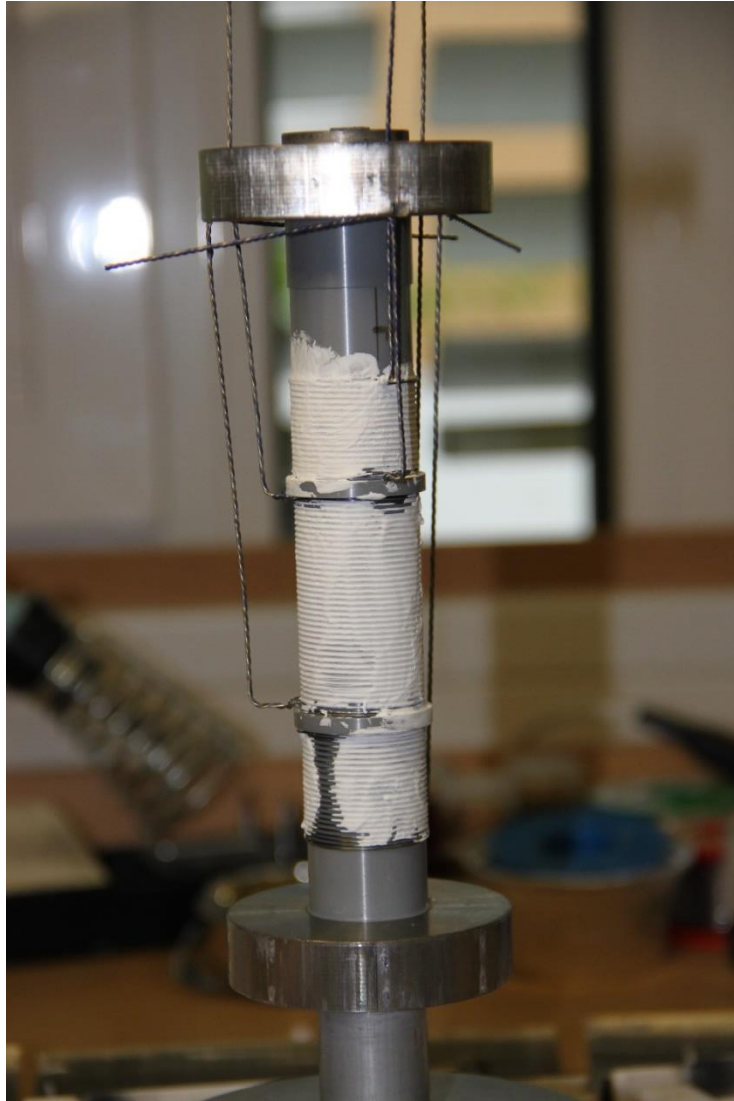

furnace tube on the assembling core with the bottom and top steel piece and with bent outer twisted ground wires

- Lift the top steel piece and lead the outer wires through the corresponding bores

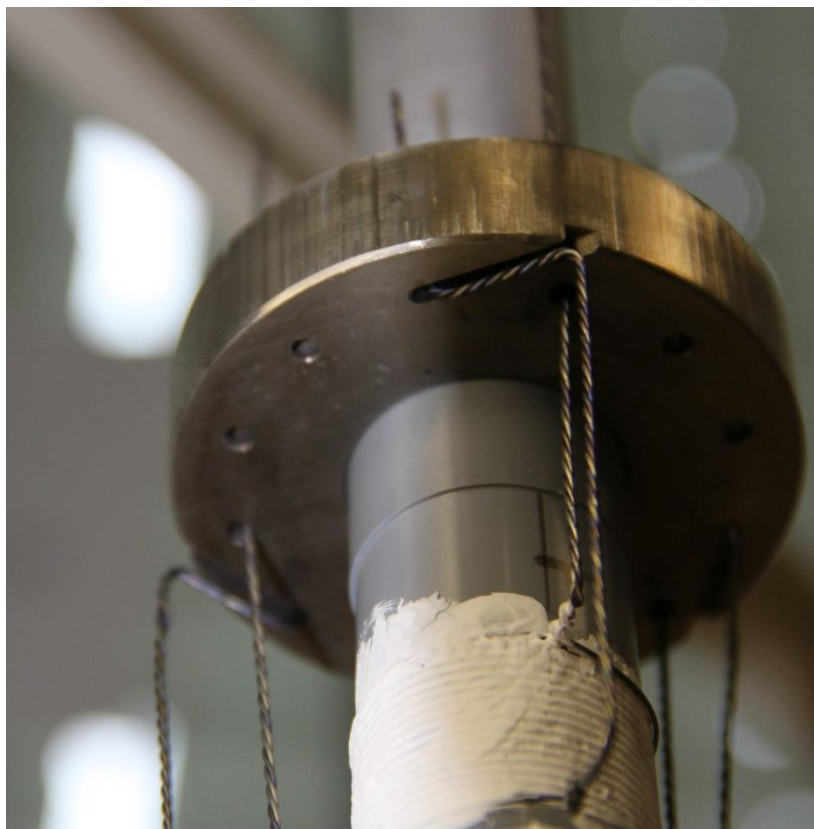
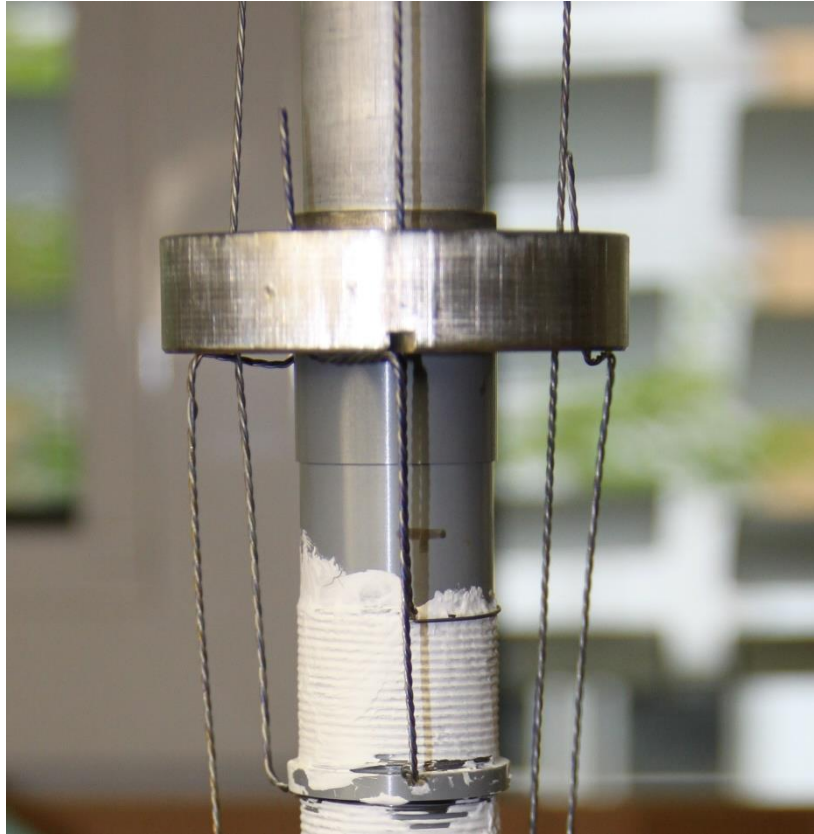

- Screw the top piece of the assembling core and tighten it slightly, use a kind of plastic washer (i.e. 1 mm thick) as a distance piece, if necessary

- Remove the assembling core of the vertical support and place it horizontal into the two supports of the assembling tool and install the other parts of the assembling tool, **the top of the furnace tube shows to the end of the assembling tool with a short offset at the inner diameter**
- Position the furnace tube inside the assembling tool in order to align the segments of the furnace tube and the assembling tool

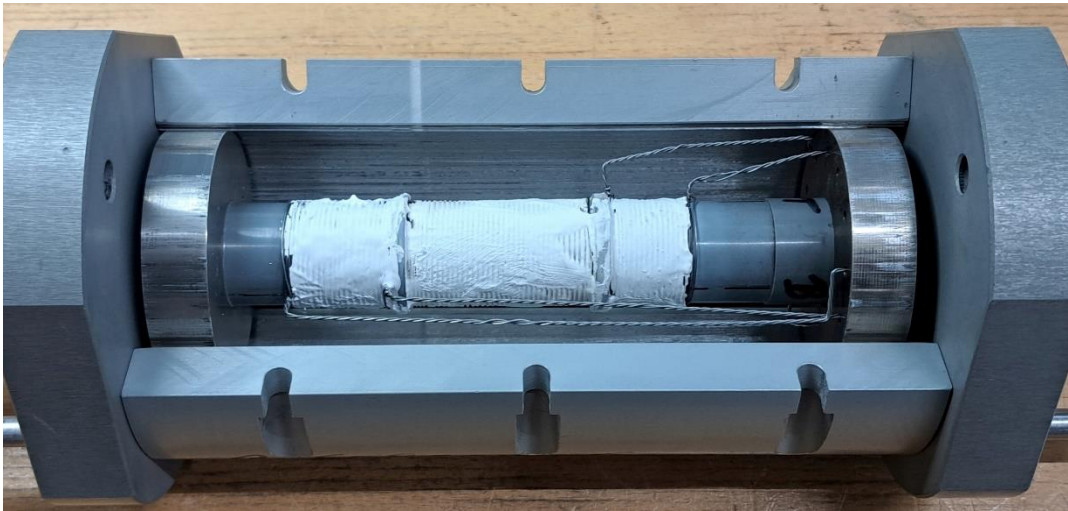

furnace tube inside the assembling tool

- Check the porous ceramic segment (SALI) for any gaps underneath

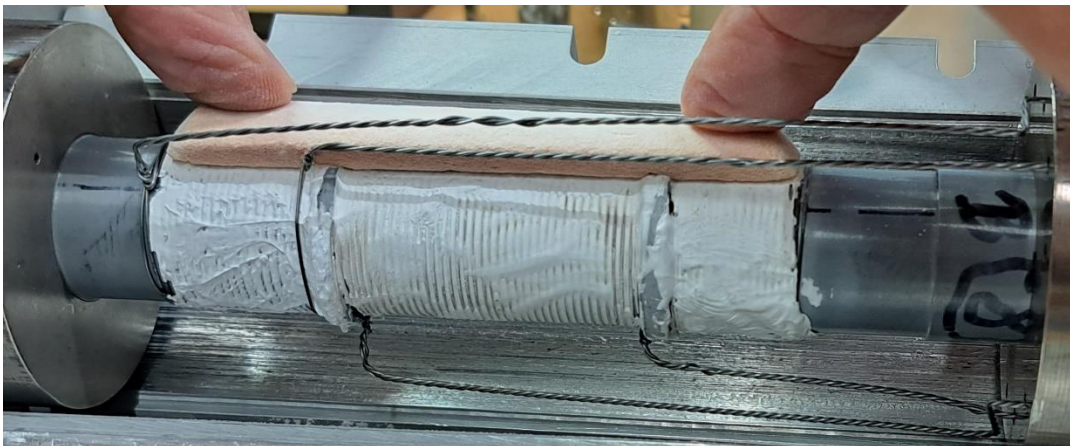

porous ceramic segment (SALI) at the furnace tube (for checking)

- Start to assemble the insulation at the segment of the bottom thermocouple
- Place a layer of alumina oxide paper (APA-2) at the furnace tube covering the whole length
- Place a porous ceramic segment (SALI) on this APA-2-layer covering all three windings



porous ceramic segment (SALI) with a layer of alumina oxide paper (APA-2) underneath

- Place another short layer of APA-2-paper on the SALI-segment reaching about 10mm further to each end of the furnace tube
- Place the top and the bottom zirconia oxide segments (PSZ) on the first and second APA-2-layer with the SALI-segment in between

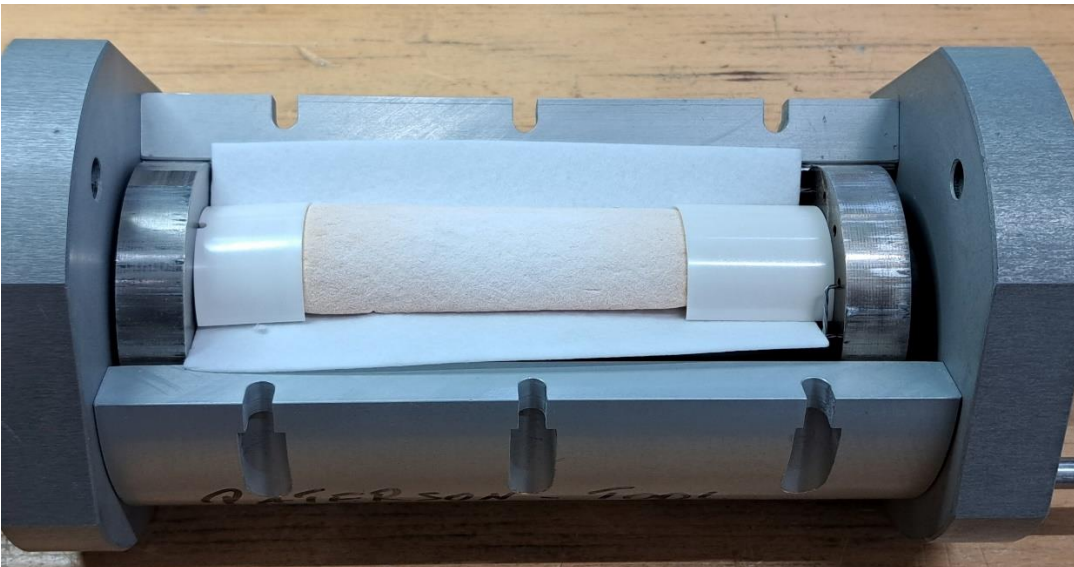

porous ceramic segment (SALI) alumina oxide paper (APA-2) and zirconia oxide segments (PSZ)

- Place another even shorter APA-2-layer on both gaps between the SALI-segment and the PSZ-segments (in addition some APA-2-paper at the ends only)

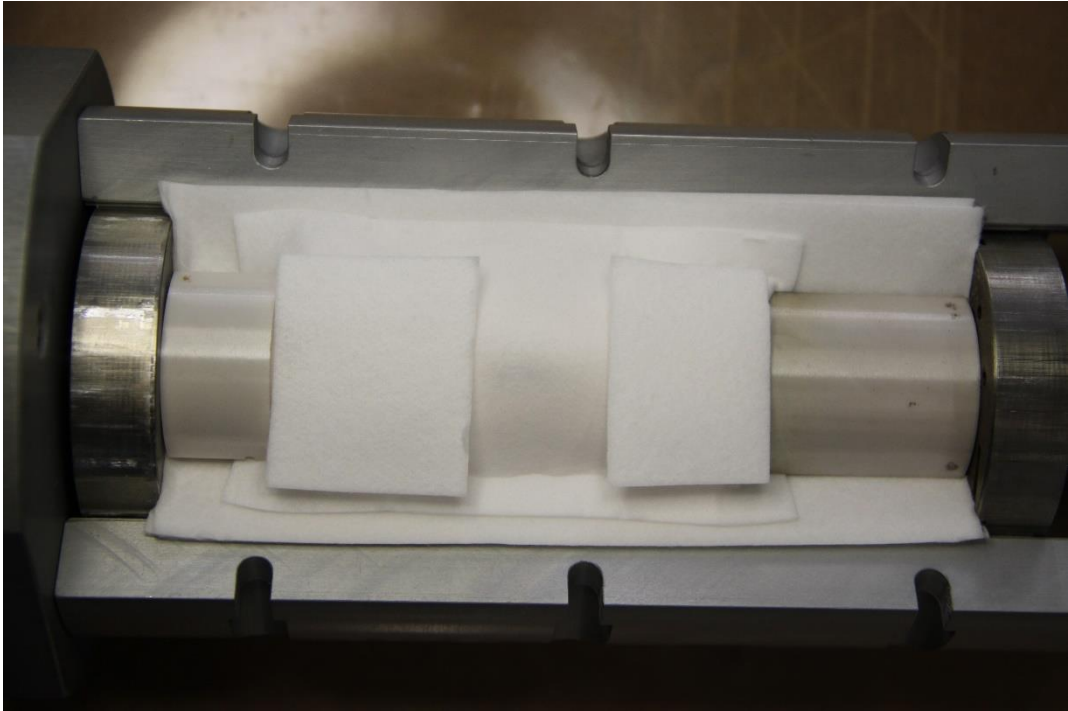

two layers of alumina oxide paper (APA-2) on top of the SALI-segment

- Place the big PSZ-segment on top of all, untighten the assembling core a bit if necessary

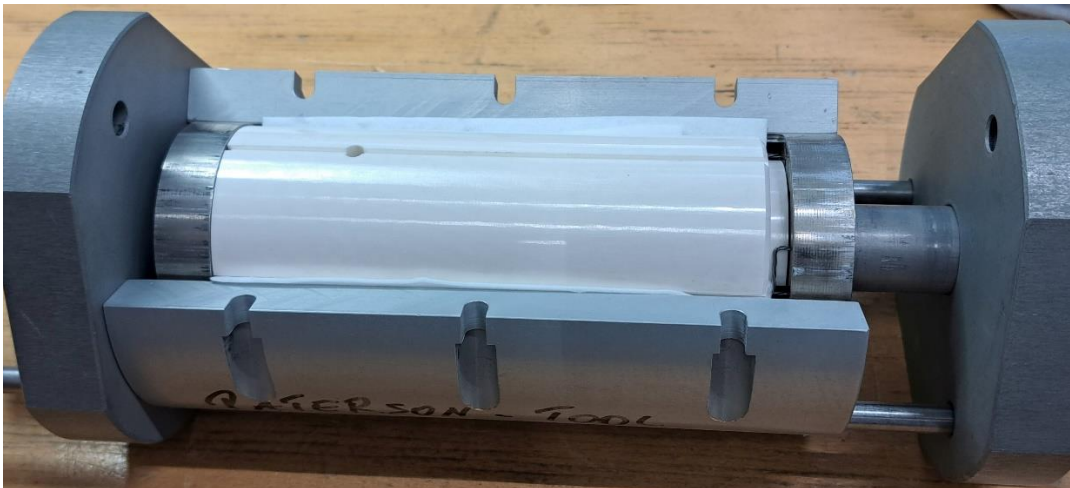

big PSZ-segment on top of all

- Punch with a piece of twisted wire a small bore into the SALI-segment through the bore of the PSZ-segment

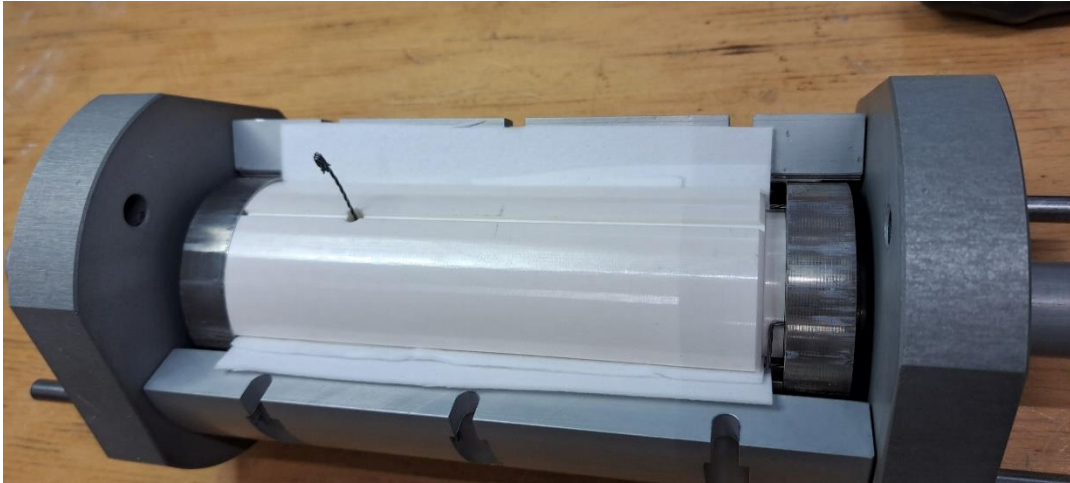

- Insert the bottom thermocouple wires through the bores in the top steel plate and push it into the groove and the bore of the big PSZ-segment, **make sure that there is no contact of the wires to ground**

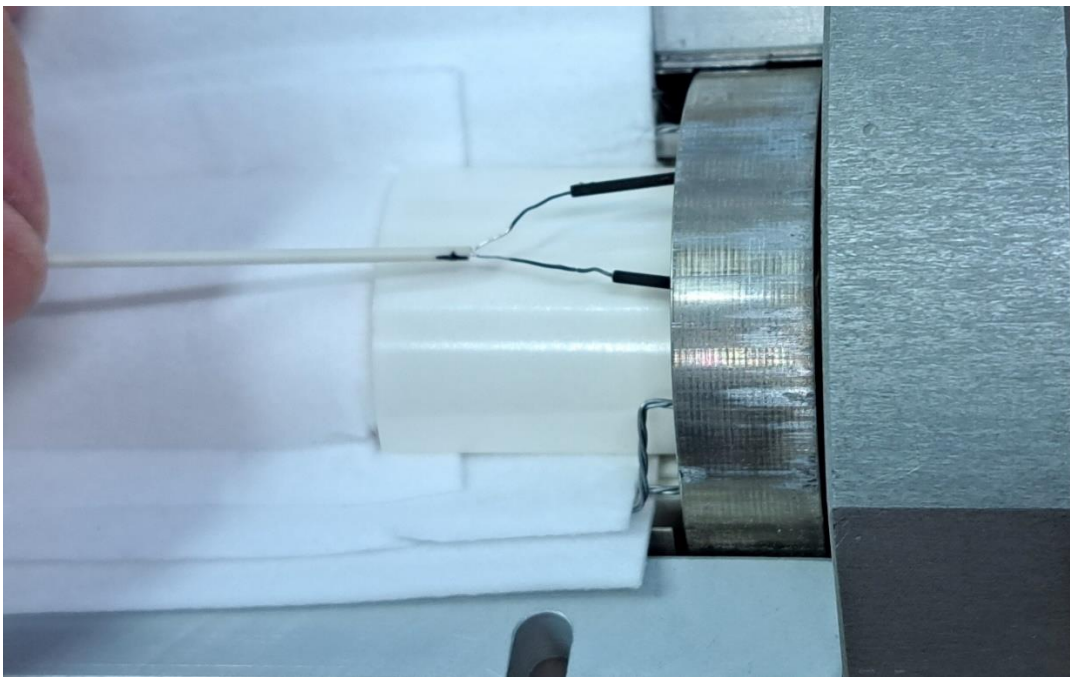

thermocouple wires through the bores in the top steel plate

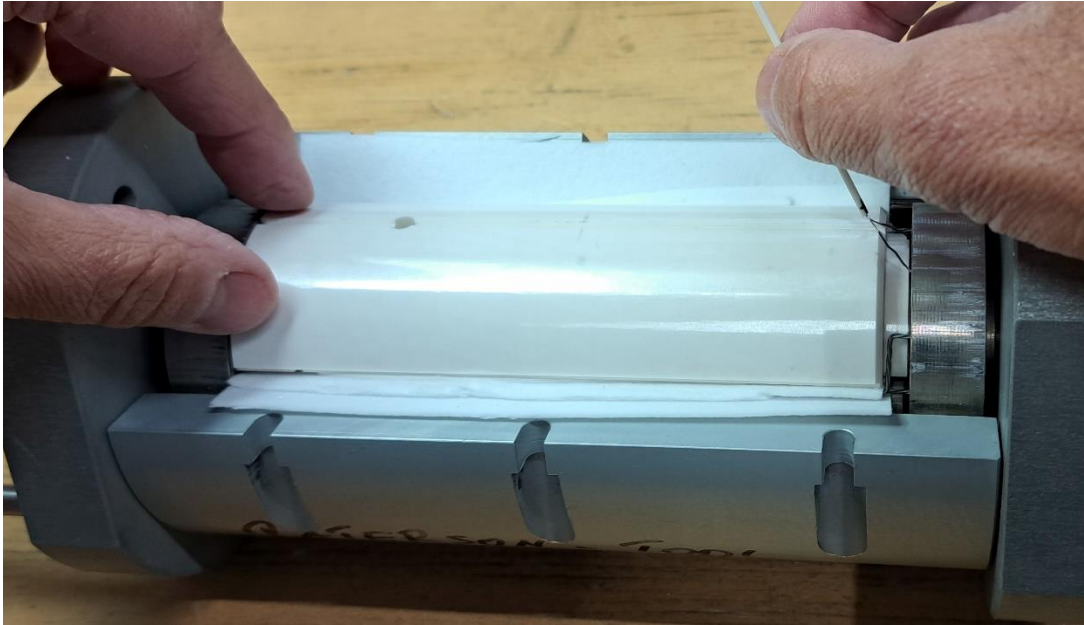

thermocouple installed completely

- Place another layer of APA-2-paper on the big PSZ-segment covering all the length and all the angle of this segment

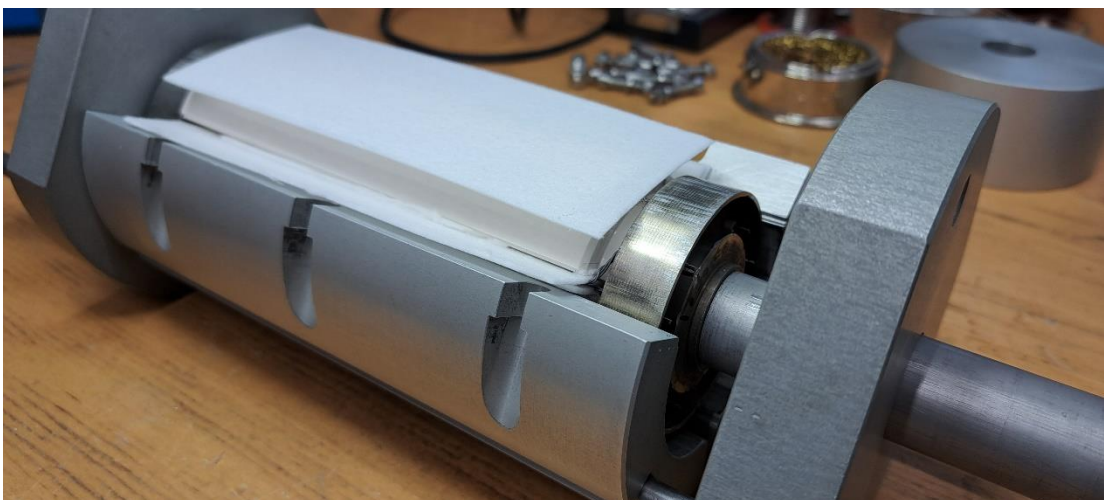

- Place the steel sheet on the APA-2-layer

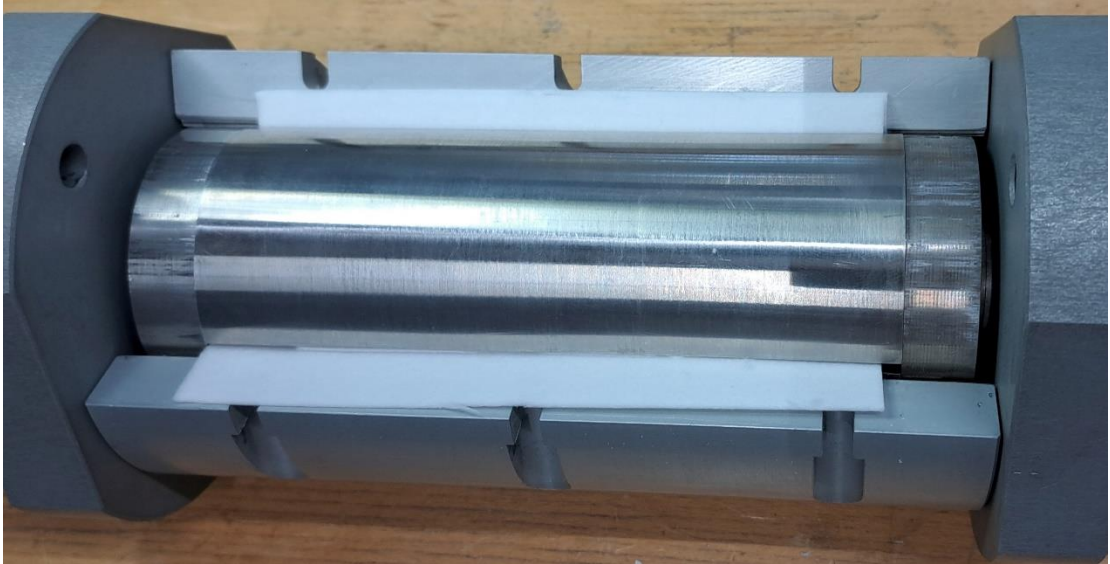

a third layer of APA-2-paper on top of the big PSZ-segment and a steel sheet

- Close the assembling tool with the aluminum segment and lock it with a rod inside the groove leading through corresponding bores inside the aluminum end pieces
- Repeat all steps with the other two segments (photo of last segment open)

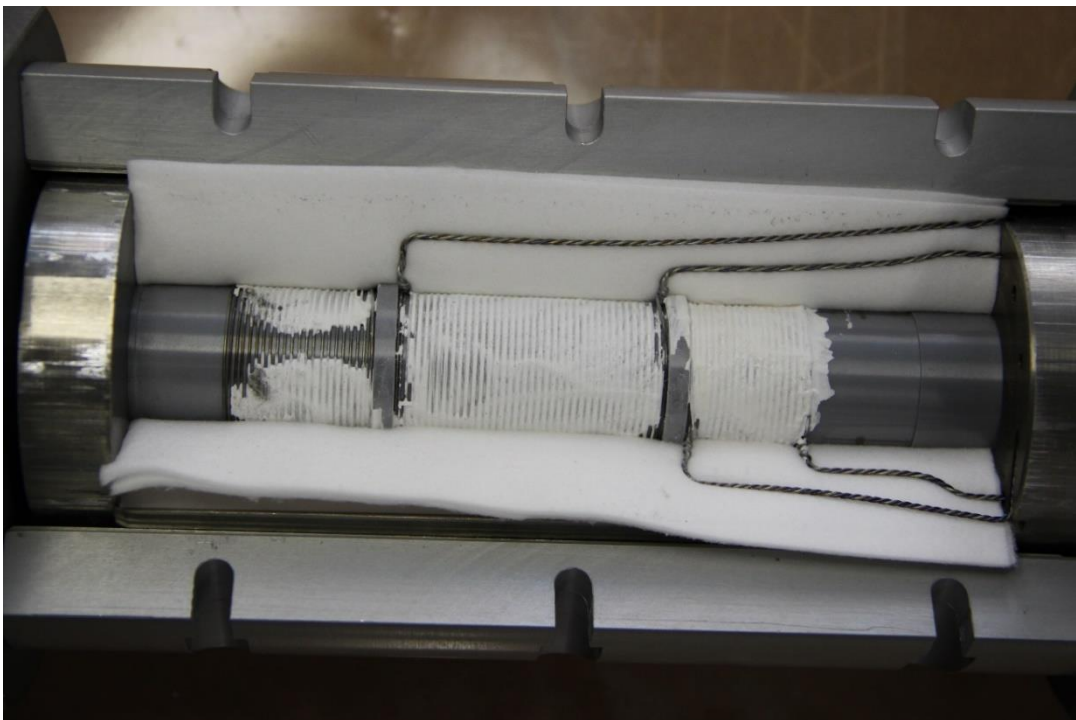

- Install the three screws at the center into the grooves of the assembling tool and tighten them step by step one after the other, **make sure to remain symmetric**



- Install the other six screws and tighten those as well, **make sure that all axial gaps between the segments have almost the same thickness with parallel edges**
- Remove the rods of the segments
- Remove the assembling core
- Place the outer steel can of the furnace into the assembling tool sitting on the offset of the inner diameter



- Place both upside down in the frame of a small hydraulic press
- Place a distance piece (aluminum) on top of the bottom piece of the furnace

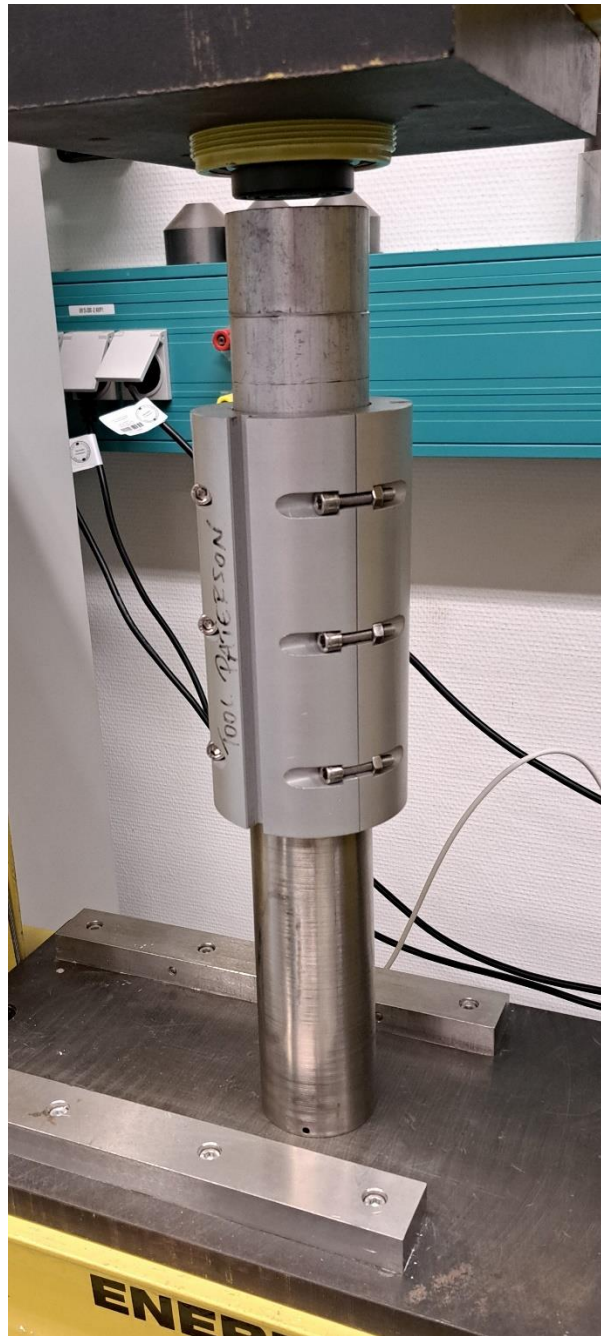

- Move the piston of the press down in order to push the assembled furnace out of the assembling tool into the outer steel can, **be carefully with the load, the furnace should move easily, if not untighten the screws next to the outer can a bit**
- Continue pushing the furnace out with the help of the other distance pieces, **tighten the other screws a bit if necessary**
- Stop pushing further if the top steel piece of the furnace reaches the small bores in the outer can

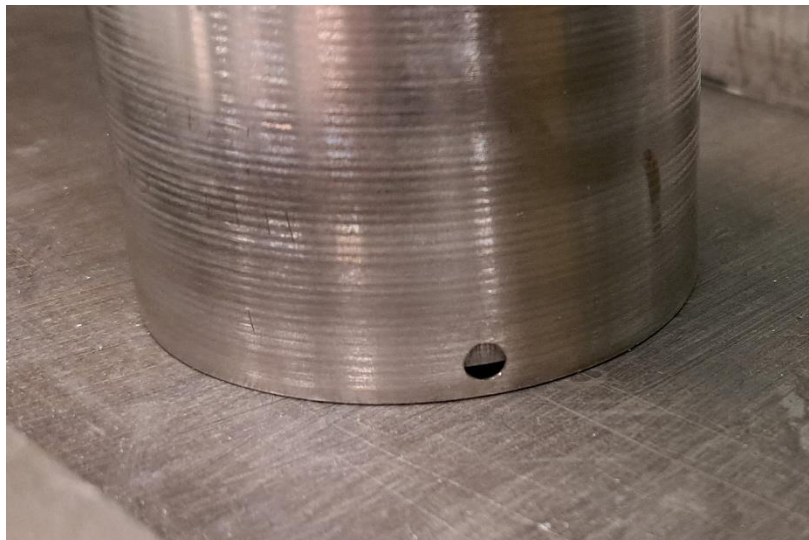

- Release the load of the press, move the piston up and remove the assembling tool with the furnace pushed out
- Push the furnace with the help of the hydraulic press to a position in the outer can that the edge of this can and the outer diameter of the bottom piece are almost the same

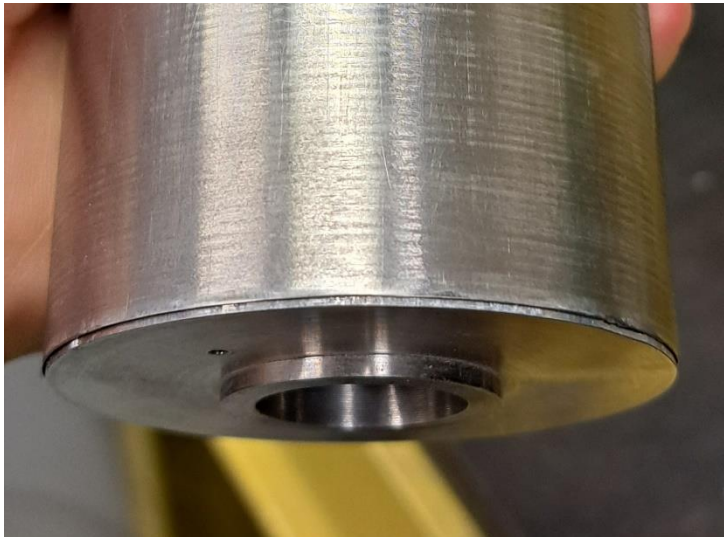

- Push short alumina oxide tubes of sufficient length over the twisted wires of all windings and all the thermocouple wires as well and insert those into the bores of the top steel piece in order to isolate those from ground (consider, there are designs of the top steel piece with very thin bores for the ground wires, no insulation fits in there, this is no disadvantage)



- Place PSZ-washers on all six thermocouple wires and the three twisted wires (Live +) of the windings in order to isolate the following sockets from ground
- Place brass washers on the three twisted wires (ground) of the windings

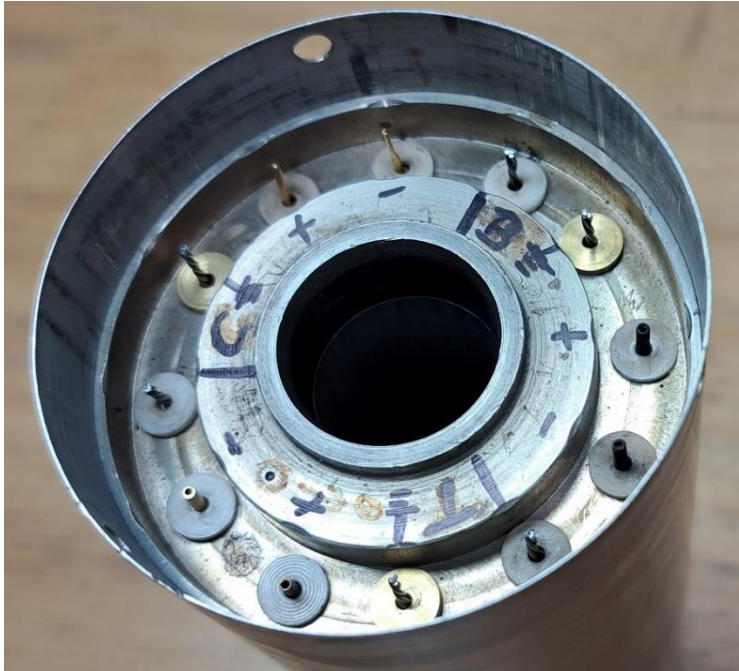

- Place all 12 furnace connector sockets on all wires and tighten them with a shortened Allen key

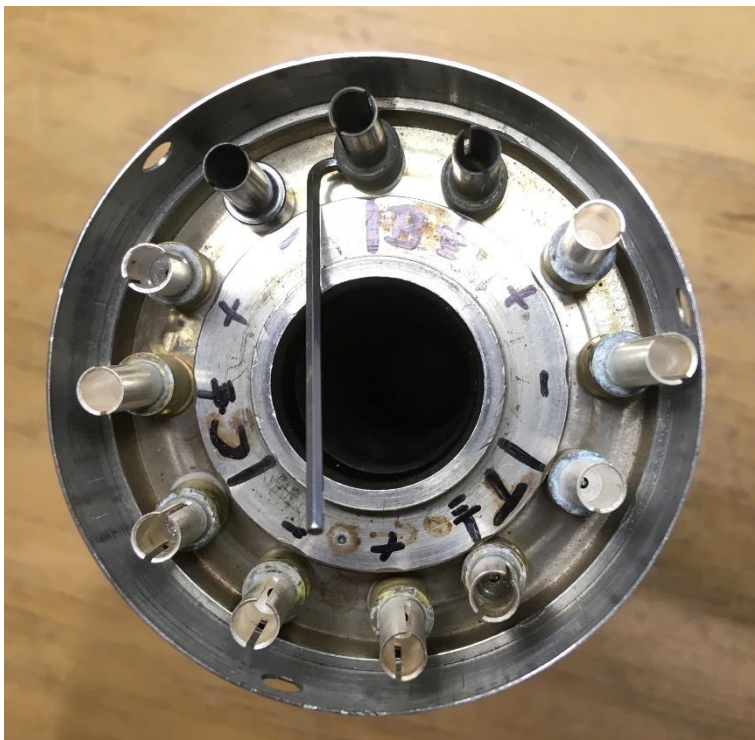

- Place the PSZ-ring over all sockets, **make sure that the additional small bore is located in between the two sockets of the top thermocouple**
- Place the top steel ring on top of the PSZ-ring
- Insert the three holding pins into the can and the top steel ring

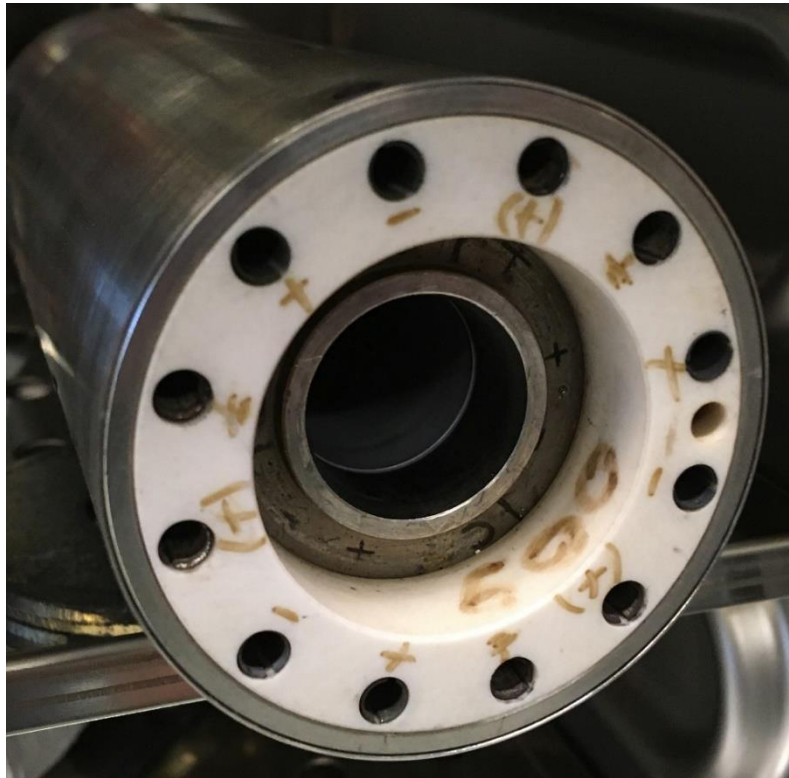

8.2.4. How to assemble a furnace - monobloc design

8.2.4.1. Assemble of the outer furnace part

- Prepare the outer ceramic cylinder (NZP-ceramic) with marks and notes of the windings and the thermocouples respectively corresponding to the drawing (view from top / cut B-B)

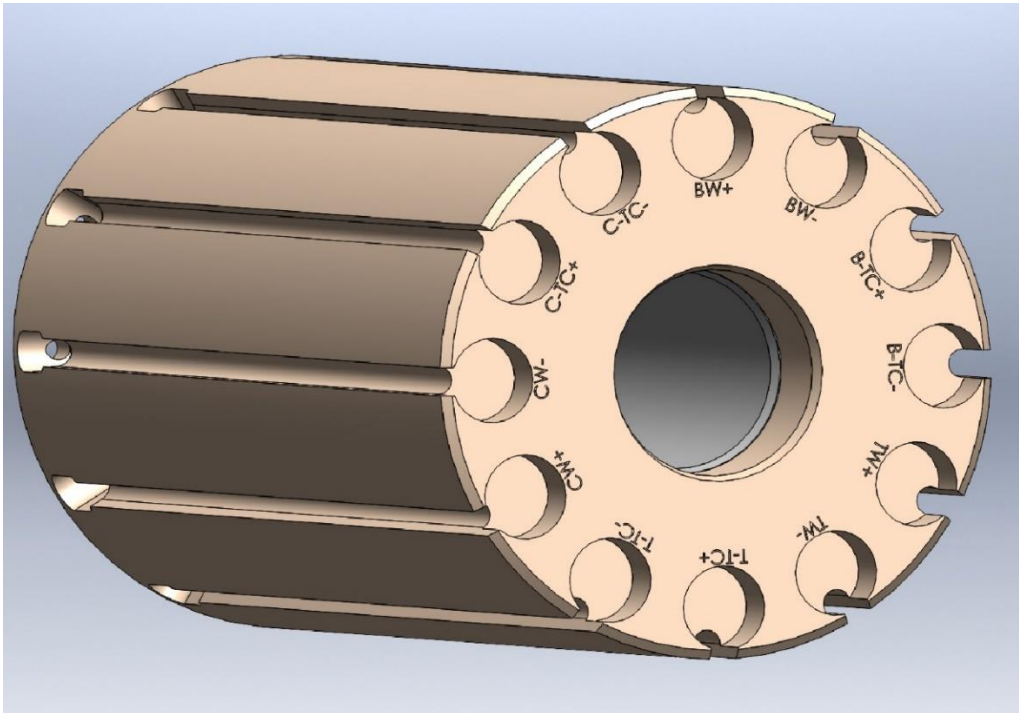

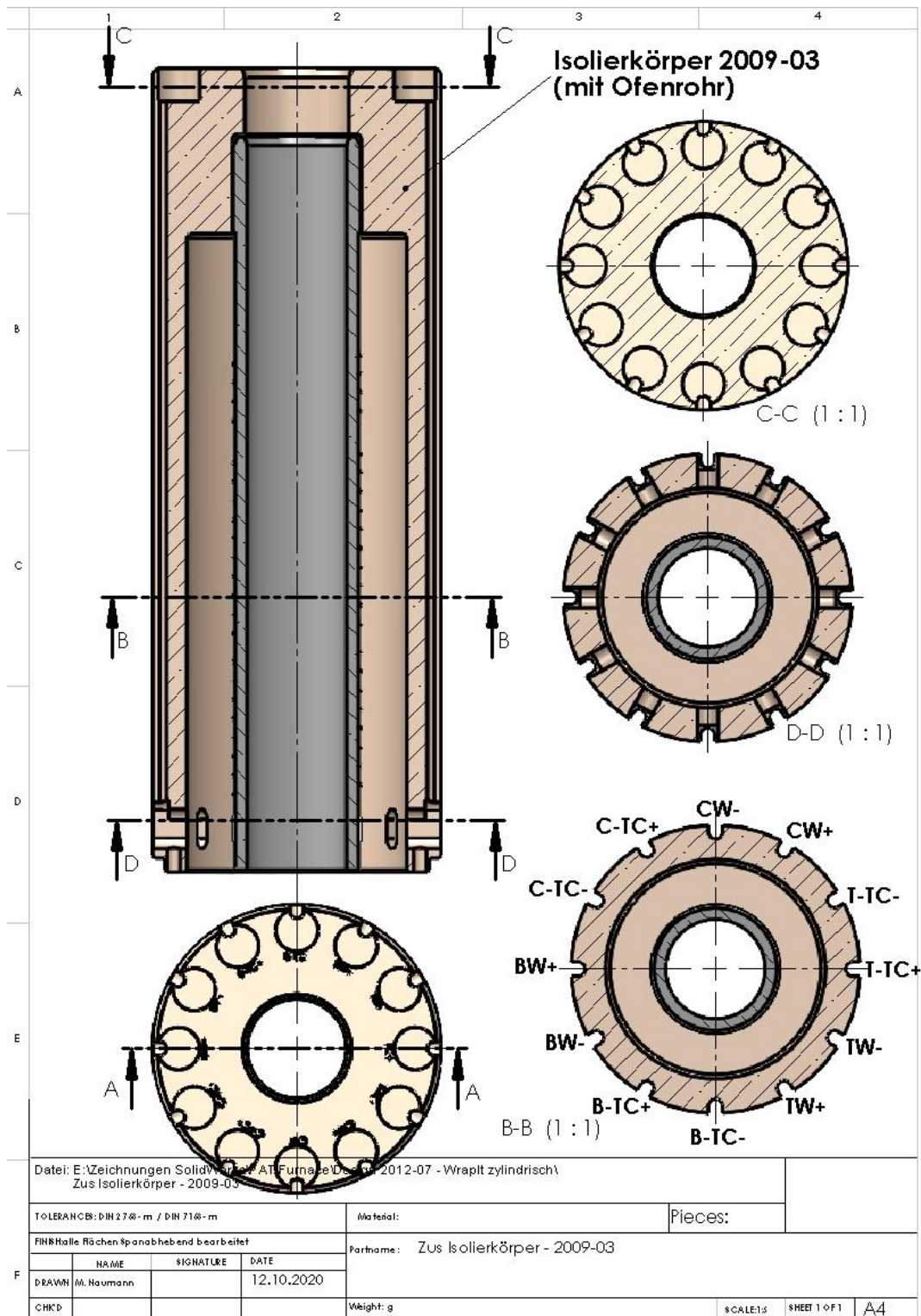

- Prepare and lengthen thin ceramic tubes of appropriate inner and outer diameter fitting into the grooves of the outer ceramic cylinder – 12x
- Insert leads of three twisted molybdenum wires into these ceramic tubes – 6x for the windings
- Insert copper wire or appropriate thermocouple compensation wire (+/-) into the thin ceramic tubes – 6x for the thermocouples

- Connect one end of the leads and the wires respectively to the connector sockets and tighten the screws
- Insert the socket with a copper (or compensation) wire into the bore at the top of the outer ceramic cylinder **counterclockwise of the mark of the reference bore** (top thermocouple positive - looking from top)
- Bend the wire appropriate and insert the ceramic tube into the groove of the outer ceramic cylinder
- Insert the other end of the wire into one of the bores of the bottom connection block and tighten the screw
- Bend the wire appropriate that the bottom connection block fits into the notch at the bottom end of the outer ceramic cylinder showing its second bore to the bottom end
- Continue inserting the ceramic tubes with leads and wires into all grooves of the outer ceramic cylinder, **take care of the sequence corresponding to the prepared marks and notes**
- Insert the prepared outer ceramic cylinder into the steel can from the top end and push it down as far as possible
- Insert the ceramic top ring (PSZ or Macor) into the steel can and onto the sockets **making sure that the reference bore is located in between the two wires of the top thermocouple (corresponding to the mark at the outer ceramic cylinder)**
- Insert the top steel ring
- Insert the screws into the three bores and tighten them

8.2.4.2. Assemble of the inner furnace part

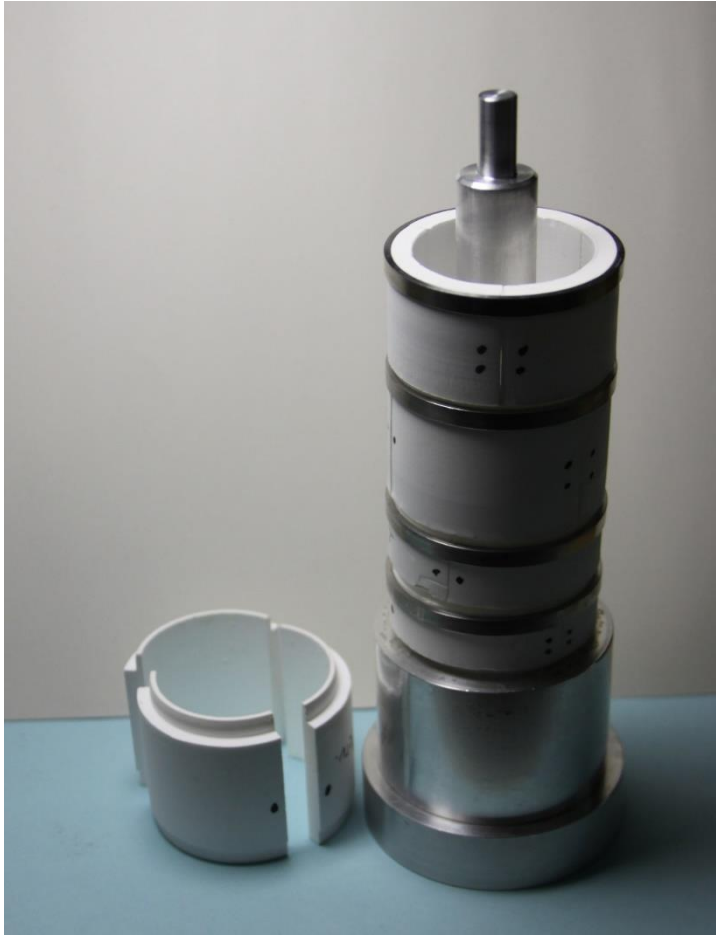

- Install thermocouples to the furnace tube at their appropriate position by gluing their tip and the wires to the ceramic at the tube and lead their wires to the bottom end of the furnace tube, **make sure there is no contact to the windings**
- Leave it several hours (i.e. overnight) in order to dry and harden the cement

- Install the furnace tube on the core of the cementing tool
- Install the first layer of Teflon segments (T)
- Insert fiber filled ceramic putty (WrapIt-372HT or other appropriate putty) uniformly distributed into the gap between the furnace tube and the Teflon segments in a gradual manner

- **Take care to fill sufficient ceramic putty underneath the leads of the windings, be carefully with these leads**
- Pack and constipate the ceramic putty in a gradual manner
- Continue inserting and constipating the ceramic putty with the following Teflon segments (CT/CB/B)

- Leave the cemented furnace tube inside the cementing tool one week in order to dry the ceramic putty

- Disassemble the Teflon segments layer by layer carefully

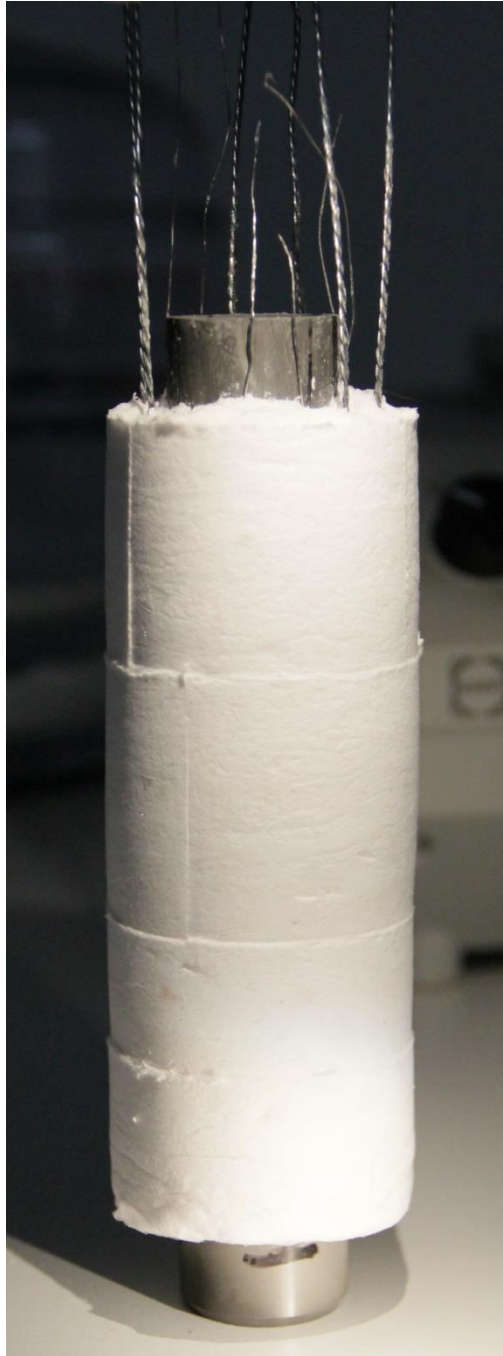

- Leave the cemented furnace tube again several days for further drying
- Bake the furnace tube in a furnace at approx. 1300 °C under argon atmosphere for about 48 hours at least, use slow heating and cooling ramps of about 1 K/min



- Smooth the surface of the ceramic putty carefully at a lathe or grinding machine to a diameter just one tenth of a millimeter smaller than the inner diameter of the outer ceramic cylinder, **take care not to damage the leads of the windings**
- Repair the surface of the ceramic putty with alumina oxide fibers (or ceramic putty) pushed into fissures

8.2.4.3. Completion of the whole furnace

- Insert the cemented furnace tube into the pre-assembled outer furnace part, push carefully, **take care of the orientation in angle in order to meet the correct leads and wires with its bottom connection blocks in the outer ceramic cylinder**

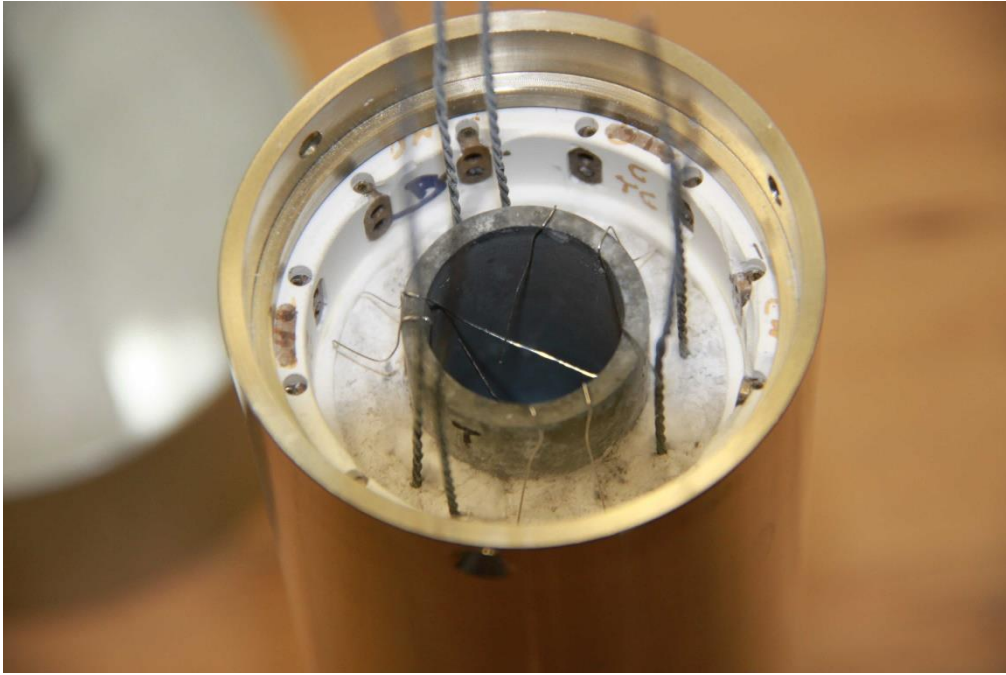

- Connect the leads and thermocouple wires to the correct bottom connection blocks and tighten these screws, **make sure not to touch the outer steel can with these leads and wires**



- Insert the bottom ceramic ring (NZP-ceramic or SALI) into the furnace
- Insert the bottom steel plate

- Insert the screws into the three bores and tighten them

9. Service and Maintenance

9.1. Change of O-Rings - Furnace-Feed-Throughs

9.1.1. Removal of the Furnace

- Vessel is open, no specimen inside
- Remove the bubbler hose from the vessel top nut
- Unscrew and remove the vessel top nut
- Disconnect the cables of all 6 electrical connections of the furnace
- Unscrew these radial connector-screws from the furnace top plug, pull them out some millimeters (they should not be visible in the borehole anymore)

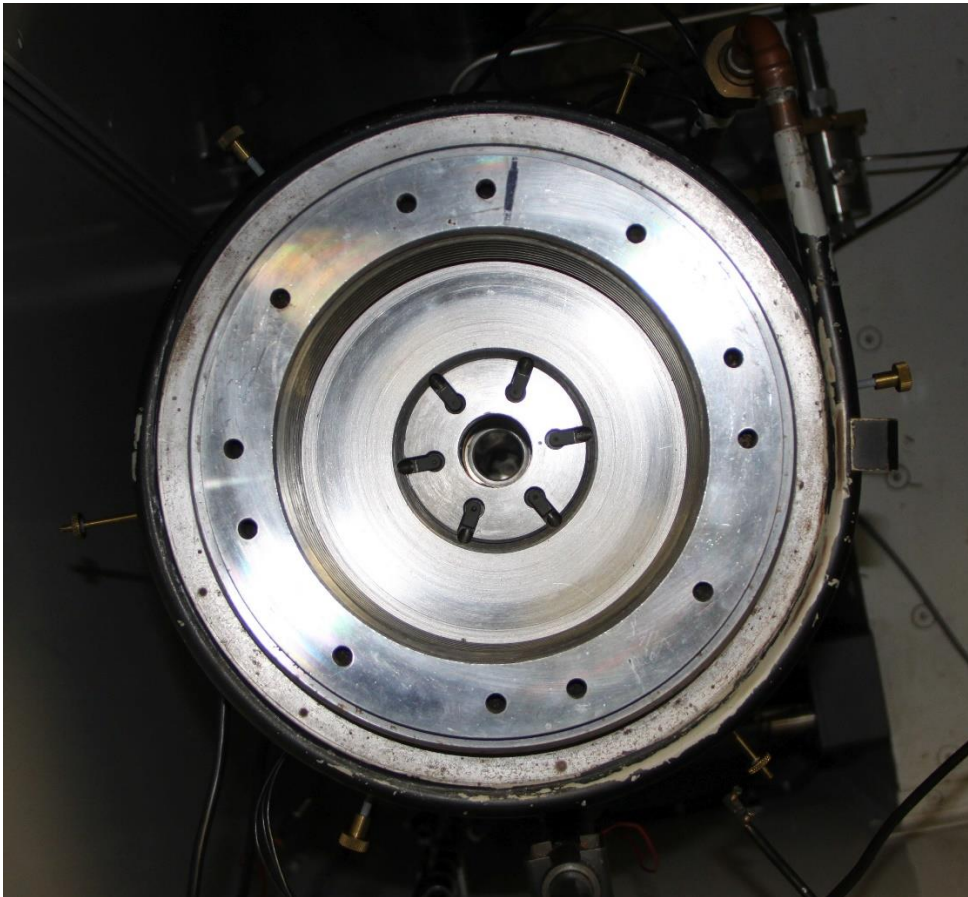

- Install the furnace pull-out-tool to the furnace top plug

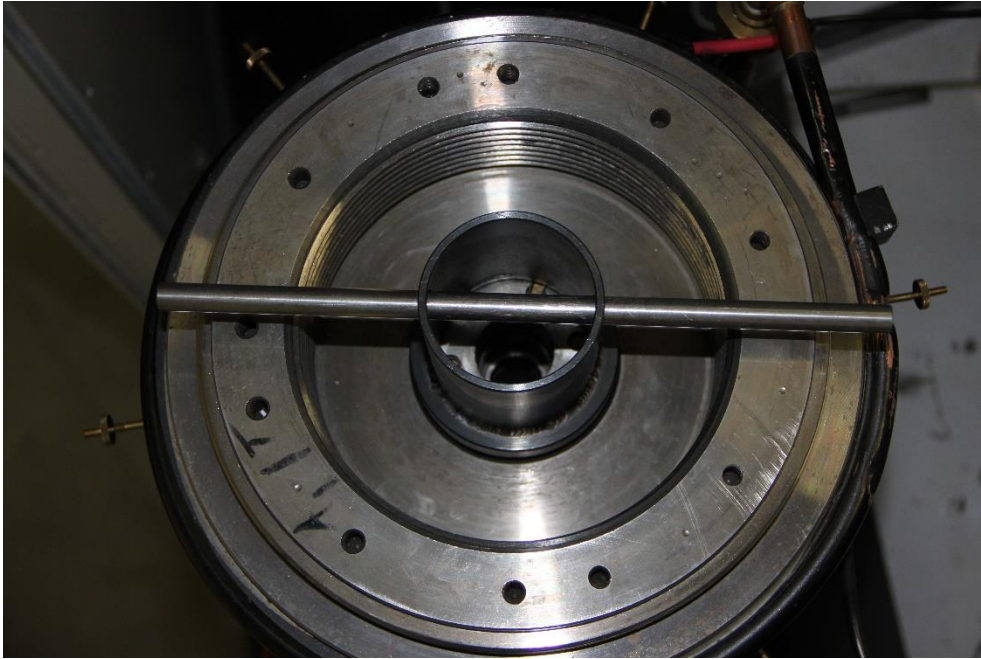

- Pull the furnace out of the vessel with an additional rod through the boreholes at the pull-out-tool (it may be quite hard due to a swollen O-ring)

9.1.2. Disassemble the Furnace

- Keep the furnace pull-out-tool at the furnace top plug
- Remove with a screw M2,5 the three small bolts out of the furnace top plug and can
- Pull the furnace out of its can



- Remove the furnace top plug from the furnace
- Store the furnace under dry conditions (i.e. in an oven at 120°C)

9.1.3. Change of O-Rings

- Remove the furnace pull-out-tool
- Unscrew and remove the six ground connectors with the special socket wrench (decreased diameter at the appropriate end)

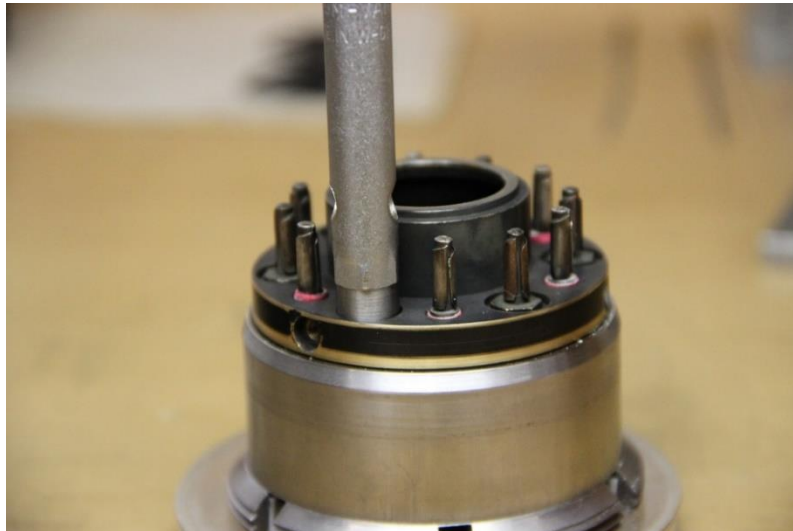

- Remove the plate from the main body of the furnace top plug
- Remove the specimen top plug sealing (O-ring and Mitre-ring) of the center borehole, **do not create scratches in the borehole**
- Pull out all six electrical feed-throughs (quite often the O-rings and washers remain inside the borehole as well as the heat-shrink in the smaller bore)



- Remove the O-rings and PSZ-washers of the boreholes carefully, **do not create scratches in the boreholes**
- Remove the heat-shrink of the small boreholes
- Clean the center borehole and all feed-through-boreholes with cotton wool and alcohol carefully
- Check the center borehole and all feed-through-boreholes for scratches or other damages
- Clean the sealing diameter of all feed-throughs with cotton wool and alcohol carefully
- Check the sealing diameter at all feed-throughs for scratches or other damages
- Check the heat-shrink (both, the one at the feed-through next to the plug and the small one of the thin pin) and replace those, if not intact
- Check the PSZ-washers and replace those, if necessary
- Install the PSZ-washer and the heat-shrink onto the small pin of each feed-trough
- Install two new O-rings 010 (NBR 70) at the sealing diameter of each feed-trough
- Install the Teflon cover on top of the O-rings



- Grease the O-rings 010 with Molykote M-55 slightly
- Push the assembled feed-through into the borehole with the help of the small plastic tool

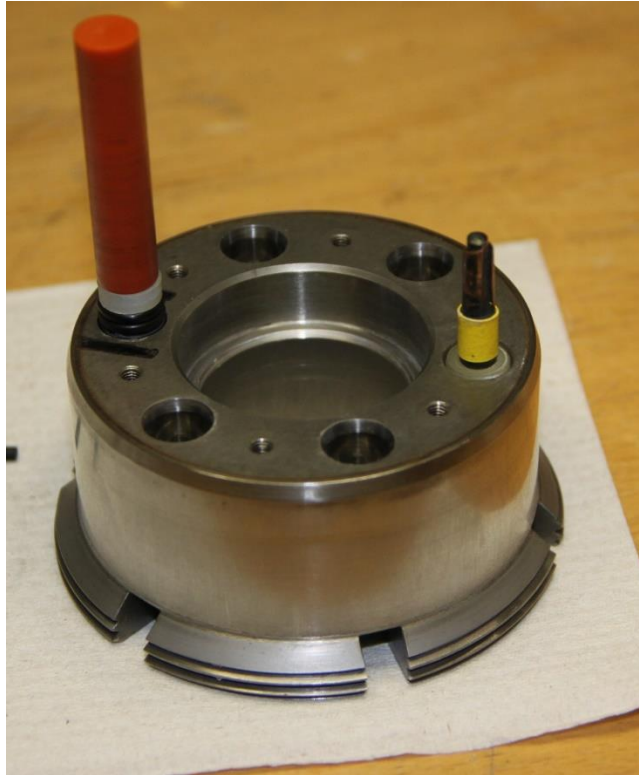

- Install a new O-ring 217 (NBR 70) and the checked Mitre-ring in the center borehole, use a bit of Molykote M-55 at the O-ring



- Install the plate to the main body

- Screw and tighten the six ground connectors with the special socket wrench

9.1.4. Reinstallation of the Furnace

- Check for scratches or damages at the sealing diameter of the furnace top plug (if there are some, try to polish those out with polish grease and/or very fine grinding paper carefully)
- Screw the furnace pull-out-tool to the furnace top plug
- Install the furnace top plug to the furnace
- Push the furnace into its can
- Insert the three small bolts into the boreholes of the can and the furnace top plug
- Grease the taper for the sealing at the furnace top plug with Molykote M-55 slightly

- Push the furnace into the vessel
- **Make sure, that the mark at the furnace top plug shows to the front of the machine, this mark corresponds with the connector of the top thermocouple**
- Remove the furnace pull-out-tool
- Screw the radial connector-screws into the brass-connectors at the furnace top plug
- Connect the **correct** cables of all 6 electrical connections to the furnace
- Install and screw the vessel top nut down to the end of the thread, **do not tighten this nut**

9.2. Change of O-Rings – Bottom Plug and ILC

9.2.1. Removal of the Bottom Plug

- Vessel is open, no specimen inside
- Remove the furnace (described in section 9.1.1.)

- Install the long support bar by screwing it into the top cap of the bottom plug
- Retain this support bar with a thin cross-rod through one of its boreholes

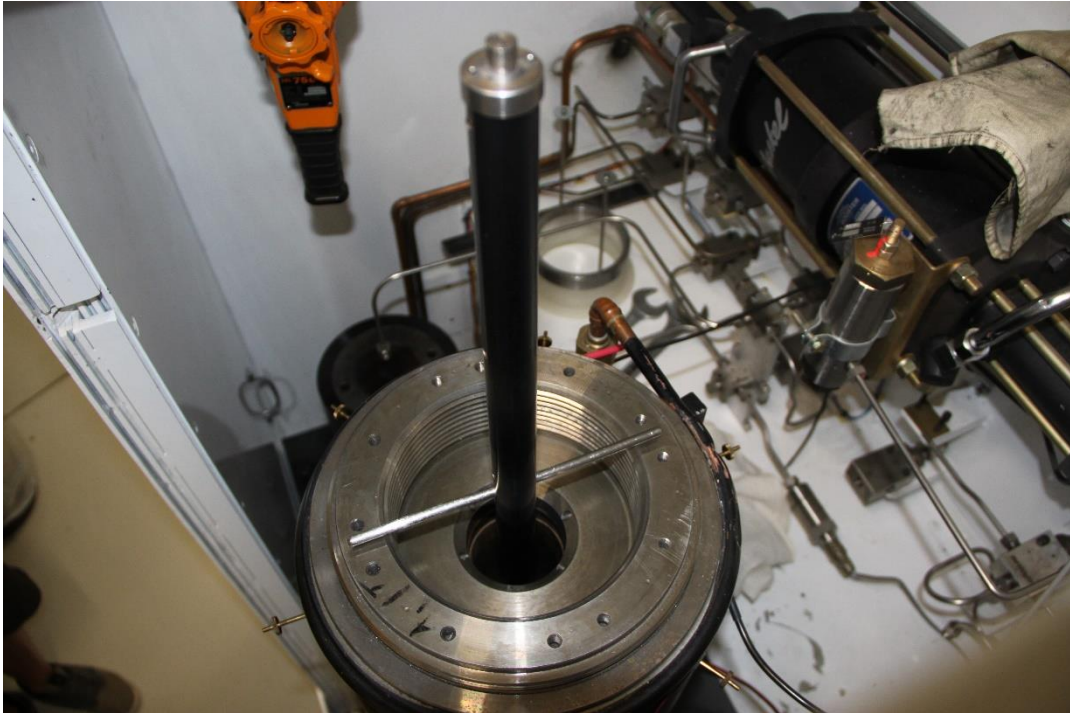

- Enable manual movement of the axial actuator (this is different for the two machines, refer to the Manual)
- → No.4 : Use the key at the key-switch at the back of the machine underneath the stairs, the actuator moves as long as the key-switch is twisted (check for the Up- and Down-direction !), the actuator stops by releasing the key-switch
- → No.7 : Set the limit override-switch at the top of the motor amplifier to ON, switch the speed control to DOWN and set an suitable speed with the speed control demand, use the green button next to the rear door, the actuator moves as long as the button is pushed, the actuator stops by releasing the button

- → Be very careful when moving the axial actuator, if you go too far down, you may rupture the cable-stem of the internal load cell
- Unscrew the support of the external DCDT at the stirrup





- Disconnect all cables at the bottom of the vessel and disconnect the hose of the bubbler



- Move the axial actuator down until the open-end wrench (27) fits into the gap between the bottom of the vessel and the top of the stirrup, **do not go further down at this step**

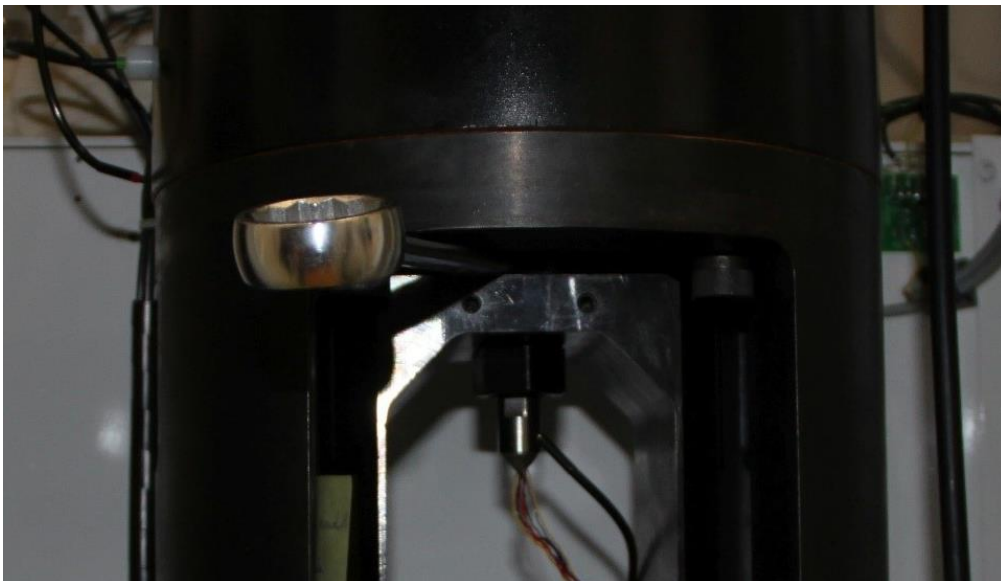



- Use this open-end wrench (27) to fix/hold the piston and use another open-end wrench (32) to untighten the piston nut at the stirrup, keep the nut loose nearby the stirrup
- Unscrew and remove all 8 screws at the bottom of the spacer of the external load cell
- Unscrew and remove all 12 screws at the external load cell (ELC)
- Move the axial actuator down until it is possible to take out the ELC and its spacer



- Unscrew the piston nut meanwhile supporting the stirrup manually at its position
- Move stirrup down and remove it out of the vessel support frame
- Unscrew the bottom nut of the vessel with its tool and remove it



- Support the bottom plug at its bottom meanwhile another person at the top of the vessel takes the thin cross-rod out of the borehole at the support bar and lowers/pushes down the bottom plug
- Continue supporting the bottom plug meanwhile the second person unscrews the support bar
- Take the bottom plug out of the vessel support frame carefully, **take care of the cable-stem with the cables**

9.2.2. Change of O-Rings in the Bottom Plug

- Place the bottom plug nearly horizontal at the bottom plug support cylinder

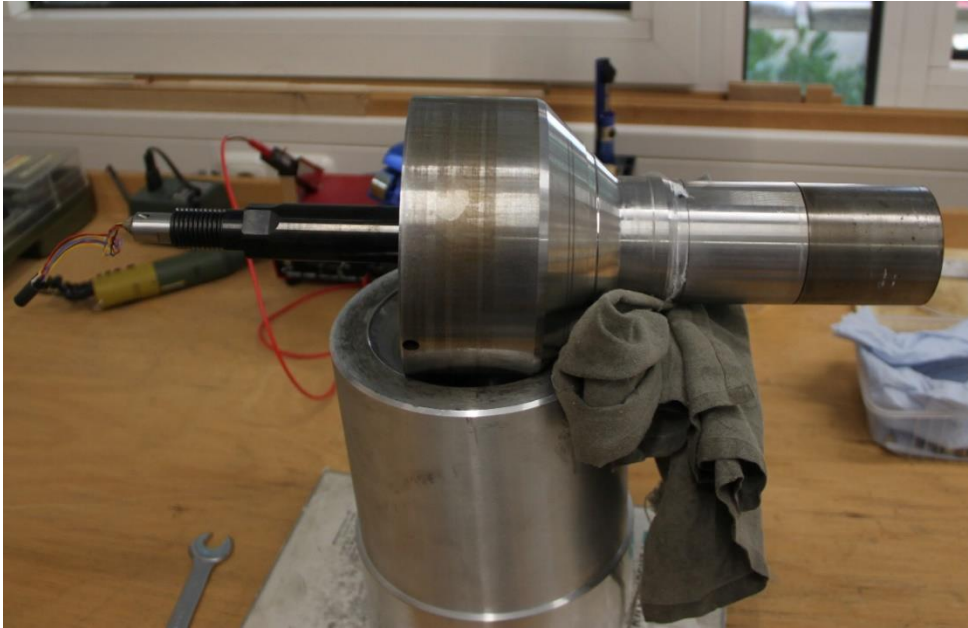

- Unscrew the nut at the cable-stem and the bottom end of the piston and remove it

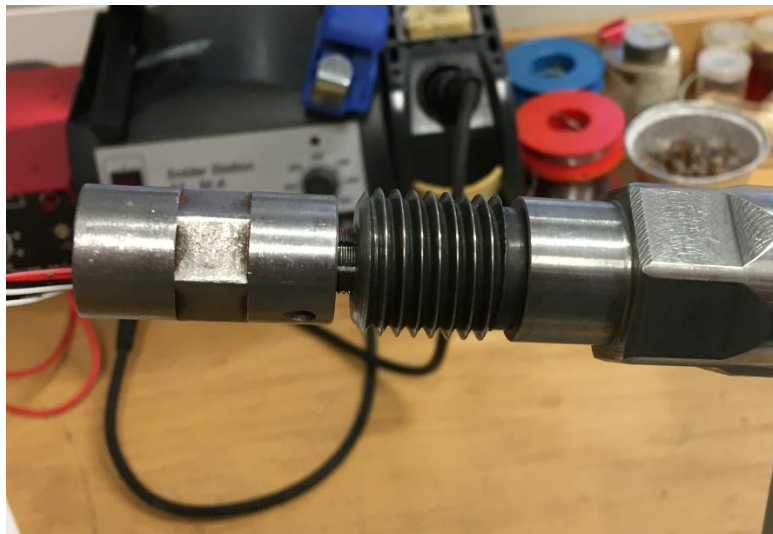

- Place the bottom plug vertical with its bottom at the bottom plug support cylinder
- Unscrew the top cap of the bottom plug



- Pull out the Internal load cell piston carefully (it may be quite hard due to a swollen O-ring), **take care of the cable-stem**



- Push out the lower compensation piston with a convenient tool (it is quite hard due to swollen O-rings)



- Remove the seal ring from the compensation piston (it may be quite hard due to a swollen O-ring)
- Remove all O-rings and Mitre-rings in the bottom plug and the seal ring
- Clean all sealing grooves and surfaces in the bottom plug and the seal ring with cotton wool and alcohol carefully, **do not create scratches in the grooves**
- Clean both pistons with alcohol carefully, **do not create scratches**
- Check for scratches or damages at the pistons (if there are some, try to polish with tangential moves with polish grease and/or very fine grinding paper carefully)
- Check the Mitre-rings for any damage
- Change the O-rings inside the ILC, if necessary (described in section 9.2.3.)
- Turn the bottom plug upside down at the bottom plug support cylinder

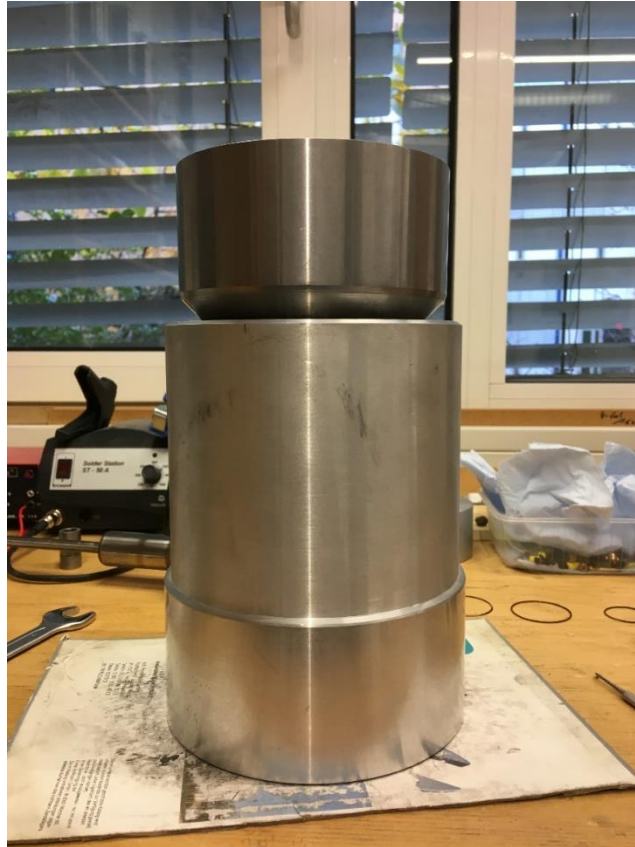

- Insert the first Mitre-ring into the deeper sealing groove followed by the O-ring 223 (NBR 70), use a bit of Molykote M-55 at the O-ring, **this O-ring sits on top of the Mitre-ring**
- Insert the second Mitre-ring into the upper sealing groove followed by the O-ring 223 (NBR 70), use a bit of Molykote M-55 at the O-ring, **this O-ring sits underneath the Mitre-ring**



- Place the bottom plug again with its bottom at the bottom plug support cylinder
- Insert the Mitre-ring into the sealing groove followed by the O-ring 217 (NBR 70), use a bit of Molykote M-55 at the O-ring, **this O-ring sits on top of the Mitre-ring**
- Grease the taper for the sealing at the internal load cell piston with Molykote M-55 slightly
- Insert the internal load cell piston into the bottom plug and push it through the O-ring carefully, **take care of the cable-stem**
- Screw the top cap onto the bottom plug and tighten it
- Turn the bottom plug upside down at the bottom plug support cylinder, **take care of the cable-stem**
- Push the compensation piston over the long stem with the cables, **take care of the cable-stem**



- Insert the compensation piston into the bottom plug and push it through the O-rings carefully

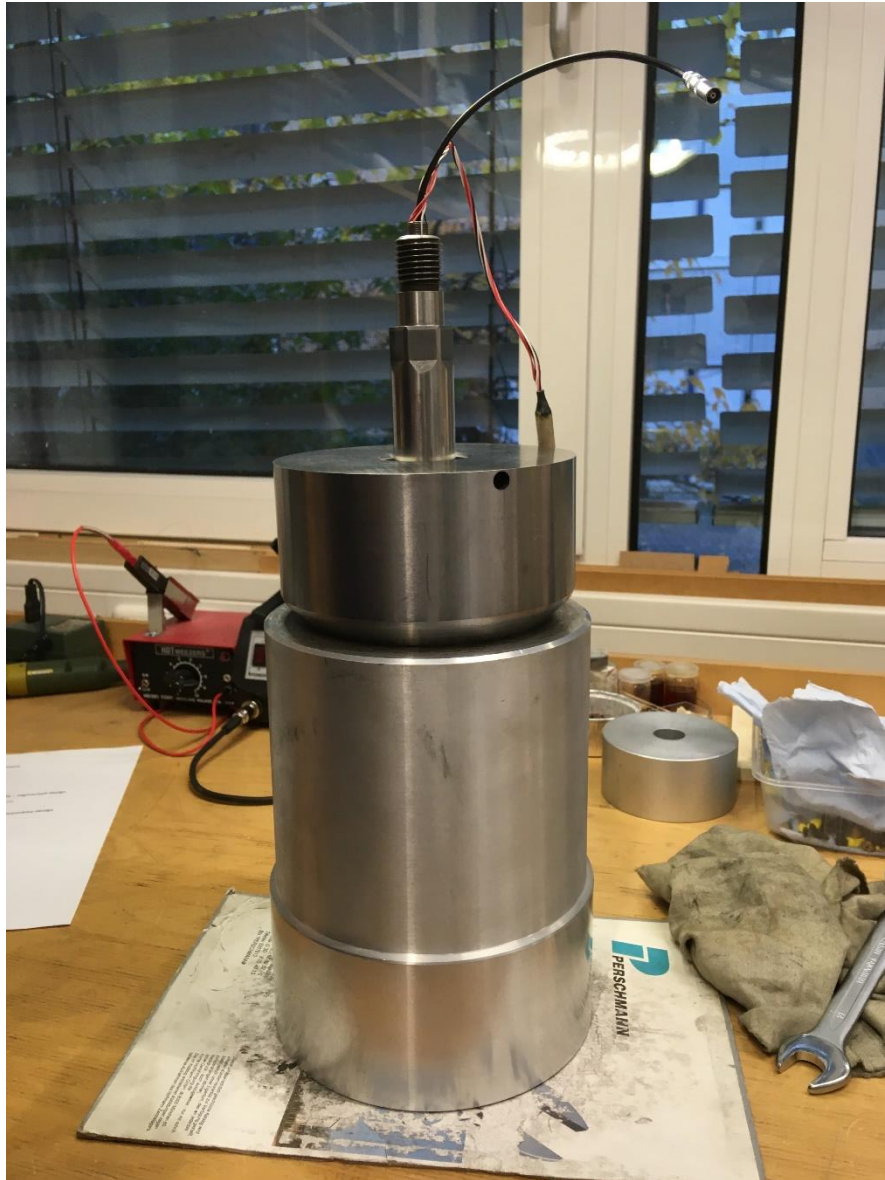

- Screw the nut onto the cable-stem and tighten it slightly at the bottom end of the piston
- Insert the Mitre-ring into the sealing groove of the seal ring followed by the O-ring 217 (NBR 70), use a bit of Molykote M-55 at the O-ring, **this O-ring sits on top of the Mitre-ring**
- Push the seal ring onto the compensation piston and push it through the O-ring carefully



- Close the bore of the nut of the stem with elastic putty around the cables
- Place the bottom plug nearly horizontal at the bottom plug support cylinder
- Continue with the reinstallation of the bottom plug (described in section 9.2.5.)

9.2.3. Change of O-Rings inside ILC (normally not necessary)

- There is an O-ring installed in between the top of the two hollow cylinders of the internal load cell
- To replace this O-ring it is necessary to take out the internal LVDT- or US-block respectively

9.2.3.1. Open top of the ILC

- Unscrew the top cap of the internal load cell piston and remove it



- Remove the two half rings, which were covered by the top cap



- Unscrew the inner anvil part (internal bayonet) and remove it

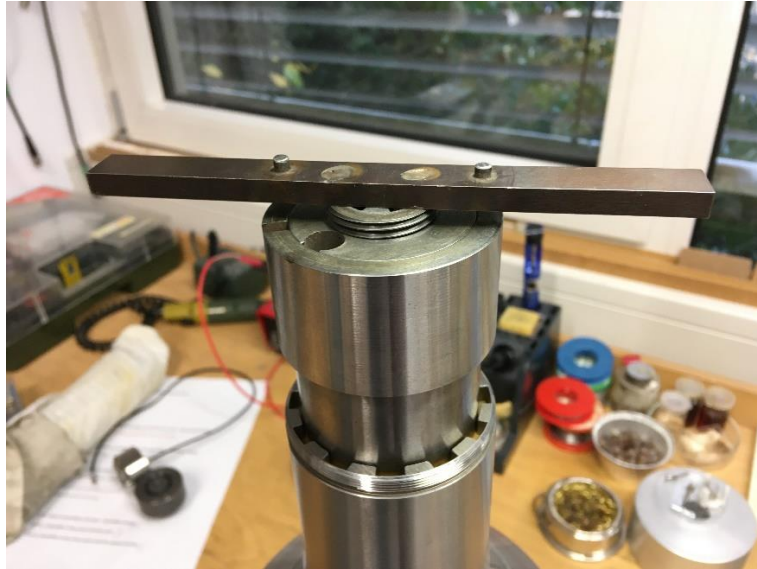

- Pull out the outer anvil part, use the top specimen piston (old design with a sealing-thread and nut, which fits into outer anvil part)





9.2.3.2. Removal of the internal blank block

- Unscrew and remove the two screws at the blank block (sometimes these screws may not be installed)



- Pull out the LVDT-block, **take care of the cable-stem**

9.2.3.3. Removal of the internal LVDT-Block (LVDT & feed-throughs)

- Unscrew and remove the two screws at the LVDT-block (sometimes these screws may not be installed)
- Pull out the LVDT-block, **take care of the cable-stem**
- Pull out the closure plug at the top of the LVDT-block
- Remove the O-rings at the closure plug and the bottom of the LVDT-block
- Clean all sealing grooves and surfaces with cotton wool and alcohol carefully, **do not create scratches in the grooves**
- Insert the LVDT-block into the internal load cell cylinder with an O-ring 116 (NBR 70) in its groove at the bottom, grease the O-ring with Molykote M-55 slightly, **take care of the cable-stem**
- Insert the two screws and tighten them (if they were installed)
- Insert the closure plug with an O-ring 012 (NBR 70) into the borehole at the LVDT-block, grease the O-ring with Molykote M-55 slightly
- Close the top of the ILC

9.2.3.4. Removal of the internal US-Block (sensor & feed-through)

- Disassemble the coaxial Lemo-socket at the end of the coax-cable coming out of the lower end of the cable stem



- Unscrew and remove the two screws at the US-block, **take care of the US-sensor and its Teflon cage** (sometimes these screws may not be installed)

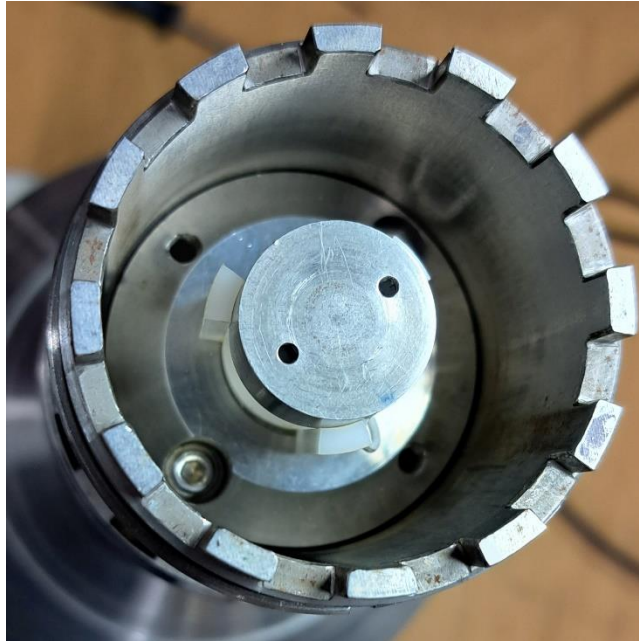

- Pull out the US-block, **take care of the coax-cable and the US-sensor with its Teflon cage** (some additional screws may be helpful)



- Remove the O-ring at the bottom of the US-block
- Clean all sealing groove and surface with cotton wool and alcohol carefully, **do not create scratches in the groove**
- Insert the US-block into the internal load cell cylinder with an O-ring 116 (NBR 70) in its groove, grease the O-ring with Molykote M-55 slightly, **take care of the cable and the US-sensor with its Teflon cage**

- Re-assemble the coaxial Lemo-socket
- Insert the two screws and tighten them (if they were installed)
- Close the top of the ILC

9.2.3.5. Disassemble and reassemble ILC

- Normally it is not necessary to replace the O-ring 033 in between the two hollow cylinders of the internal load cell

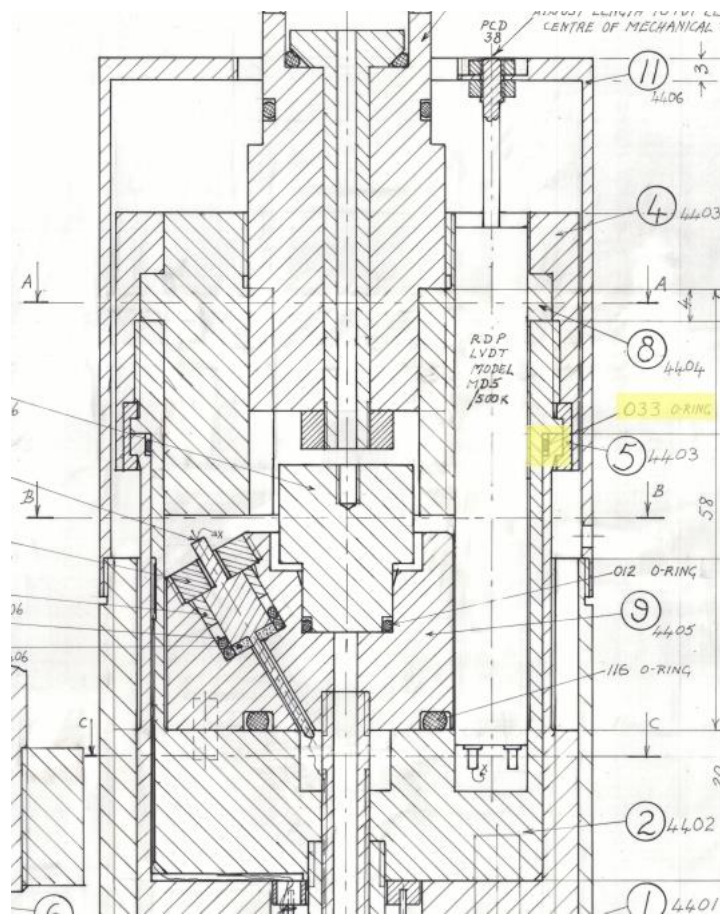

- Hold the internal load cell piston and pull at the inner load cell cylinder (it may be quite hard due to a swollen O-ring) until there is access to the O-ring, **take care of the cable-stem**
- Remove the O-ring carefully, **take care of the strain gauges and wires**
- Clean all parts carefully
- Push the inner load cell cylinder into the internal load cell piston closely, leave a small gap
- Insert a new O-ring 033 (NBR 70) into this gap, do not use any grease
- Squeeze the O-ring into the slit at the load cell piston with an appropriate tool carefully, **do not cut or damage the O-ring**

- Push the two parts tight together
- Insert the LVDT-block or the US-block into the internal load cell cylinder (refer to 9.2.3.2. & 9.2.3.3.)
- Insert the outer anvil part
- Attach the two half rings to the internal load cell piston
- Screw the top cap onto the internal load cell piston
- Screw the inner anvil part into the outer anvil part

9.2.4. Change of O-Rings of the Feed-Throughs (normally not necessary)

9.2.4.1. Internal LVDT-Block

- There are electrical feed-throughs in the LVDT-block (those are used for the electrical connections of the internal LVDT, if installed)
- Unsolder all 4 cables from the feed-throughs at the top and the bottom (stem)
- Unscrew the 4 Teflon nuts with an appropriate tool
- Pull out the electrical feed-throughs (quite often the O-rings and washers remain inside the borehole as well as the heat-shrink in the smaller bore)
- Remove the O-rings and PSZ-washers of the boreholes carefully, **do not create scratches in the boreholes** (if those remain inside)
- Remove the heat-shrink of the small boreholes (if it remains inside)
- Clean all feed-through-boreholes with cotton wool and alcohol carefully
- Check all feed-through-boreholes for scratches or other damages
- Clean the sealing diameter of all feed-throughs with cotton wool and alcohol carefully
- Check the sealing diameter at all feed-throughs for scratches or other damages
- Check the heat-shrink and replace those (if not intact)
- Check the PSZ-washers and replace those (if necessary)
- Install the PSZ-washer and the heat-shrink onto the small pin of each feed-trough
- Install two new O-rings 010 (NBR 70) at the sealing diameter of each feed-trough
- Install the Teflon cover on top of the O-rings
- Grease the O-rings 010 with Molykote M-55 slightly
- Push the assembled feed-through into the borehole with the help of the small plastic tool
- Insert the Teflon screw and tighten it slightly
- Solder all cables to the feed-throughs at the top and the bottom (stem)

9.2.4.2. Internal US-Block

- There is a coaxial electrical feed-through in the US-block underneath the Teflon cage of the US-sensor

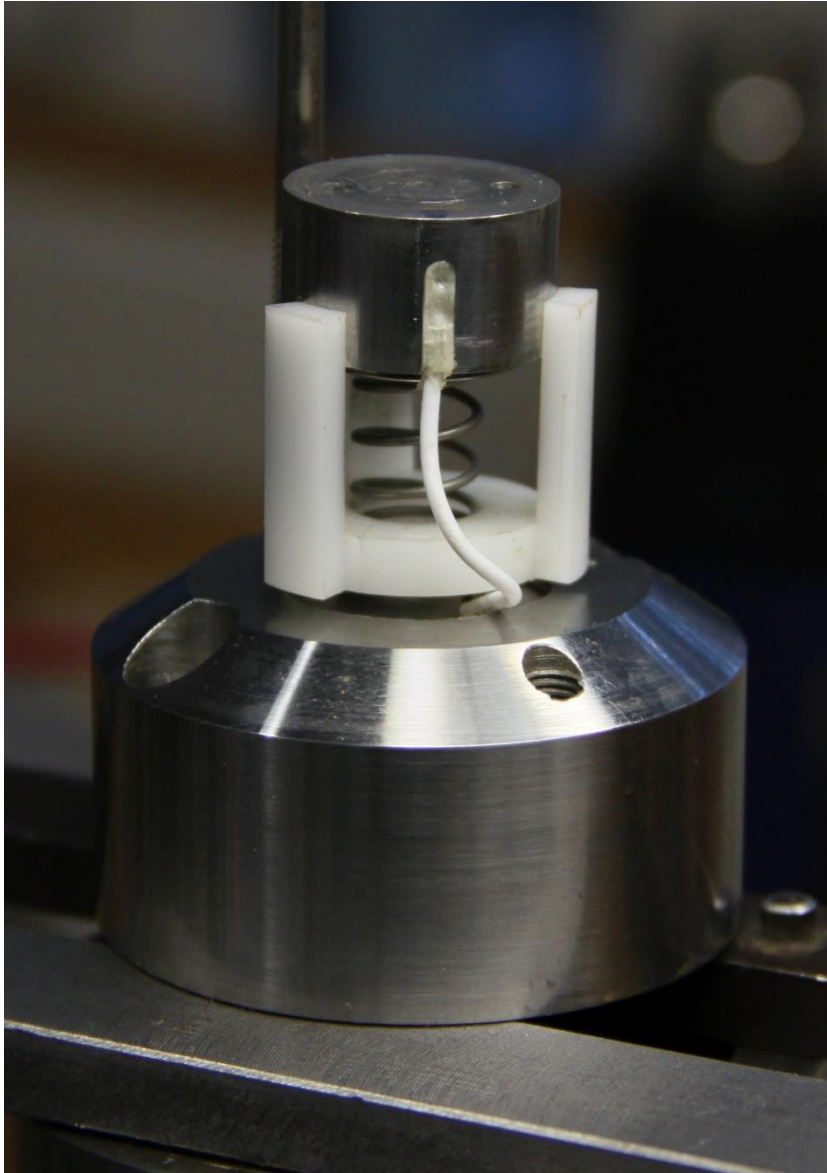



- Remove the Teflon cage
 - Unsolder the cable (live and shield) from the feed-through at the top and remove the US-sensor
 - Unscrew the big Teflon nut with an appropriate tool
 - Pull out the complete coaxial electrical feed-through (quite often the O-rings and the washer remain inside the borehole as well as the heat-shrink in the smaller bore), **take care of the cable and the Lemo-socket**
 - Remove the O-rings and the PSZ-washer of the borehole of the US-block carefully, **do not create scratches in the borehole** (if those remain inside)
 - Remove the heat-shrink of the small borehole (if it remains inside)
 - Clean all feed-through-borehole of the US-block with cotton wool and alcohol
 - Check the feed-through-borehole for scratches or other damages
-
- Unsolder the cable (live and shield) from the still assembled coaxial feed-through at the bottom
 - Unscrew the small Teflon nut with an appropriate tool
 - Pull out the inner part of the coaxial electrical feed-through (quite often the O-rings and the washer remain inside the borehole as well as the heat-shrink in the smaller bore)

- Remove the O-rings and PSZ-washer of the borehole of the outer part of the feed-through carefully, **do not create scratches in the boreholes** (if those remain inside)
- Remove the heat-shrink of the small borehole (if it remains inside)
- Clean the feed-through-borehole with cotton wool and alcohol carefully
- Check the feed-through-borehole for scratches or other damages
- Clean the sealing diameter of the inner and outer part of the feed-through with cotton wool and alcohol carefully
- Check the sealing diameter at both parts for scratches or other damages
- Check the heat-shrink and replace those (if not intact)
- Check the PSZ-washers and replace those (if necessary)

- Install the PSZ-washer and the heat-shrink onto the small pin of the inner part of the feed-trough
- Install two new O-rings 008 (NBR 70) at the sealing diameter of the inner part of the feed-trough
- Install the Teflon cover on top of the O-rings

- Grease the O-rings 008 with Molykote M-55 slightly
- Push the assembled inner part of the feed-through into its outer part
- Insert the Teflon screw and tighten it slightly

- Install the PSZ-washer and the heat-shrink onto the small pin of the outer part of the feed-trough
- Solder the cable (live and shield) to the feed-through at the bottom
- Install two new O-rings 014 (NBR 70) at the sealing diameter of the outer part of the feed-trough
- Install the Teflon cover on top of the O-rings

- Grease the O-rings 014 with Molykote M-55 slightly
- Push the assembled coaxial the feed-through into the borehole of the US-block, **take care of the cable and the Lemo-socket**
- Insert the Teflon screw and tighten it slightly

- Solder the cable (live and shield) of the US-sensor to the feed-through at the top
- Insert the Teflon cage into the bore on top of the coaxial feed-through
- Insert the US-sensor into its cage

9.2.5. Reinstallation of the Bottom Plug

- Check for scratches or damages at the sealing diameter of the bottom plug (if there are some, try to polish those out with polish grease and/or very fine grinding paper carefully)
- Grease the taper for the sealing at the bottom plug with Molykote M-55 slightly
- Insert the bottom plug carefully into the vessel support frame and hold it vertical, **take care of the cable-stem**
- Raise the bottom plug into the bottom of the vessel

- A second person at the top of the vessel screws the support bar into the top cap of the bottom plug, pulls it carefully into the vessel completely and retains the support bar with a thin cross-rod through one of its boreholes
- Screw the bottom nut into the vessel (easier with its tool) until the end of the thread, **do not tighten this nut**
- Insert the stirrup into the vessel support frame and raise it onto the end thread of the piston
- Screw the piston nut onto the piston meanwhile supporting the stirrup manually at its position, **do not tighten it yet**
- Continue supporting the stirrup manually at its position and insert the ELC and its spacer
- Release the stirrup, it moves down due to its own weight
- Move the axial actuator up until the ELC touches the stirrup and starts to move it up, **make sure, the ELC sits perfect inside the bottom of the stirrup**
- Move the axial actuator further up until the open-end wrench (27) between the bottom of the vessel and the top of the stirrup is almost trapped
- Screw all 12 screws at the ELC and tighten them
- Screw all 8 screws at the bottom of the ELC spacer and tighten them
- Tighten the piston nut with the open-end wrench (32) meanwhile fixing/holding the Piston with the open-end wrench (27)
- Connect the cables (ILC, int. LVDT or ext. DCDT, ELC,...) at the bottom of the vessel and connect the hose of the bubbler
- Move the axial actuator further up to its usual position
- Disable manual movement of the axial actuator (in reversed order corresponding to the description given in section 9.2.1.)
- Take the thin rod out of the borehole at the support bar and unscrew it from the top of the bottom plug
- Insert the furnace (described in section 9.1.4.)

9.3. Change of O-Rings – Pressure Vessel

- If necessary, the change of the O-rings of the vessel usually is done together with the change of the O-rings of the furnace feed-throughs and the O-rings of the bottom plug, respectively
- For both – the O-ring at the top and the bottom – the procedure is similar
- Vessel is open, no specimen inside
- Remove the furnace (described in section 9.1.1.)
- Remove the Bottom Plug (described in section 9.2.1.)
- Extract the O-ring and the Mitre-ring with an appropriate tool
- Check the Mitre-ring, if it may be used again
- Clean the groove of the sealing with cotton wool and alcohol carefully

- Insert the Mitre-ring into the sealing groove followed by a new O-ring ____ (NBR, 70shore), grease the O-ring with Molykote M-55 slightly, **looking into the borehole this O-ring sits behind the Mitre-ring**
- Reinstall the bottom plug (described in section 9.2.5.)
- Reinstall the furnace (described in section 9.1.4.)

9.4. Change of O-Rings - Intensifier

9.4.1. Change of the Gas O-Ring

- Release all gas pressure out of the system
- Move the pistons of the intensifier to about half-way of its stroke by pumping
- Loose the gland nut at the tee of the intensifier gas line at the front wall of the machine
- Unscrew the gland nut at the top of the intensifier
- Move the tube away
- Check, if the gas cylinder moves freely in the thread of the oil cylinder
- Screw the coupling of the hoist completely into the gas line connector at the intensifier



- Operate the hoist for taking the weight of the cylinder meanwhile unscrewing the Gas cylinder

- Raise the cylinder carefully to the upper most position of the hoist
- Cover the oil cylinder to prevent dirt inside



- Attach the split clamp to the gas piston firmly, **do not create scratches**

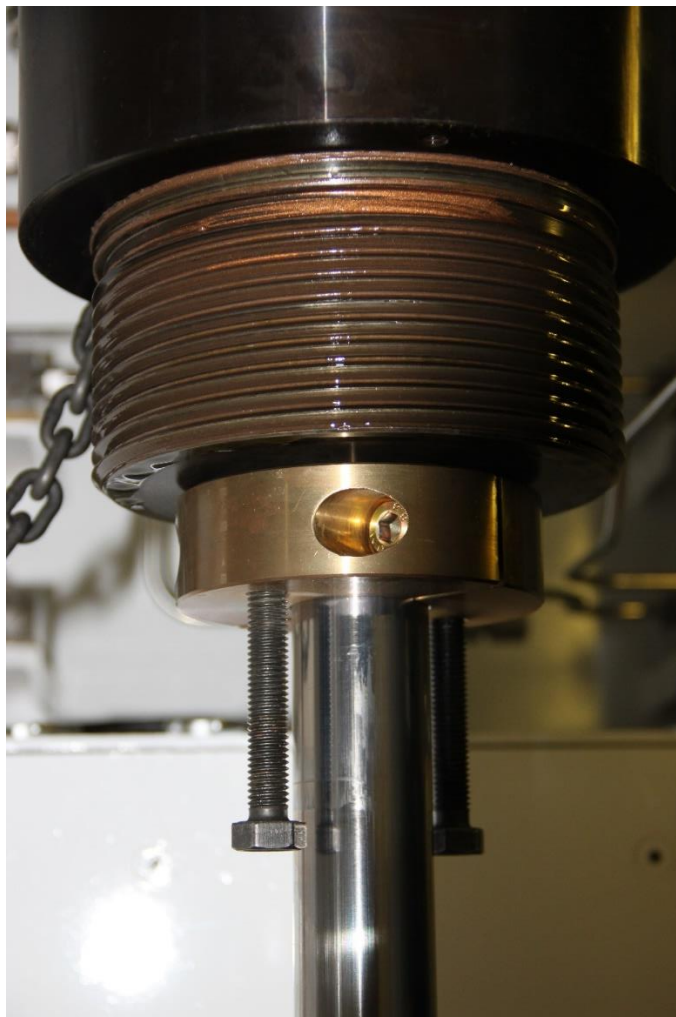

- Remove the gas piston with the help of the split clamp, **do not create scratches**
- Extract the O-ring and the Mitre-ring
- Check the Mitre-ring, if it may be used again
- Clean the groove of the sealing with cotton wool and alcohol carefully
- Clean the gas piston
- Check for scratches or damages at the gas piston (if there are some, try to polish those out with polish grease and/or very fine grinding paper carefully)

- Insert the Mitre-ring into the sealing groove followed by a new O-ring 223 (Polyurethan, 90shore), grease the O-ring with Molykote M-55 slightly, **look into the borehole that the O-ring sits behind the Mitre-ring**
- Grease the taper for the sealing at the end of the gas piston with Molykote M-55 slightly
- Remove the cover of the oil cylinder
- Insert the gas piston into the gas cylinder, **make sure it does not fall down through its own weight**
- Cover the oil cylinder again and let the gas cylinder sit at this cover
- Push the gas piston through the O-ring with the weight of the gas cylinder by lowering the gas cylinder with the hoist carefully
- Remove the cover of the oil cylinder



- Continue lowering the gas cylinder carefully until the gas piston touches the oil piston, **make sure it fits perfect into its seat**

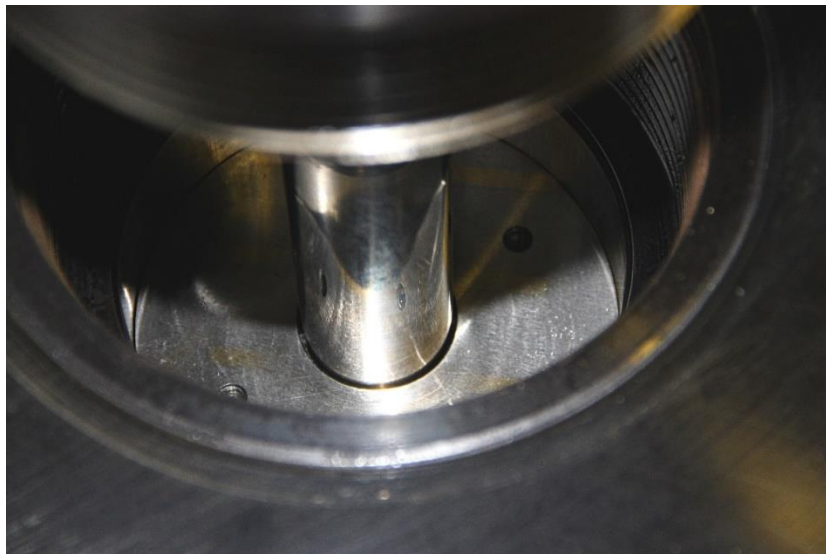
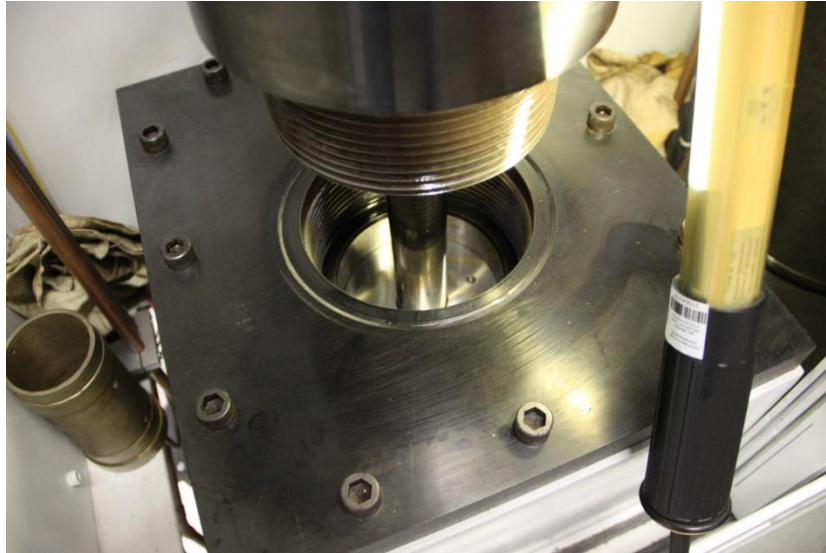

- Continue lowering the gas cylinder with the hoist until the threads start to mesh
- Screw the gas cylinder into the thread of the oil cylinder meanwhile continuously lowering the gas cylinder with the hoist
- Near full engagement continue slowly, **be careful not to tighten the thread, keep it slightly loose**
- Remove the coupling of the hoist
- Connect the gland nut to the top of the intensifier and tighten it
- Tighten the loose gland nut at the tee
- Open the valves of the gas supply gently to push the pistons down to the bottom of the oil cylinder

9.4.2. Change of the Oil O-Ring

- A change of this O-ring is necessary only, if there is oil on top of the oil piston (usually combined with a loss of oil in the oil level indicator)
- Open the intensifier, lift up the gas cylinder and remove the gas piston (described in section 9.4.1.)
- Move the oil piston up due to pumping until the lower end of the oil level indicator
- Remove the oil on top of the oil piston with a syringe (i.e.)



- Open the oil reservoir and add 1,5 liters of oil (two blue bottles) into this reservoir
- Move the oil piston further up due to pumping until the top end of the oil cylinder bore
- Screw two screws (necessary for removing) into the oil piston



- Move the oil piston further up due to pumping until it is completely outside the oil cylinder

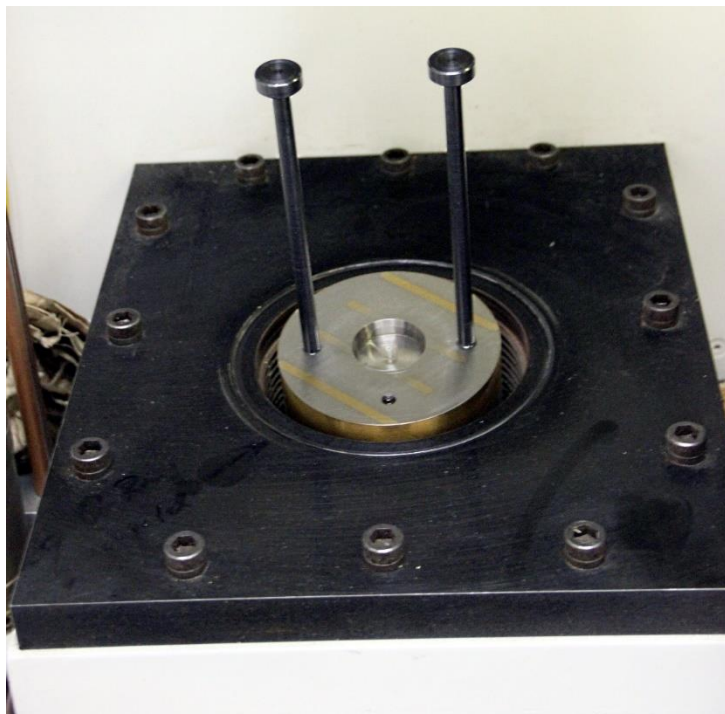

- Remove the oil piston
- Cover the oil cylinder to prevent dirt inside
- Position a container of sufficient volume (2 liters) underneath the oil cylinder

- Unscrew the gland nut at the lower end of the intensifier and release 2 liters of oil

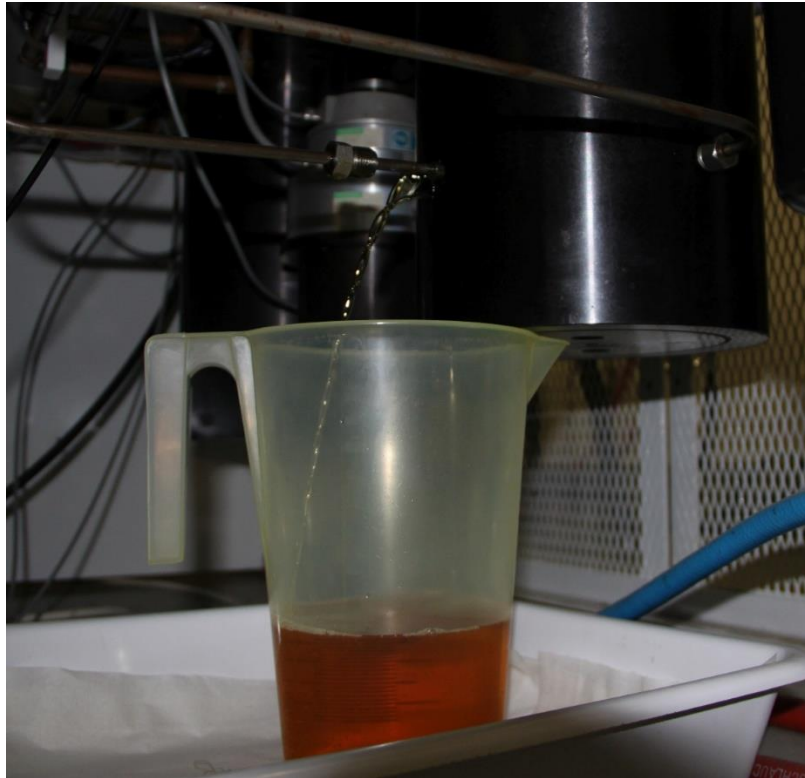

- Tighten the gland nut again
- Remove the O-ring and the Mitre-ring of the oil piston
- Remove the back-up-ring (if installed)
- Unscrew the vent screw and remove it
- Remove the valve ball out of the vent bore with a magnet of appropriate size

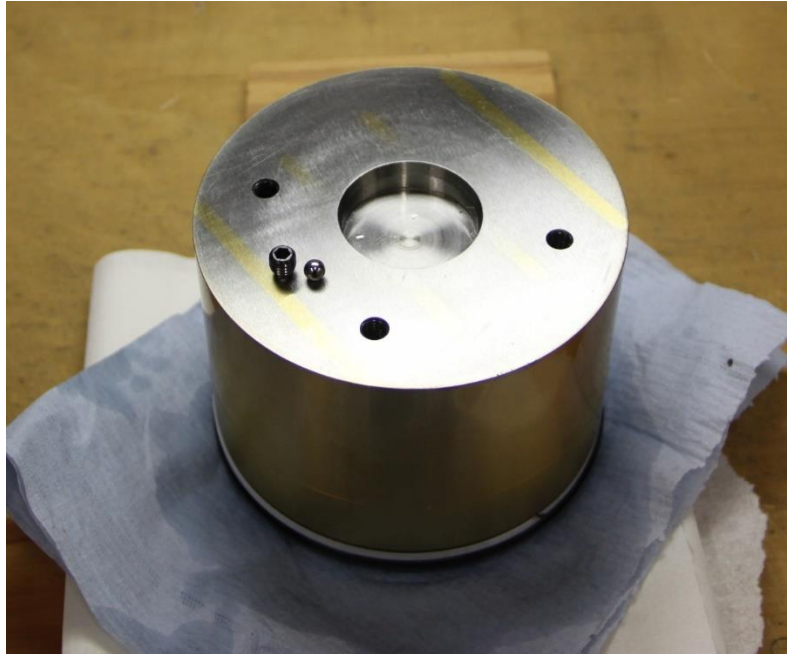

- Clean the oil piston
- Clean and check the Mitre-ring
- Clean and check the back-up-ring (if installed)
- Insert the Mitre-ring into the sealing groove followed by the back-up-ring (if installed) and a new O-ring 426 (NBR 90), grease the O-ring with Molykote M-55 sufficient
- **Use the two sleeves for inserting and guiding the piston if the taper at the top of the oil cylinder is less than 10mm long (as shown in the drawing)**

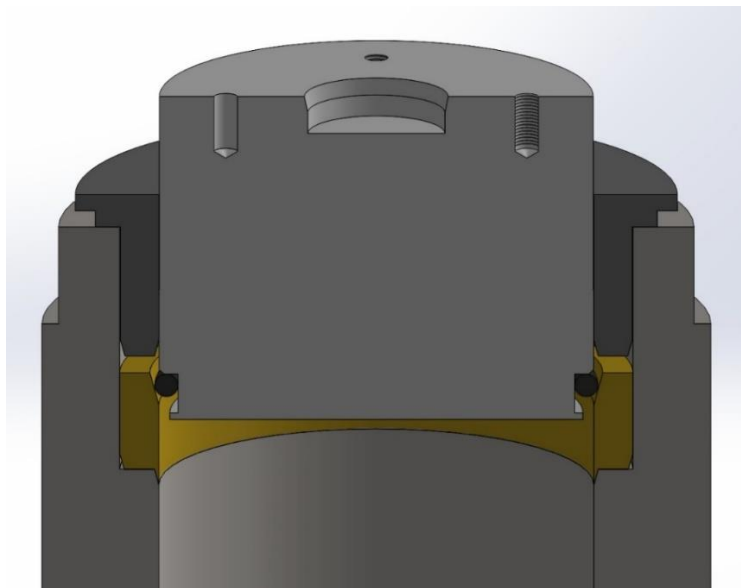

- Insert the insert sleeve for the O-ring with a larger taper into the top of the oil cylinder, grease the taper of the sleeve with Molykote M-55 sufficient
- Make sure, that it sits inside the short taper of the oil cylinder without any gap

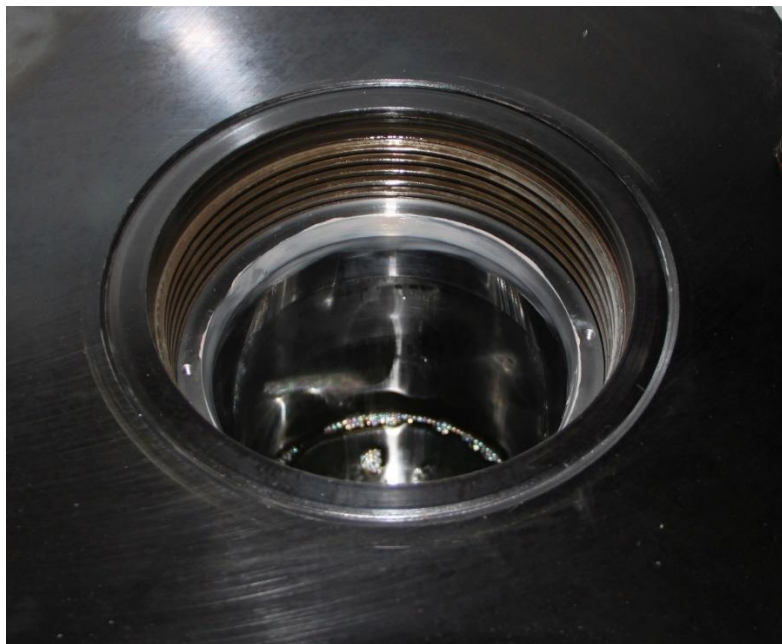
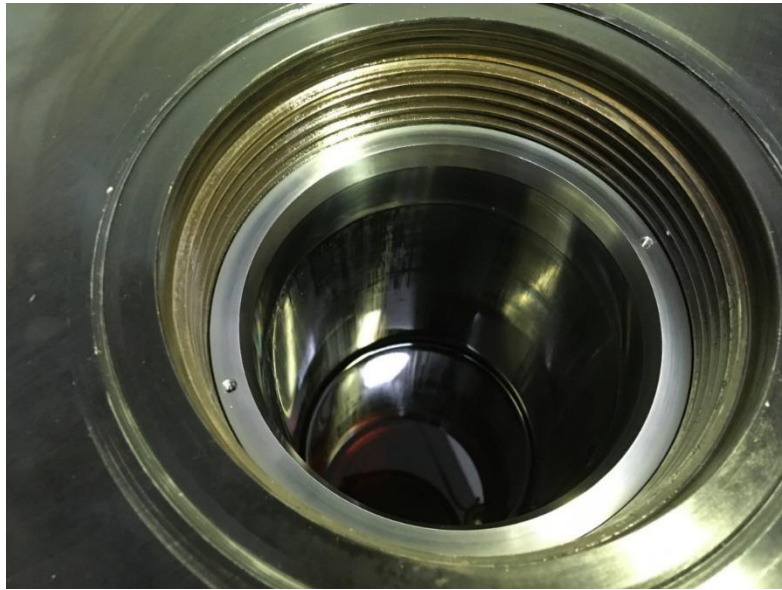

- Position the oil piston on top of the oil cylinder
- Make sure, that the oil piston is horizontal and concentric to the oil cylinder bore
- Make sure, that the o-ring, the mitre-ring and the back-up-ring (if installed) are concentric to the oil piston and the oil cylinder
- Unscrew and remove the two screws
- **It is not possible to push the oil piston into the oil cylinder manually with its own weight due to the very tight fit of the O-ring**
- Push the guide sleeve above the oil piston and insert it into the thread of the oil cylinder (the piston is not shown in the foto)
- Make sure, that this ring sits right in the thread at the top of the oil cylinder and is centering the oil piston

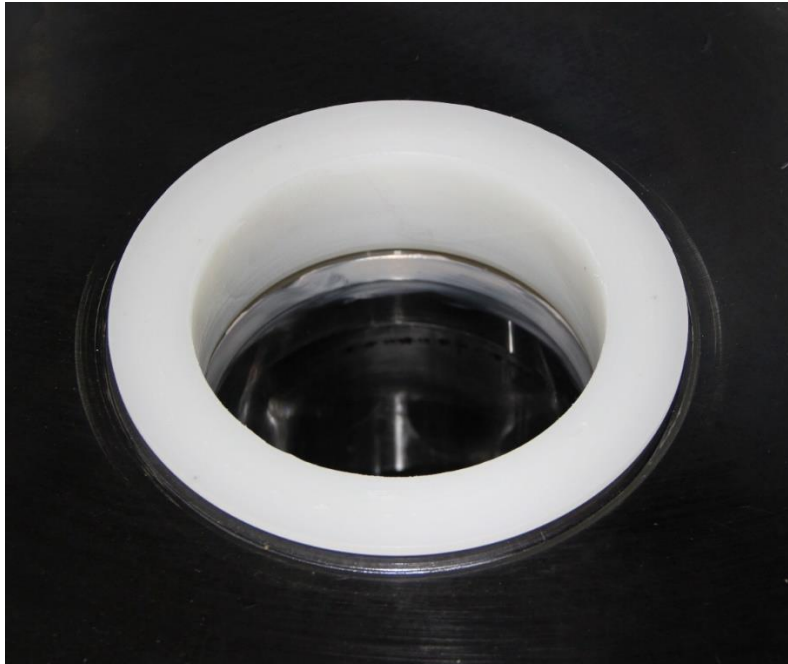

○

- Position the appropriate tool (aluminium cylinder) on top of the oil piston, **make sure that its fits perfect into the seat of the gas piston**

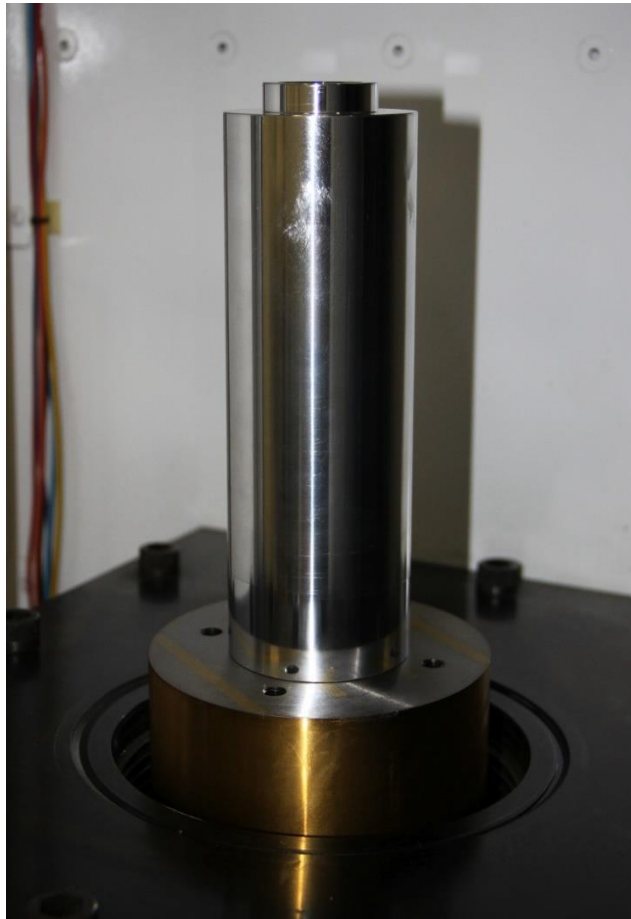

- Lower the gas cylinder with the hoist carefully until the top end of the tool slides into its borehole, **make sure that the tool fits perfect and that the gas cylinder does not tilt**

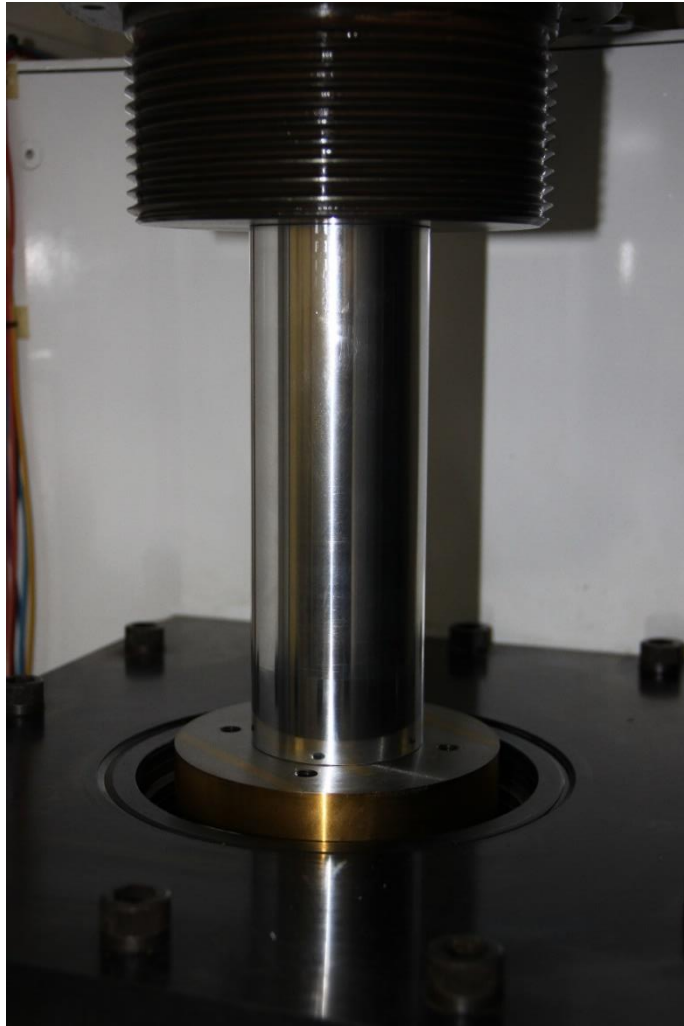

- Continue lowering the gas cylinder until oil escapes out of the vent bore
- Raise the gas cylinder with the hoist again
- Remove the tool from the oil piston
- Insert the valve ball into the vent bore
- Screw the vent screw and tighten it
- Insert the gas piston into the gas cylinder (described in section 9.4.1.)
- Lower the gas cylinder carefully until the gas piston touches the oil piston, **make sure it fits perfect into its seat**

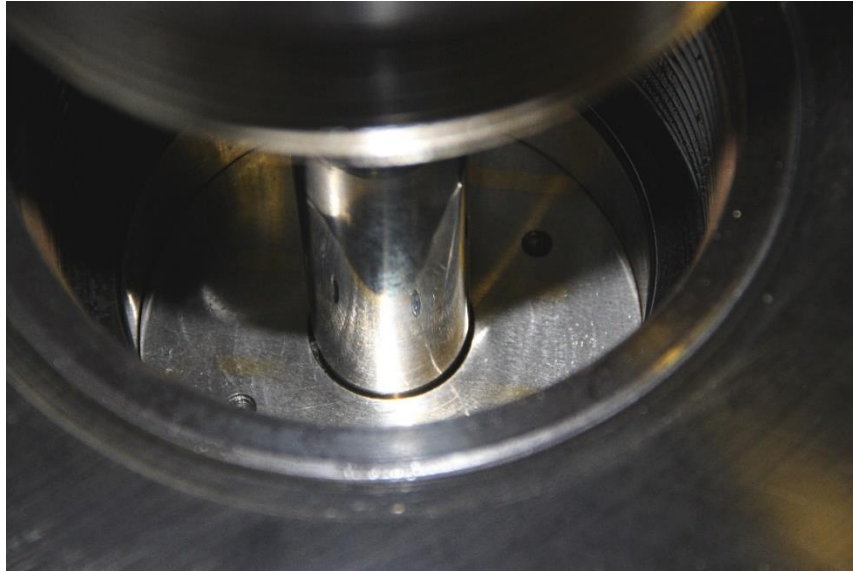

- Continue lowering the gas cylinder with the hoist until the threads start to mesh
- Screw the gas cylinder into the thread of the oil cylinder meanwhile continuously lowering the gas cylinder with the hoist
- Near full engagement continue slowly, **be careful not to tighten the thread, keep it loose**
- Remove the coupling of the hoist
- Connect the gland nut to the top of the intensifier and tighten it
- Tighten the loose gland nut at the tee
- Open the valves of the gas supply gently to push the pistons down to the bottom of the oil cylinder

9.5. Change of O-Rings – Volumometer

- Release all gas out of the pore pressure system
- Disconnect the plugs of the pore pressure sensor and the LVDT
- Unscrew and remove the cover of the LVDT
- Detach the core of the LVDT and remove it
- Remove the attachment bracket

- Unscrew the gland nut of the pore pressure line and remove it
- Unscrew and remove the blank plug at the volumometer
- Unscrew and withdraw the protective sleeve of the cylinder as far as possible
- Withdraw the cylinder

- Check the piston for any scratches or damages
- Clean the piston with cotton wool and alcohol

- Unscrew the retaining nut at the cylinder
- Remove the seal sleeve with an appropriate tool

- Remove the O-ring inside the groove in the borehole of the cylinder with an appropriate tool
- Remove the O-ring and the Mitre-ring inside the seal sleeve
- Check the Mitre-ring and clean it
- Clean the seal sleeve and clean it with cotton wool and alcohol
- Clean the groove in the borehole of the cylinder with cotton wool and alcohol

- Insert a new O-ring 012 (NBR 70) inside the groove in the borehole in the cylinder, grease the O-ring with Molykote M-55 slightly
- Insert the Mitre-ring into the seal sleeve followed by a new O-ring 803 (NBR 70), grease the O-ring with Molykote M-55 slightly
- Grease the taper at the end of the sea sleeve slightly with Molykote M-55
- Insert the seal sleeve into the cylinder
- Screw the retaining nut into the cylinder

- Push the cylinder into the protective sleeve
- Push both over the piston carefully
- Screw the protective sleeve and tighten it
- Attach the attachment bracket
- Attach the core of the LVDT
- Install the cover of the LVDT
- Connect the plugs to the pore pressure sensor and the LVDT
- Open the pore pressure connection valve gently

Part D: Further technical Developments at GFZ Potsdam

1. Monobloc-Furnace (already described in chapter 7)

- First example of this type of furnace assembled and tested with good results
- **Advantage:** much easier repair of a furnace by replacing of the inner part (blue and grey) from the bottom without disassembling the outer part (light brown)
- **Disadvantage:** quite complicate process of baking the cement

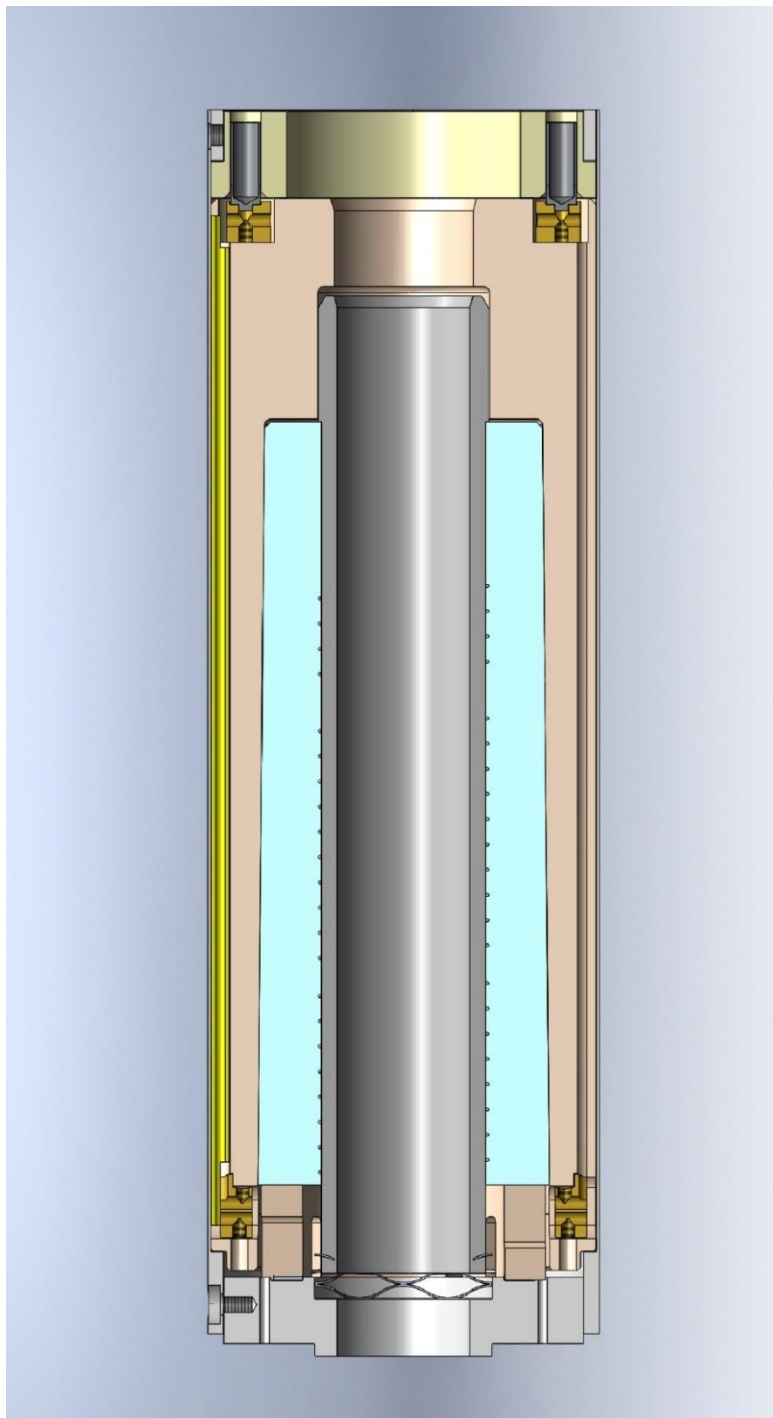

2. US-Measurement in creep, deformation & torsion experiments

2.1. US-Sensor (bottom) – inside internal load cell

- Manufactured and installed in the internal load cell of one machine
 - Tested and “calibrated” at different confining pressures with and without a running furnace and corrected for the piston assembly (not yet completely)
 - **Advantage:** permanent electrical contact of the sensor to the amplifier (soldered)
 - **Disadvantage:** no initial mechanical contact to the specimen assembly (spring load)
 - **Disadvantage:** sensor located far away from the sample
 - **Disadvantage:** complicate repair of the sensor
- ➔ Refer also to chapter 9.2.3.4. and 9.2.4.2.

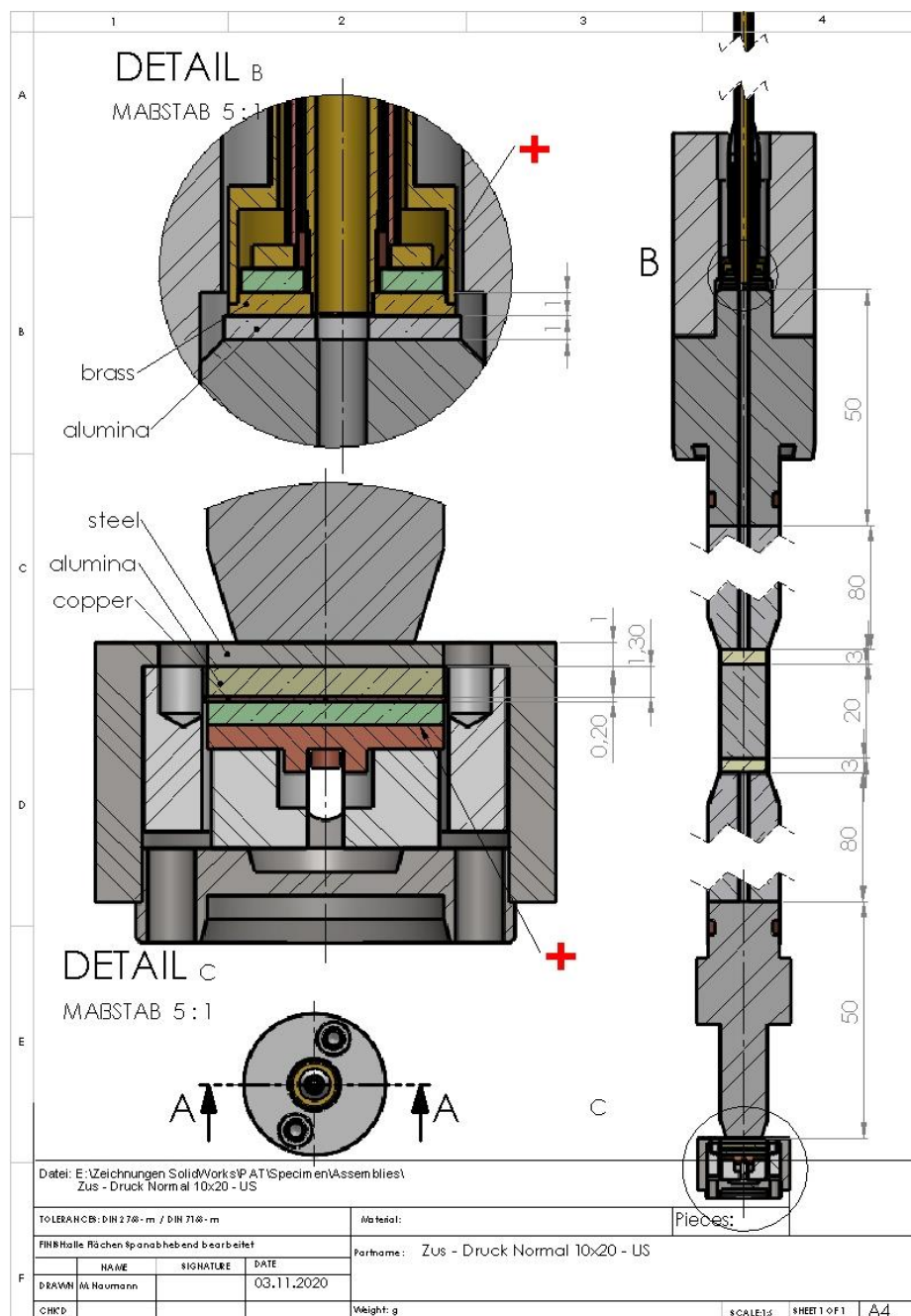

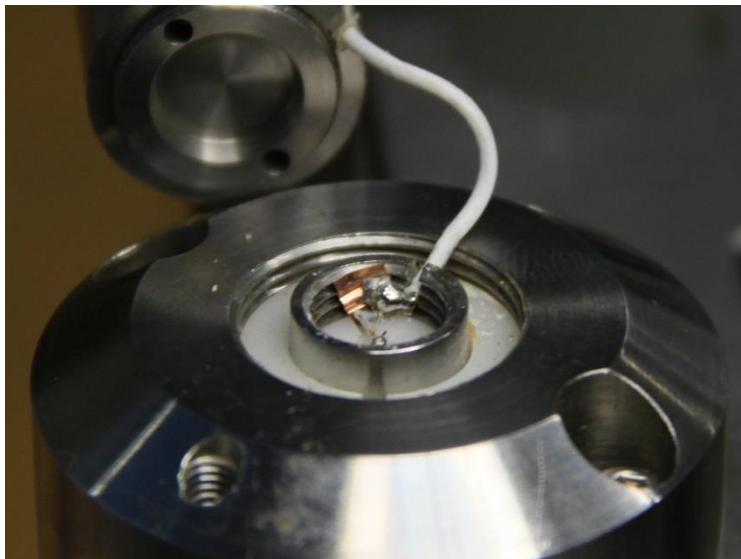

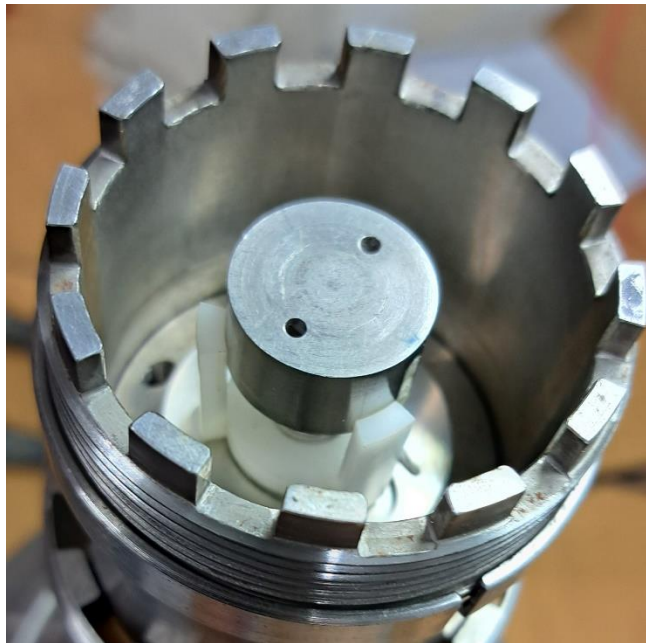
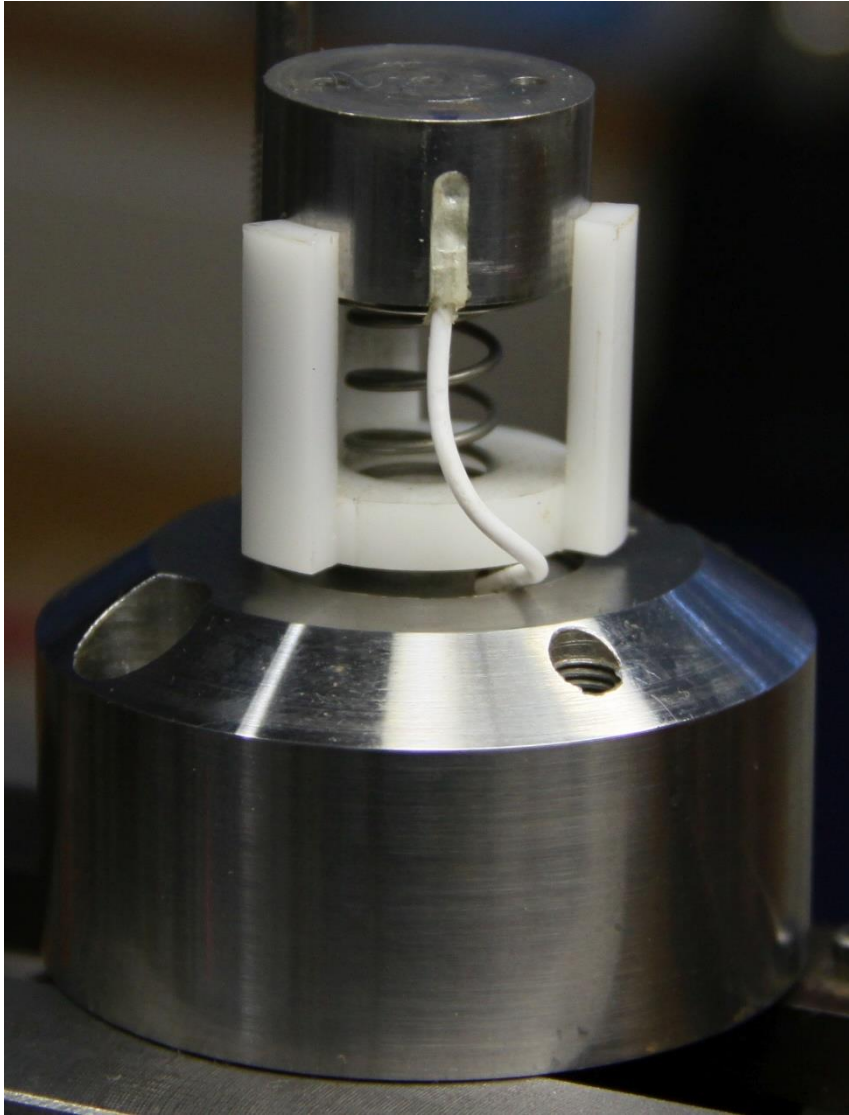

2.2. US-Sensor (bottom) – inside specimen bottom plug

- Design finished, manufacture in progress
- **Advantage:** sensor as a part of the specimen assembly, initial mechanical contact
- **Disadvantage:** no permanent electrical contact to the amplifier, coaxial plug/socket
- **Disadvantage:** sensor located far away from the sample

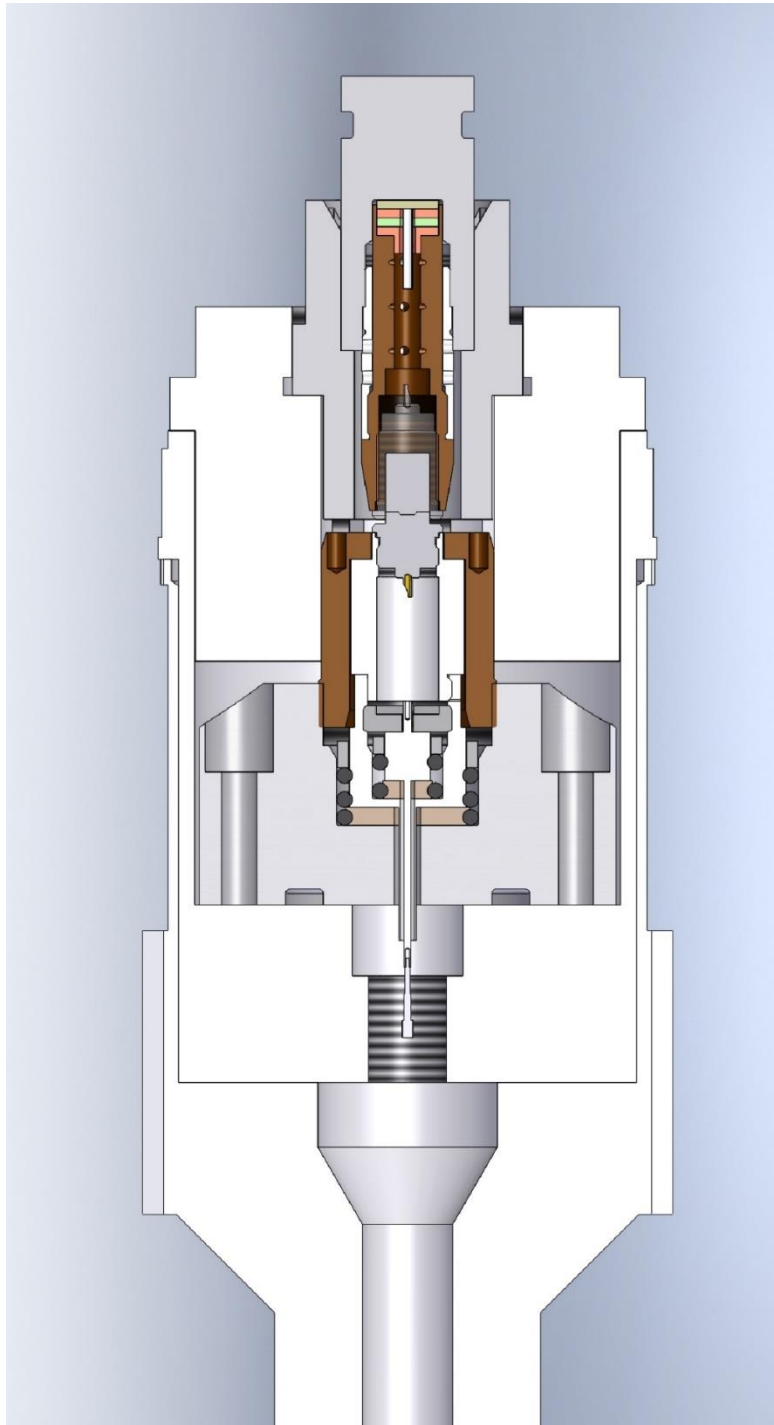

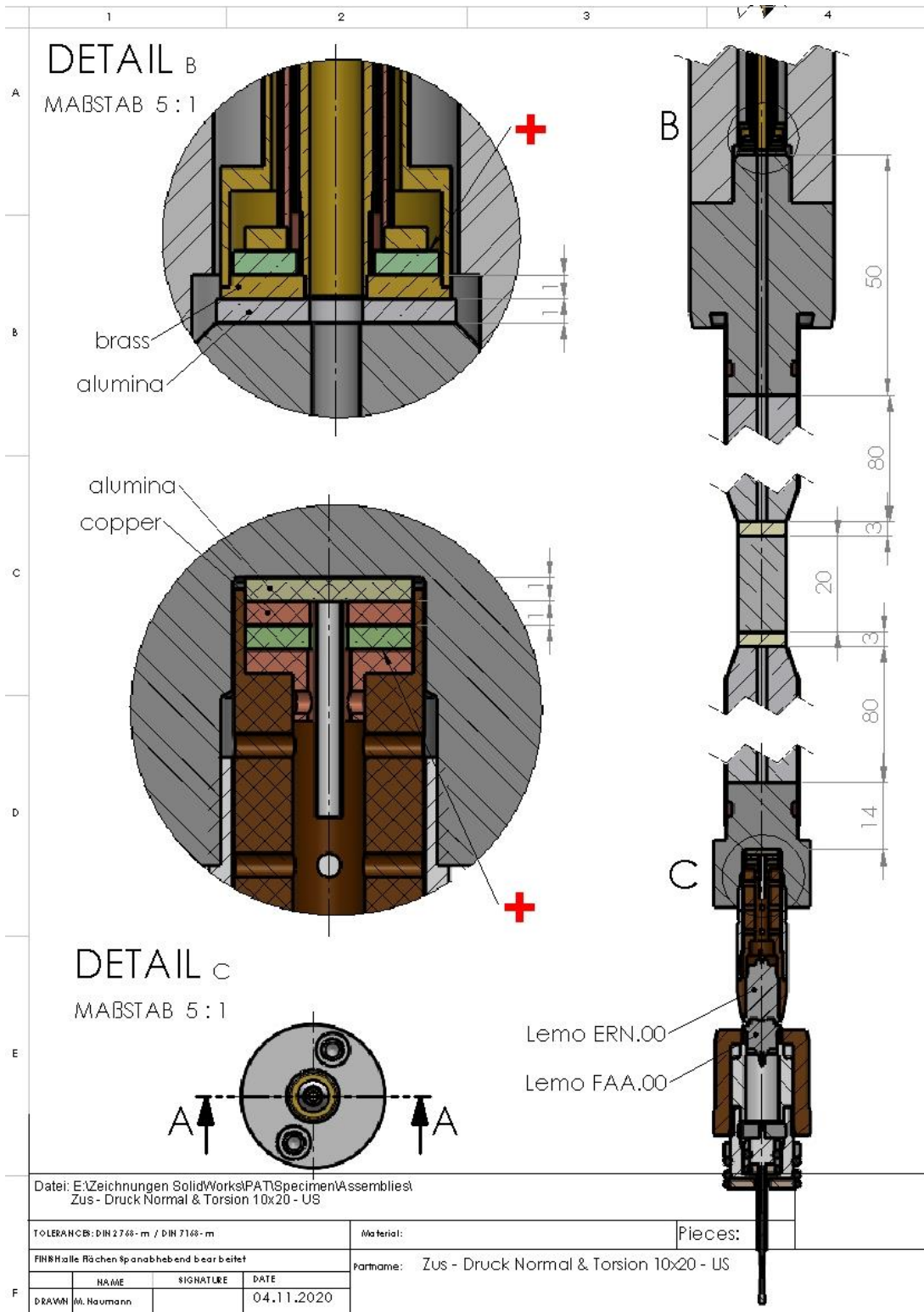

2.3. US-Sensor in specimen top plug – one single ring

- Manufactured and installed in a specimen top plug
- Tested and calibrated at different confining pressures with and without a running furnace and corrected for the piston assembly (not yet completely)
- **Advantage:** sensor is not exposed to pressure and high temperature
- **Disadvantage:** sensor located far away from the sample

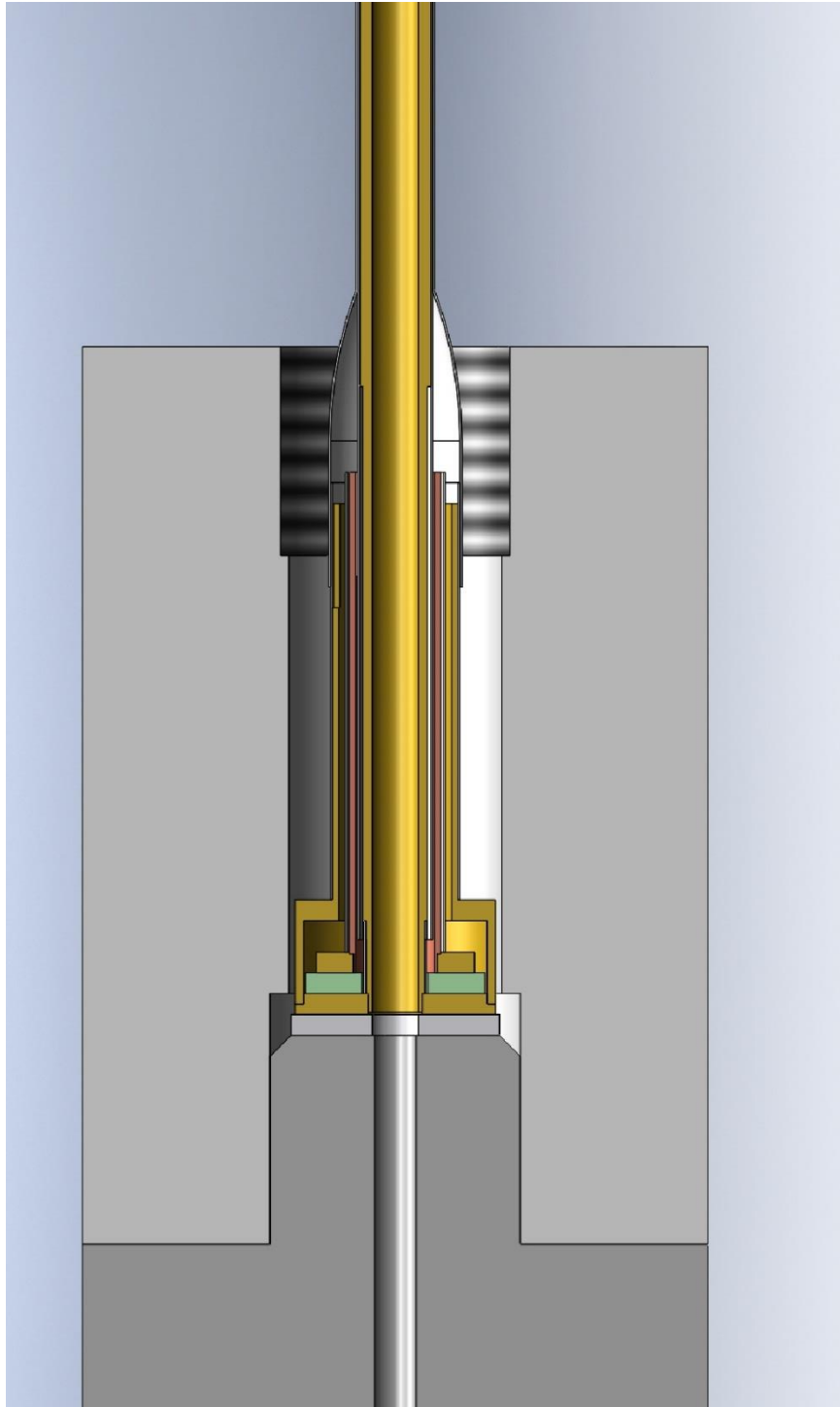

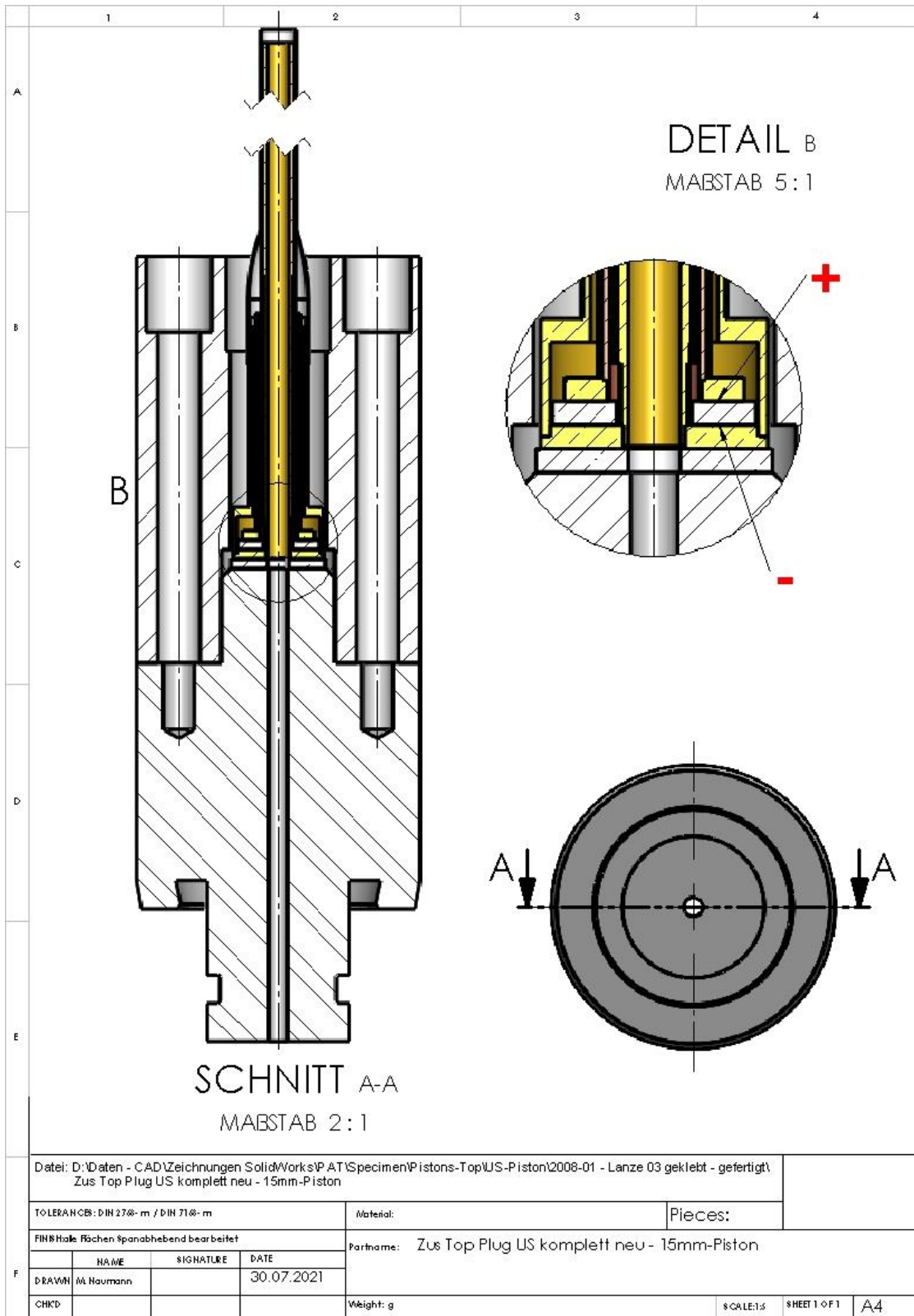

2.4. US-Sensor in specimen top plug – two concentric rings

- Manufactured and installed in one specimen top plug
- Only tested ones and not calibrated yet
- **Disadvantage:** small piezos, crosstalk (???)
- **Disadvantage:** sensor located far away from the sample

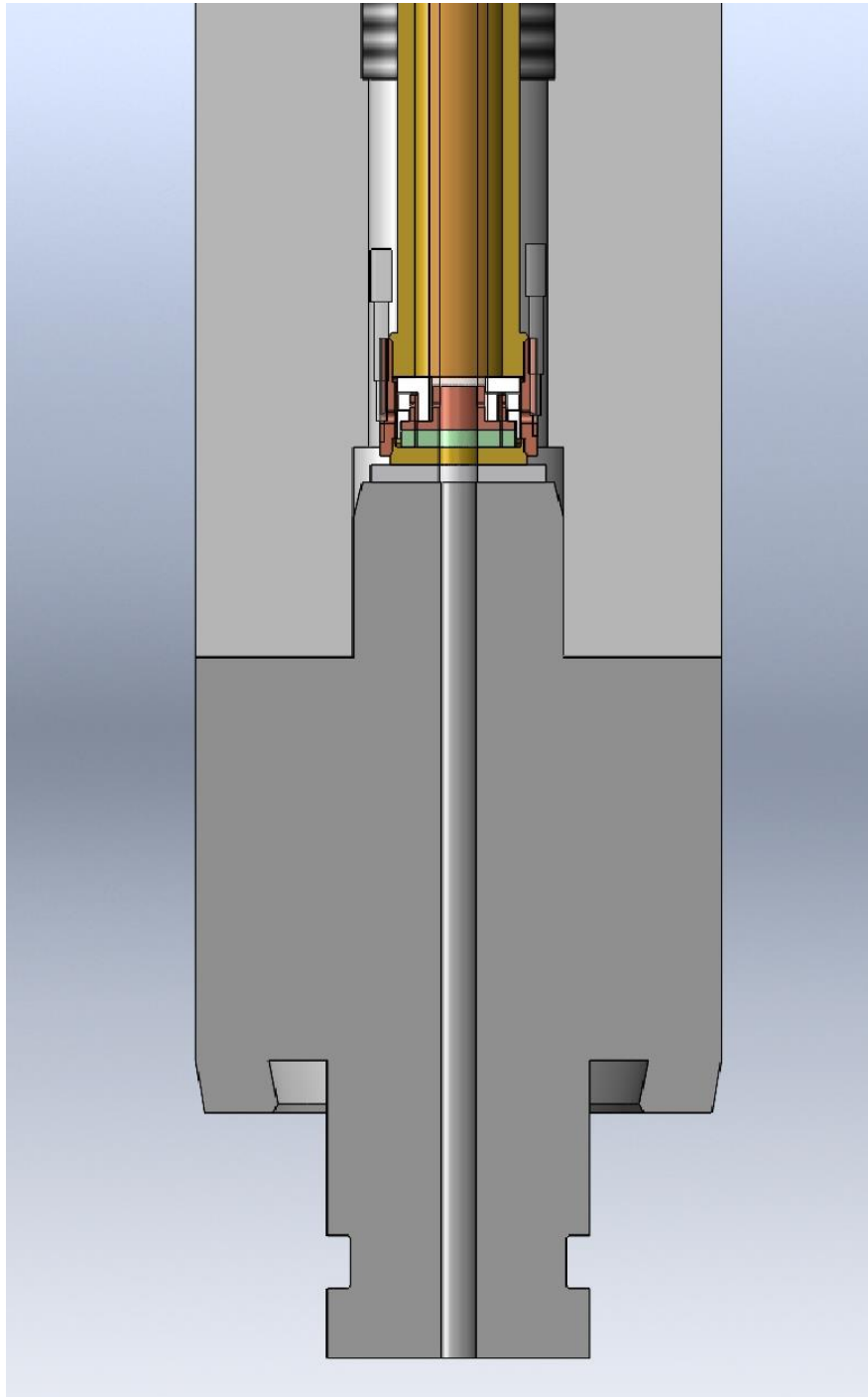

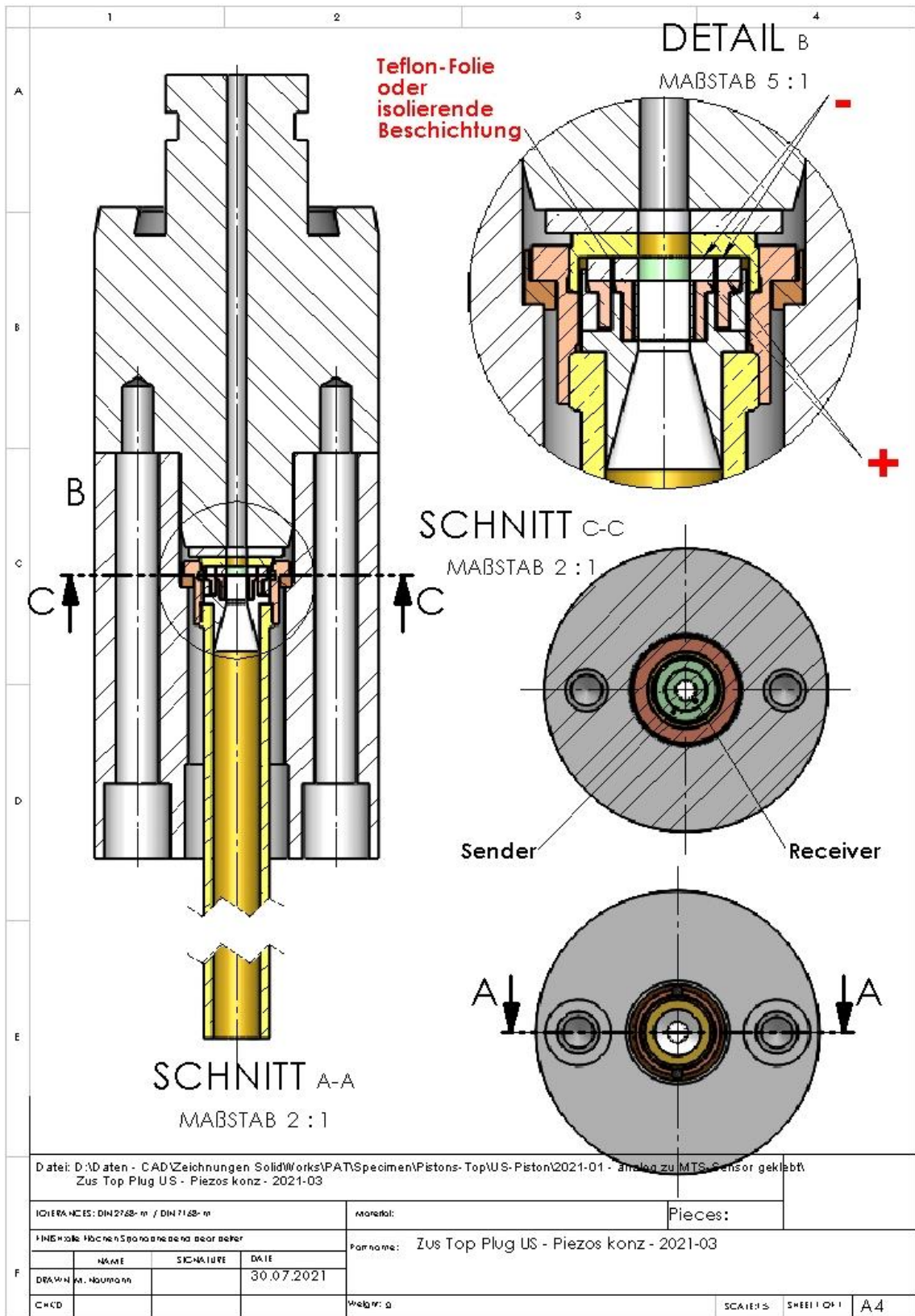

2.5. US-Sensor in specimen top plug – two half rings

- Design finished
- **Advantage:** sensor and receiver for wave-reflection measurement
- **Disadvantage:** small piezos, crosstalk (???)
- **Disadvantage:** sensor located far away from the sample

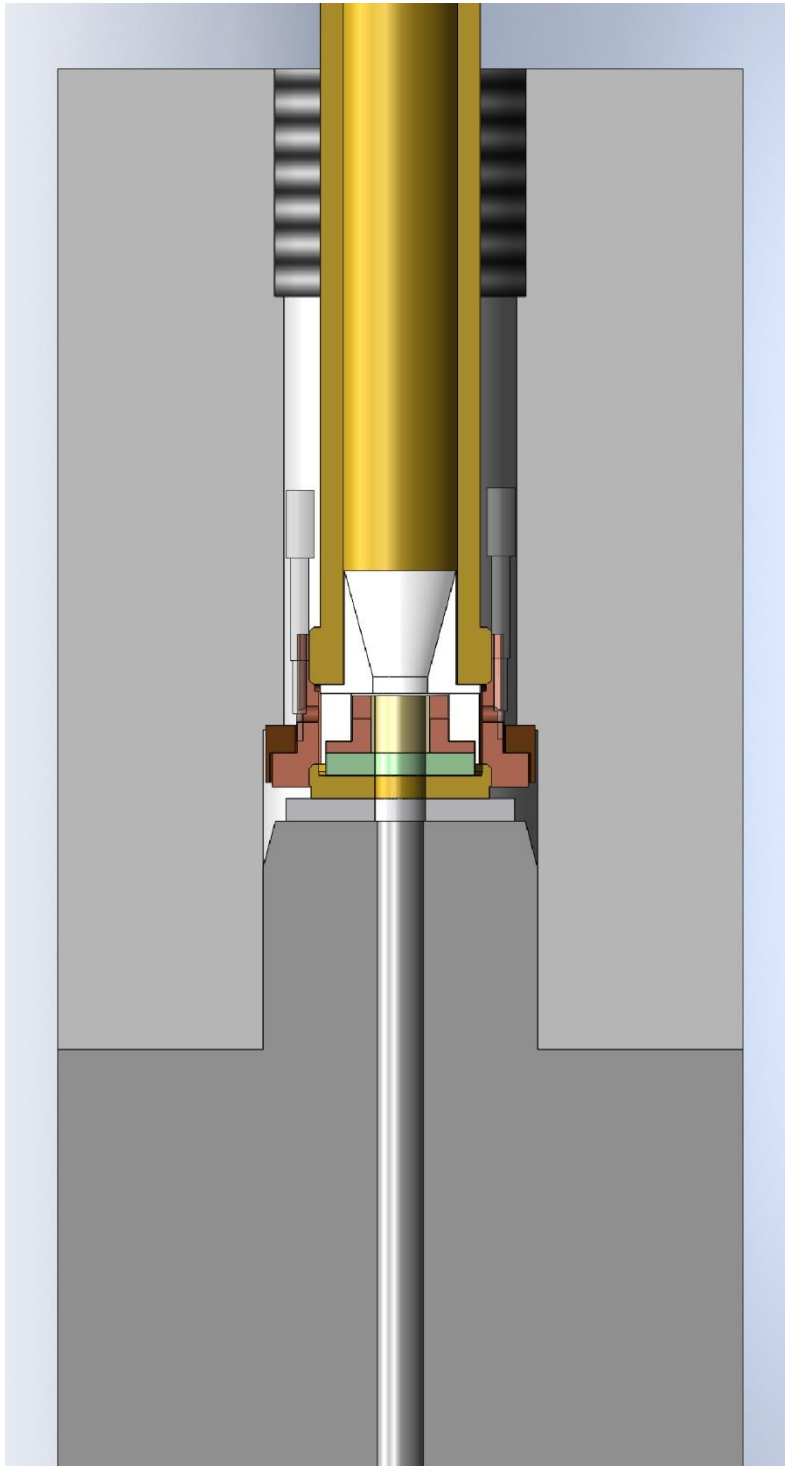

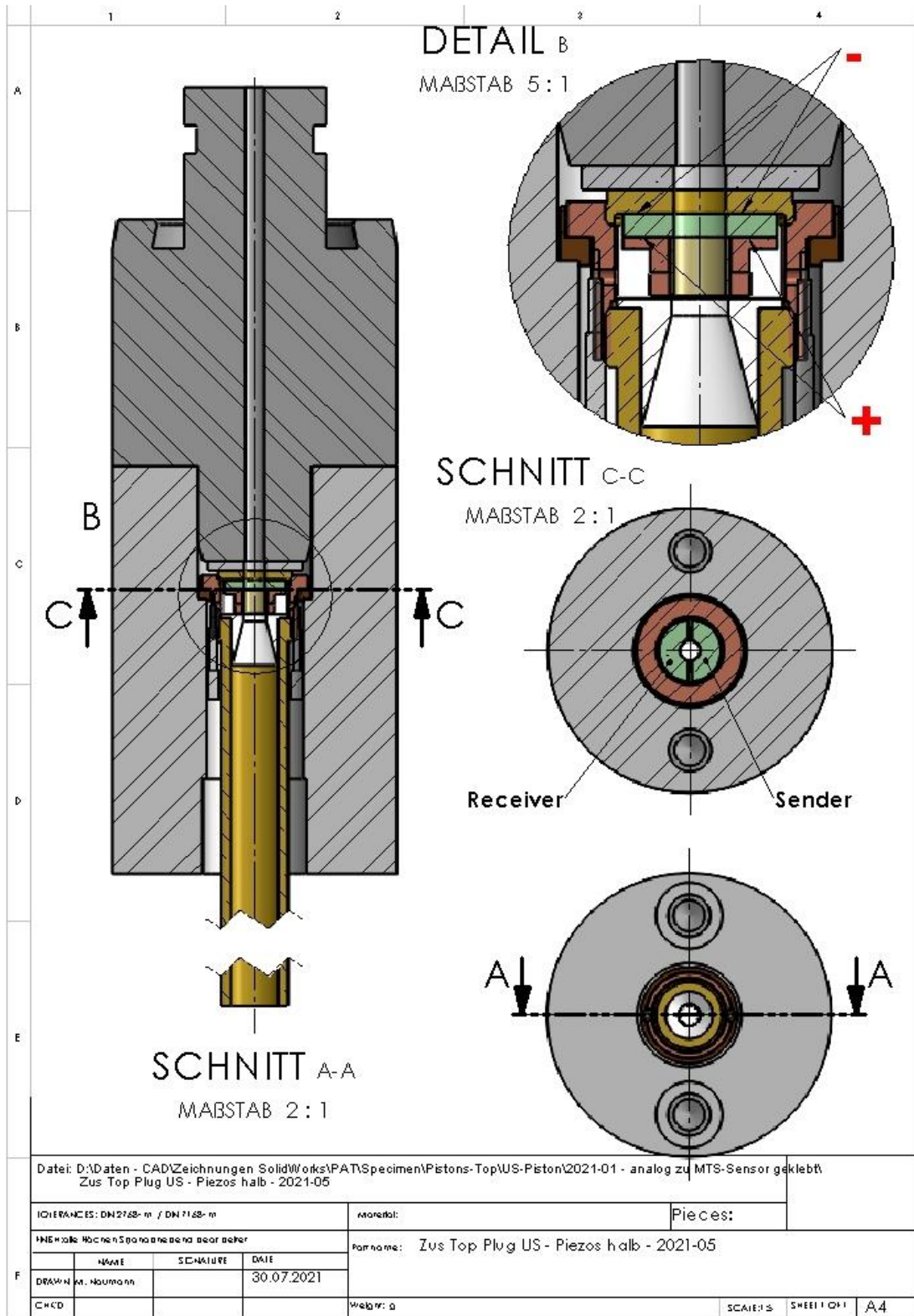

3. Internal load cell with ball bearing

- Design in progress with cylindrical roller bearing (Nadella AR 7 20 35)
- **Advantage:** reduction of cross-talk between axial load and torsion signal
- **Disadvantage:** axial load limited to 54 kN

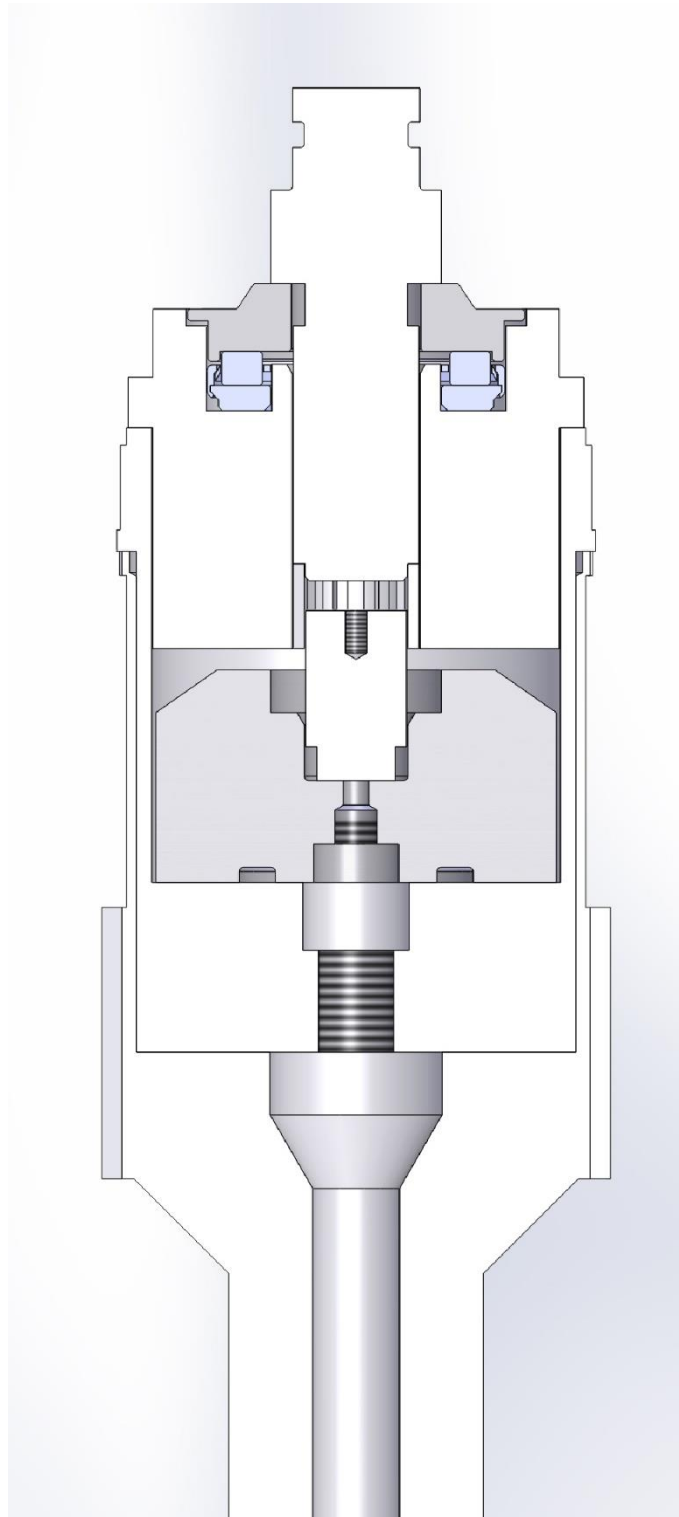

4. Internal load cell with separation of torque and axial load

- Design in progress with separate deformation bodies for axial load and torsion and with different cylindrical roller bearings (Nadella)
- **Advantage:** reduction of cross-talk between axial load and torsion signal
- **Disadvantage:** axial load limited to 70 kN (AR 7 25 42) or 54 kN (AR 7 20 35)

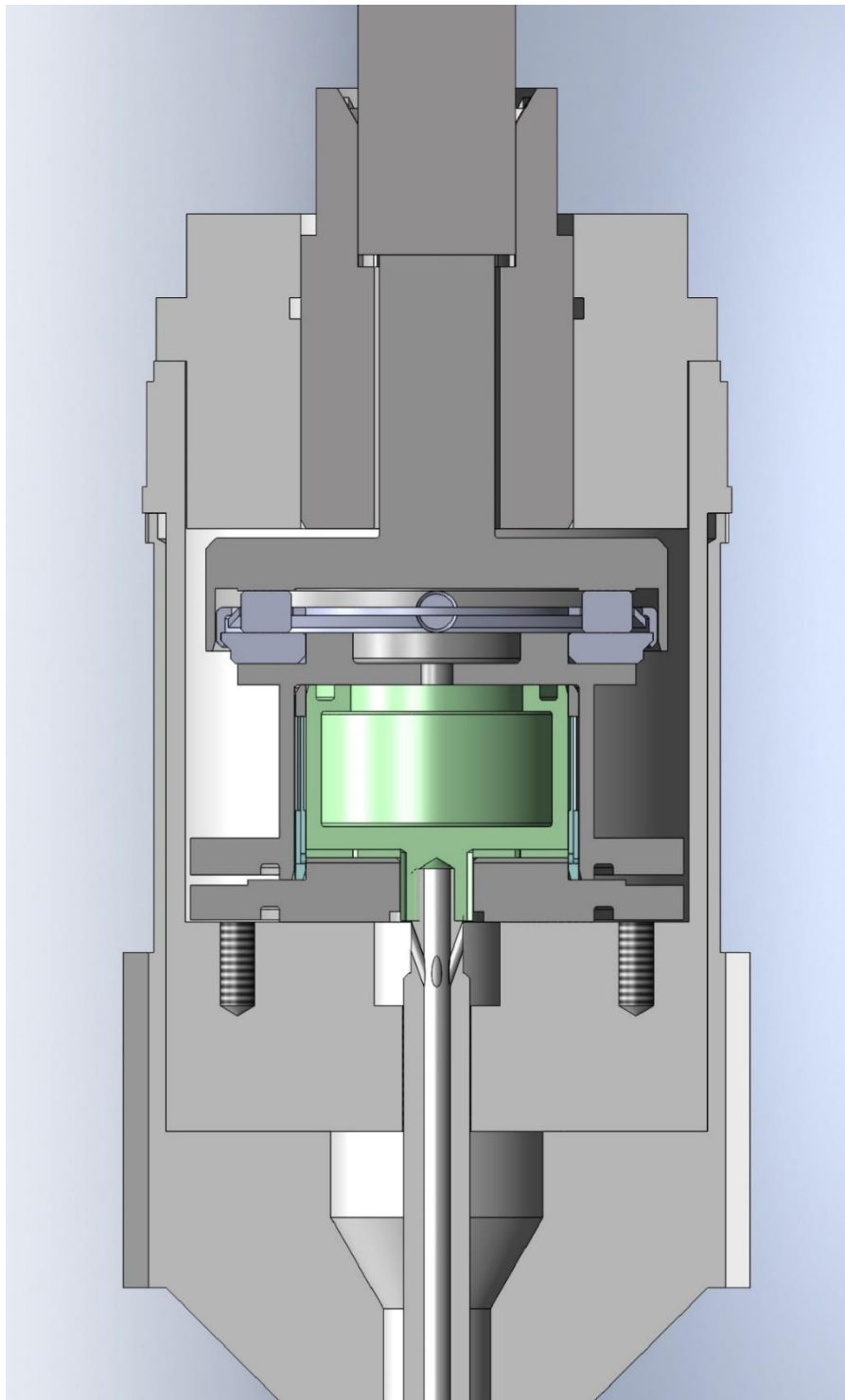

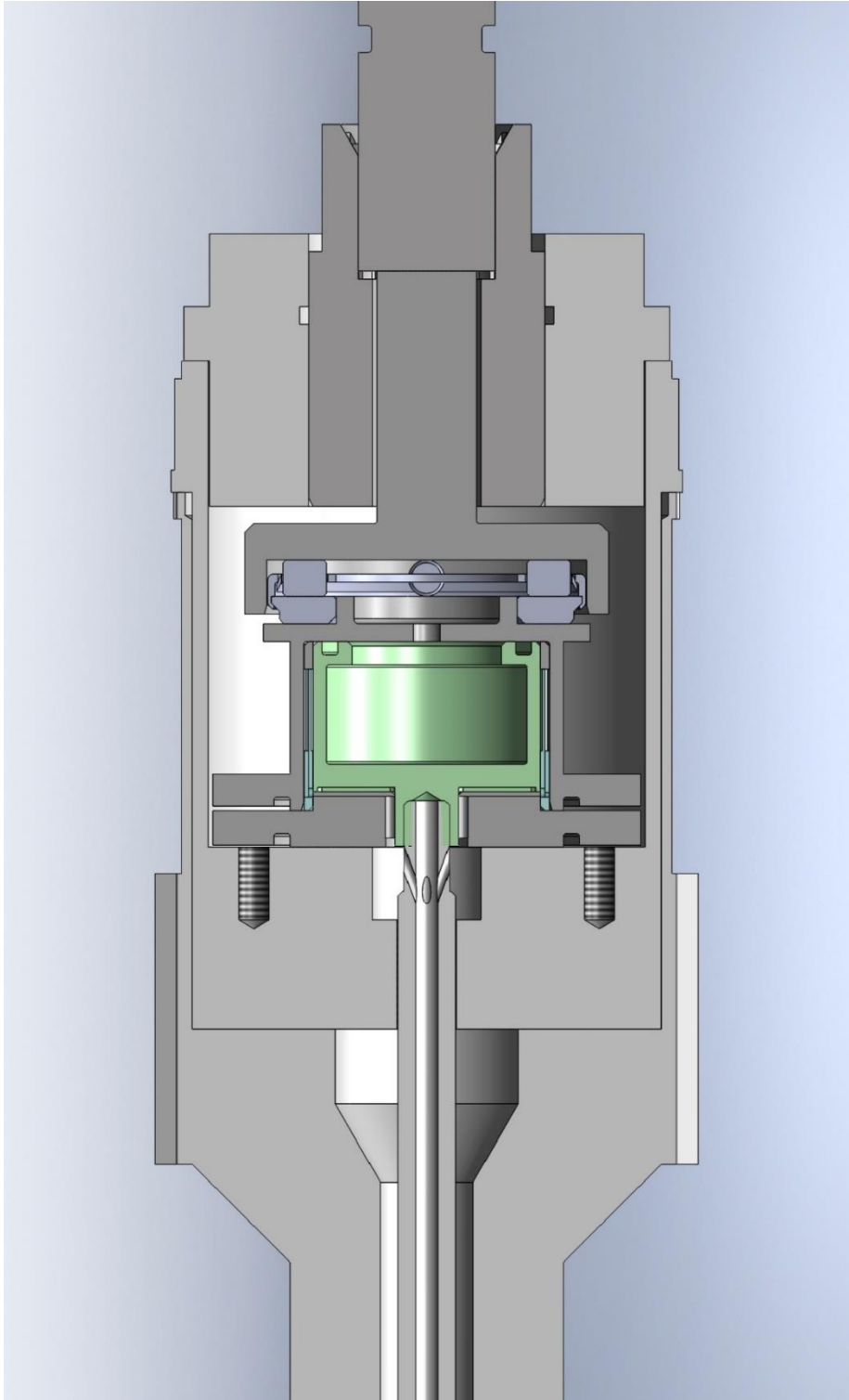

Appendix A : Kalibrierung ILC (+/-100 kN)

SPRING (Federkonstante – Cf = 10,81 kN/mm) :

1. ILC-Signal im DELPHIN mittels Zero-Poti am AD-3B18 auf **0,0 V** einstellen
2. Deformieren der Feder um den Weg **X_o** → ILC-Cal-1

$$X_o = 50 \text{ kN} / C_f$$

$$X_o = 4626 \text{ } \mu\text{m}$$

3. ILC-Signal im DELPHIN mittels Span-Poti am AD-3B18 auf **5,0 V** einstellen
(Bei nicht exakt erreichter Deformation entsprechende Spannung einstellen.)

SOLID :

4. Belasten bis auf Kraft ILC-Signal **5,0 V** → ILC-Cal-1
5. Ermitteln des Weges **Y** und der Steifigkeit der Kammer und Stempel sowie des Solid **1/Ck**

$$1/C_k = Y / 50 \text{ kN}$$

→ Die Feder ist somit tatsächlich nur um den Weg **Z = X_o - Y** deformiert worden, der Rest ist Kammerdehnung sowie Stauchung des Stempel und der Top Plug.

6. Die Federkonstante des Gesamtsystems **Cges** liegt somit bei

$$1/C_{ges} = (1/C_f + 1/C_k) = \text{___} \text{ mm/kN}$$

$$C_{ges} = \text{___} \text{ kN/mm}$$

7. Die Gesamt-Federkonstante liegt z.Z. bei

$$C_{ges} = 10,05 \text{ kN/mm}$$

SPRING :

8. Deformieren der Feder um den Weg **X_o + Y** → ILC-Cal-1 (ILC-Cal-2)
9. ILC-Signal im DELPHIN mittels Span-Poti am AD-3B18 auf **5,0 V** einstellen.

Check - Kalibrierung ILC

SPRING (Federkonstante - Cf = 10,81 kN/mm) :

Deformieren der Feder bis ca. 50 kN (3 Zyklen) → [ILC-Cal-2](#)

ORIGIN : Graph

$$\text{ILCmVnull [mV]} = f(\text{YDCDTnull [\mu m]})$$

Steigung durch linearen Fit ermitteln

$$m = \text{_____ mV/mm}$$

Tabelle → neue Spalte „ILCcalc [kN]“, rechnen

$$\text{Col(ILCmVnull)} * C_{ges} : m$$

Tabelle exportieren in ASCII

EXCEL :

Nur Spalten **ILCmVnull** und **ILCcalc** verwenden, Rest löschen

Spalten ergänzen um rechnerische Werte für -10V bzw. +10V

Datei als Tabelle im Busmanager in Linearisierung für Kanal **ILC – Lin-300** importieren

SPRING :

Deformieren der Feder bis ca. 50 kN (2...3 Zyklen) → [ILC-Cal-2](#)

ORIGIN : Graph

$$\text{ILCnull [kN]} = f(\text{YDCDTnull [\mu m]})$$

Steigung durch linearen Fit ermitteln – derzeit **SOLL**

$$\begin{aligned} 1/C_{ges} &= (1/C_f - 1/C_k) = 9,92 \text{exp-4 mm/kN} \\ C_{ges} &= 10,08 \text{ kN/mm} \end{aligned}$$

Appendix B : Deformation Kammer & Solid Body

Kalibrierung No.4 (2005-03-22):

Mehrfaches Belasten des Solid Body von ca. 3kN (Touch Point) um 50kN

Gemessene „Deformation“ [μm] für die einzelnen Belastungen

1. 340
2. 336
3. 344
4. 324
5. 337

Differenz [μm] 20
Mittelwert [μm] 336,2

Ergibt eine Gesamt-Steifigkeit [$\mu\text{m}/\text{kN}$] von **6,72**

Kalibrierung No.7 (2006-03-14):

Mehrfaches Belasten des Solid Body von ca. 3kN (Touch Point) um 50kN

Gemessene „Deformation“ [μm] für die einzelnen Belastungen

1. 343
2. 322
3. 317
4. 316
5. 327

Differenz [μm] 27
Mittelwert [μm] 325,0

Ergibt eine Steifigkeit [$\mu\text{m}/\text{kN}$] von **6,50**

Appendix C : Kalibrierung ITC (+/-160 Nm)

SMALL (d = 15mm / G = 83GPa):

8. ITC-Signal im DELPHIN mittels Zero-Poti am AD-3B18 auf **0,0V (= 0Nm)** einstellen
9. Deformieren des Stabes um Moment **M = 5,0V = 5,5V – 0,5V** (80Nm = 88Nm - 8Nm)
10. Messen des Winkels **$\Theta(\text{sm8})$** und **$\Theta(\text{sm88})$** , Ermitteln **$\Theta(\text{sm80})$**

BIG (d = 26mm / G = 83GPa):

11. Deformieren des Stabes um Moment **M = 5,0V = 5,5V – 0,5V** (80Nm = 88Nm - 8Nm)
12. Messen des Winkels **$\Theta(\text{bm8})$** und **$\Theta(\text{bm88})$** , Ermitteln **$\Theta(\text{bm80})$**

Rechnen :

$$M = 2,053 [\Theta(\text{sm80}) - \Theta(\text{bm80})]$$

→ Moment sollte **80Nm = 5,0V** entsprechen

Rechnen :

$$\Theta(\text{sm88}) = \Theta(\text{st80}) + \Theta(\text{sm8}) + \Theta(\text{bm80}) - \Theta(\text{bt80})$$

SMALL :

6. Deformieren des Stabes um den berechneten Winkel **$\Theta(\text{sm88})$**
7. Einstellen des Momentes **M = 5,5V (= 88Nm)** mittels Span-Poti am AD-3B18
8. Nochmals deformieren um Moment **M = 5,0V = 5,5V – 0,5V** (80Nm = 88Nm – 8Nm)
9. Messen des Winkels **$\Theta(\text{sm8})$** und **$\Theta(\text{sm88})$** , Ermitteln **$\Theta(\text{sm80})$**

BIG :

10. Deformieren des Stabes um Moment **M = 5,0V = 5,5V – 0,5V** (80Nm = 88Nm – 8Nm)
11. Messen des Winkels **$\Theta(\text{bm8})$** und **$\Theta(\text{bm88})$** , Ermitteln **$\Theta(\text{bm80})$**

Rechnen :

$$M = 2,053 [\Theta(\text{sm80}) - \Theta(\text{bm80})]$$

→ Moment sollte **80Nm = 5,0V** (besser) entsprechen

Gegebenenfalls nochmals wiederholen.

Check Kalibrierung ITC

SMALL (d = 15mm / G = 83GPa):

1. ITC-Signal im DELPHIN mittels Zero-Poti am AD-3B18 auf **0Nm** einstellen
2. Deformieren des Stabes um Moment **M = 100Nm** (2...3 Zyklen)

BIG (d = 26mm / G = 83GPa):

3. Deformieren des Stabes um Moment **M = 100Nm** (2...3 Zyklen)

ORIGIN :

4. Ermitteln Twist-Differenz (graphisch!) für theoretische Drehmomente – TwistDIFF
5. Ermitteln Twist-Differenz (graphisch!) für gemessene Drehmomente – RVDTDIFF

Langname	TorqueTheor(X1)	TwistROD15(Y1)	TwistROD26(Y1)	TwistDIFF(Y1)	E1(Y1)	ITCnullROD15(X2)	RVDTnROD15(Y2)	ITCnullROD26(X3)	RVDTnROD26(Y3)	A(X4)	RVDTDIFF(Y4)
Einheiten	Nm	mrad	mrad	Math Y1		Nm	mrad	Nm	mrad	Math X1	Math Y2
Kommentare				Subtracted by TwistROD26 on TwistROD15				ITCnullROD26 Template "CUT"	RVDTnROD26 Template "CUT"		Subtracted by RVDTnROD26 on RVDTnROD15
F(x)=	brqueTheor*27,7355/brqueTheor*27,7355/4:										
1	10	5,47852		4,87159		5,326	4,808	5,592	5,054	5,326	-0,36267
2	20	10,95704		9,74319		5,828	4,96	6,26	4,761	5,828	0,00951
3	30	16,43556		14,61478		6,391	5,701	7,018	5,301	6,391	0,84668
4	40	21,91407		19,48638		7,015	5,986	7,834	5,302	7,015	0,88714
5	50	27,39259		24,35797		7,529	6,351	8,621	5,37	7,529	1,04937
6	60	32,87111		29,22956		8,065	6,733	9,443	5,762	8,065	1,41104
7	70	38,34963		34,10116		8,601	6,604	10,362	5,852	8,601	1,23573
8	80	43,82815		38,97275		9,212	7,287	11,308	5,895	9,212	1,63516
9	90	49,30667		43,84434		9,814	7,723	12,393	6,54	9,814	1,92467
10	100	54,78519		48,71594		10,387	8,237	13,303	6,37	10,387	2,38466
11	110	60,26371		53,58753		10,94	8,528	14,439	6,912	10,94	2,66806
12	120	65,74222		58,45913		11,573	8,971	15,593	7,05	11,573	2,94114
13	130	71,22074		63,33072		12,122	9,114	16,714	7,018	12,122	2,74259
14						12,75	9,836	18,056	7,055	12,75	3,36269
15						13,383	10,175	19,327	7,857	13,383	3,805
16						13,889	10,303	20,428	8,108	13,889	3,65341
17						14,394	10,806	21,909	8,165	14,394	4,01547
18						15,112	11,371	23,325	8,258	15,112	4,37852
19						15,68	11,592	24,723	8,4	15,68	4,44448
20						16,251	11,642	26,36	8,494	16,251	4,61078
21						16,898	12,131	27,98	9,088	16,898	5,10793

6. Graph :

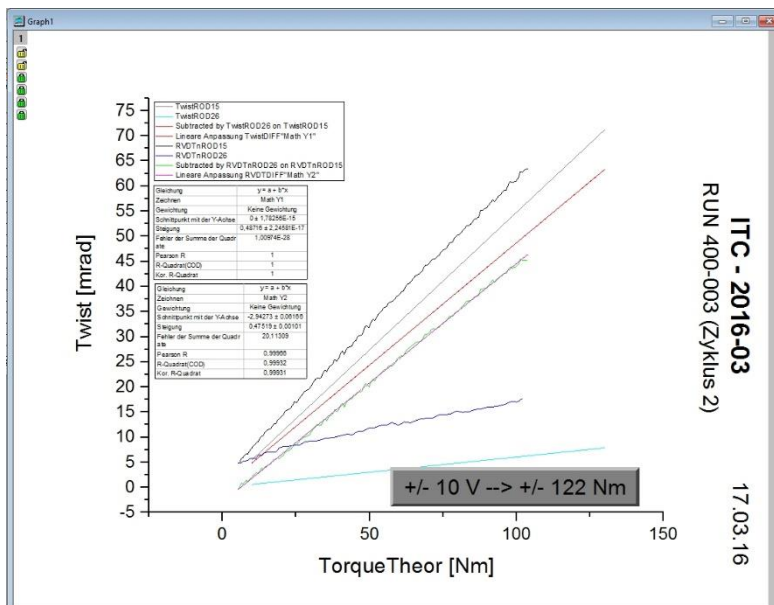



ISSN 2190-7110