

## Geothermal Binary Power Plant for Lahendong, Indonesia: A German-Indonesian Collaboration Project

Stephanie Frick<sup>1</sup>, Ali Saadat<sup>1</sup>, Taufan Surana<sup>2</sup>, Eben Ezer Siahaan<sup>3</sup>, Gina Andrea Kupfermann<sup>1</sup>, Kemal Erbas<sup>1</sup>, Ernst Huenges<sup>1</sup>, Mawardi A. Gani<sup>3</sup>

<sup>1</sup> GFZ Potsdam, Telegrafenberg, 14473 Germany

<sup>2</sup> BTMP-BPPT, Building No. 625, PUSPIPTEK, Serpong, Tangerang Selatan, 15314, Indonesia

<sup>3</sup> Pertamina Geothermal Energy, Head Office, MH. Thamrin No. 9, Jakarta 10340, Indonesia

[frick@gfz-potsdam.de](mailto:frick@gfz-potsdam.de), [saadat@gfz-potsdam.de](mailto:saadat@gfz-potsdam.de), [taufansurana@gmail.com](mailto:taufansurana@gmail.com), [eesiahaan@pertamina.com](mailto:eesiahaan@pertamina.com), [kupfer@gfz-potsdam.de](mailto:kupfer@gfz-potsdam.de), [erbas@gfz-potsdam.de](mailto:erbas@gfz-potsdam.de), [huenges@gfz-potsdam.de](mailto:huenges@gfz-potsdam.de), [mawardi.agani@pertamina.com](mailto:mawardi.agani@pertamina.com)

**Keywords:** Binary power plants, Indonesia, Lahendong, demonstration project

### ABSTRACT

In order to successfully demonstrate binary power plant technology at an Indonesian site, a German-Indonesian collaboration involving GFZ Potsdam (Germany), the Agency for the Assessment and Application of Technology in Indonesia (BPPT) and PT Pertamina Geothermal Energy (PGE) has been initiated. The demonstration power plant will be installed at the Lahendong geothermal field and commissioning is planned for the end of 2015. The experience from planning, installing, operating and optimizing this demonstration power plant should be transferred to other sites in Indonesia and should help to enable the deployment of binary power plants in the future. This contribution will give an overview on the project.

### 1. INTRODUCTION

Indonesia has a tremendous geothermal potential of around 27 GW. The currently installed capacity amounts to about 1.2 GW from 7 areas (Sukhyar et al. 2010). Two of the existing geothermal power plants are dry steam plants, which can directly and completely use the geothermal steam produced from the reservoir. 65 % of the installed geothermal capacity is based on single flash units, which use the vapor phase from the produced wet steam (DiPippo 2012). Geothermal binary power plants, which transfer the geothermal heat to a separate working fluid in order to convert thermal into kinetic energy, are not yet in operation. However, they could significantly extend the exploitable geothermal potential in Indonesia. On one hand, binary power plants can increase the plant capacity at wet steam fields since they can use the liquid phase from wet steam (Fig. 1, left). On the other hand, exploitation of low to intermediate temperature geothermal reservoirs and small scale geothermal power supply ranging from 50 kW to 5 MW would be possible (Fig. 1, right).

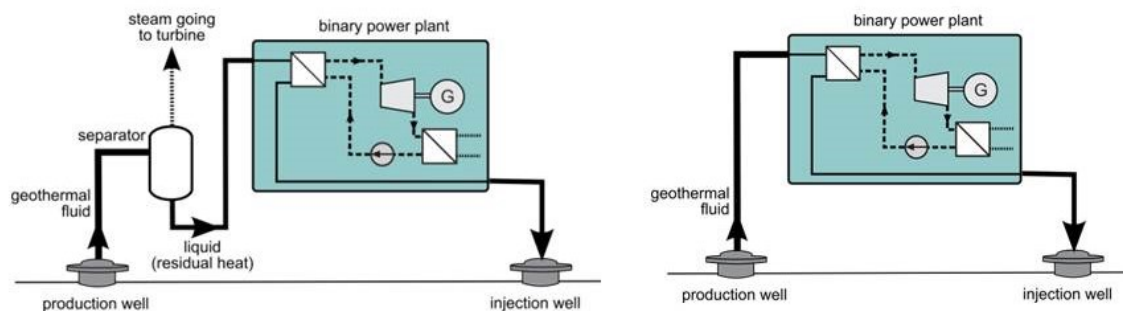

**Figure 1: Binary power plant at a high temperature geothermal using the liquid phase from the separator (left) and binary power plant using the heat from a low temperature geothermal reservoir (right)**

In order to successfully demonstrate binary power plant technology at an Indonesian site and to stimulate the development of this technology, a German-Indonesian collaboration involving GFZ Potsdam (Germany), the Agency for the Assessment and Application of Technology in Indonesia (BPPT) and PT Pertamina Geothermal Energy (PGE) has been initiated. The basis for this collaboration was established within the German-Indonesian cooperation project “Sustainability concepts for exploitation of geothermal reservoirs in Indonesia” which started in 2009. Since then, several research activities have been carried out in the field of integrated geosciences and fluid-chemistry (Erba et al. 2015). In the field of plant technology, the technical concept for a demonstration binary power plant at the Lahendong site has been elaborated. The realization of the demonstration binary power plant is carried out in a separate collaboration project which was officially granted in October 2013. The commissioning is planned for the end of 2015.

Within the following paragraphs general aspects of binary power plant technology as well as a brief description of the site and the project will be given.

### 3. GEOTHERMAL BINARY POWER PLANTS

Geothermal binary power plants can basically be divided into three technical subsystems: the geothermal fluid cycle, the power conversion cycle and the cooling system for the removal of the waste heat. The challenge in designing and operating geothermal binary power plants is to manage the efficient and reliable interaction of these technical subsystems at a specific site.

The **geothermal fluid cycle** carries the geothermal energy from the production well or separator to the power plant and from there to the injection well. Its reliability is therefore demanding for successful plant operation. The operational reliability is thereby strongly affected by interaction of the geothermal fluid with the plant materials as well as chemical processes triggered by temperature and pressure changes within the brine cycle. Especially scaling and corrosion are technical risks which need to be considered based on the particular fluid composition. Due to the large variability in site specific fluid composition, selection of suitable material and proper fluid treatment can be quite challenging, especially in case experience values and reliable data are not available. Further information can be retrieved from Huenges (2010).

In the **power conversion cycle**, a separate working fluid is heated and evaporated by the geothermal fluid. The vapor is expanded in an expansion machine connected to an electrical generator. In most applications turbines are used as expansion machines due to their wide application range and widespread availability. The exhaust vapour from the turbine is then re-condensed. Depending on the working fluid, the exhaust vapour can also be used for internal heat recuperation using a recuperator before condensation. Even though the recuperator will introduce additional pressure losses which increase the feed pump power, on the one side, and decreases the turbine output, on the other, it should be used with power-consuming cooling systems in order to reduce the waste heat removal and in case there are geochemical and reservoir related restrictions regarding the brine reinjection temperature.

Existing binary conversion cycles use different working fluids and cycle layouts. Referring to geothermal resources, the Organic Rankine Cycle (ORC), which uses an organic working fluid, is the most common type. At the moment more than 150 binary units with an average capacity between 0.05 and 5 MW are installed world-wide (DiPippo, 2012). The electrical power that can be produced from a binary conversion cycle depends on the heat source and heat sink characteristics, on component-specific parameters (such as component efficiencies and minimum temperature differences in heat exchangers) and the binary cycle design. Site-specific cycle design has to aim at a high utilization of the geothermal heat, however, considering geochemical and reservoir related restrictions. Further information can be retrieved from literature (DiPippo 2012, Huenges 2010).

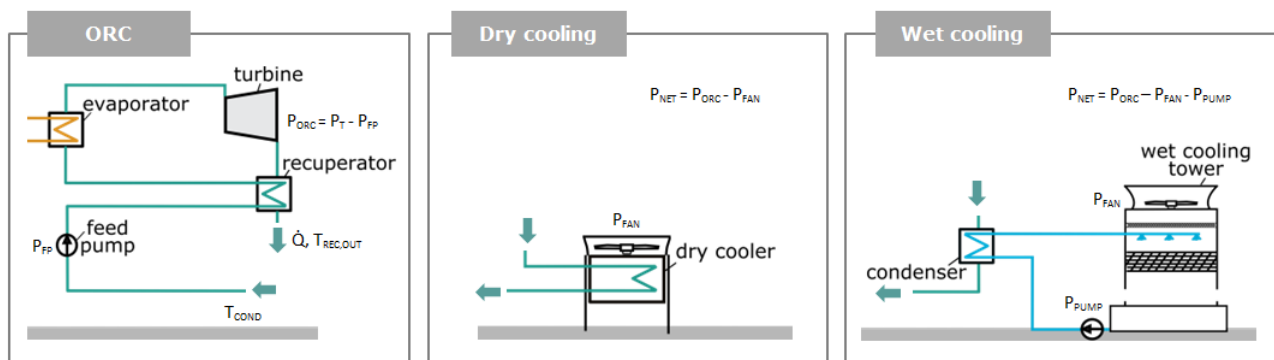

**Figure 2: Set-up of an ORC applying dry cooling with an air-cooled condenser and wet cooling with a wet cooling tower.**

Electricity generation using low temperature heat sources is characterized by relatively low conversion efficiencies and high amounts of waste heat. In case cooling water in sufficient amount and quality is not available, which is the case at many sites, power consuming **cooling systems**, such as air-cooled condensers and forced-draft wet cooling towers need to be used. Designing such cooling systems it needs to be considered that low condensation temperatures which lead to a higher turbine power output can only be reached with high fan power and/or large cooling system sizes. In conclusion, power conversion cycle and cooling system should be designed together and not individually especially referring to those design parameters which effect the conversion and the condensation/cooling process. Since the cooling system is in many cases the largest surface component of a geothermal binary power plant and cost intensive, a reasonable cooling system size can only be determined by evaluating the resulting net power increase. Further information can be found in Kröger (2005) and Frick et al. (2015).

### 2. SITE DESCRIPTION

The Lahendong geothermal field is located at about 30 km south of Manado, in North-Sulawesi (Fig. 3 and Fig. 4). It is a hot water dominated geothermal system divided into two reservoirs. Twenty three wells have been drilled into these reservoirs reaching temperatures up to 350°C and dryness up to 80% in the southern area and up to 280 °C and 30% dryness, respectively in the northern part (Koestono et al. 2010). The first 20 MW single flash unit has been put into operation in 2001. Meanwhile four 20 MW units are in operation. Two more 20 MW units are under preparation in Tompasso (southern Lahendong) that will be commenced in 2017 after finishing the drilling of additional production and reinjection wells. The Lahendong geothermal power generation supported almost 40% of electricity demand in Manado. The electricity demand increases about 8-10% per year due to the increasing population. Some industries utilize captive power by using diesel fuel.

The binary power plant will use brine from well pad of LHD-5. The brine temperature is about 170°C corresponding to a separator pressure of 8.5 barg. The total mass flow will be about 110 t/h. The brine outlet temperature should be about 140 °C since it should be possible to inject the hot brine back into the reservoir in the western part of the geothermal system.

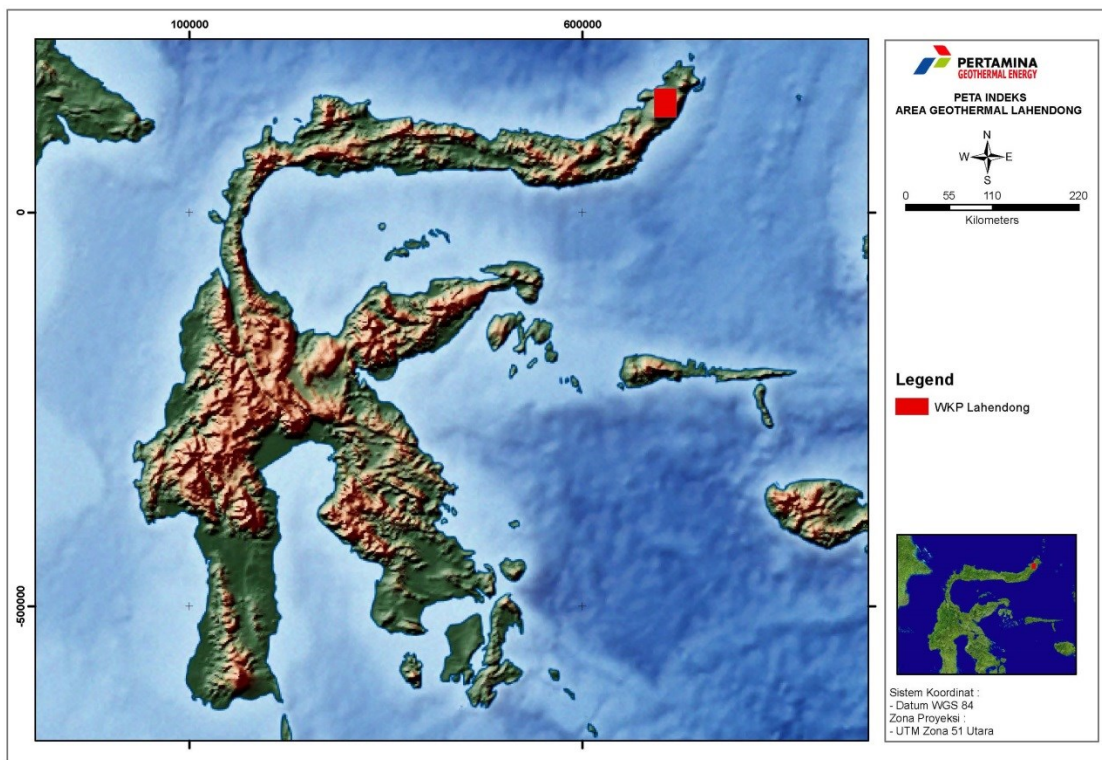

Figure 3: Location of the Lahendong geothermal field in North-Sulawesi



Figure 4: Area map of the Lahendong geothermal field

#### 4. PROJECT OUTLINE

The main project goal is the successful installation and operation of a geothermal binary power plant at the Lahendong site. The experience from planning, installing, operating and optimizing this demonstration power plant should then be transferred to other sites in Indonesia and should help to enable the deployment of binary power plants in the future. The scientific work objectives are directed to the systematic analysis and evaluation of all steps in the technical implementation of the binary power plant at the Lahendong site. Profound understanding of the processes within the brine loop, the binary cycle and the cooling equipment as well as their interaction and dependencies are prerequisites for the reliable and efficient use of binary power plants at any site.

The focus of the technical concept is put on plant reliability and low maintenance. The power plant cycle will be a subcritical, single-stage Organic Rankine Cycle (ORC) with internal heat recovery using n-pentane as working fluid. For low maintenance and high reliability of the ORC, no rotating sealing are used in the conversion cycle. The feed pump will be a magnetic coupled type. Turbine-stage and generator will be mounted in one body and are directly connected by the shaft.

From Fig. 5, which shows the technical concept of the demonstration plant, it can be seen that the ORC-module is not directly driven by the geothermal fluid since a water cycle between brine cycle and ORC will be used. Material selection and design of the primary heat exchanger can hence be based on the brine composition whereas the evaporator design can be optimized with focus on the thermo-physical characteristic of the working fluid. For the heat removal from the ORC to the ambient by means of air-cooled equipment, also an intermediate water cycle is planned in order to minimize potential risks of malfunction in the conversion cycle. Using a water-cooled condenser also has the advantage to facilitate a factory test of the complete ORC-module prior to the final installation at the site. Both intermediate cycles will lead to a loss in power output due to the additional heat resistance and the additional power consumption by the intermediate cycle pumps and entail additional costs. However, the gain in plant reliability was considered to outweigh the power loss for this demonstration project. An intermediate cycle on the hot side might, however, be also advantageous for other sites.

The installed capacity will be about 550 kWe. The auxiliary power consumption is estimated to be lower than 20%.

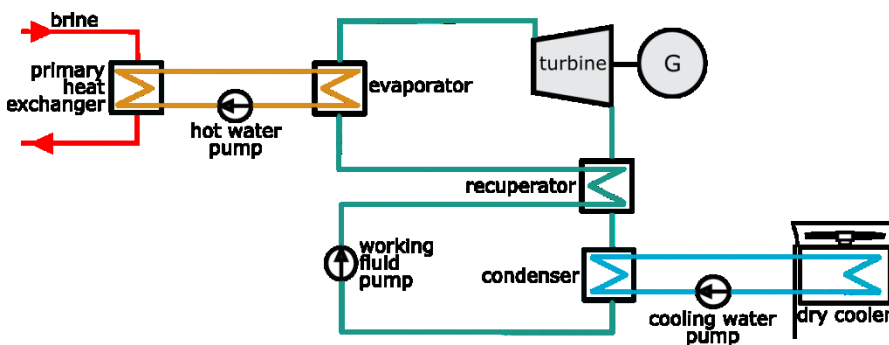

**Figure 5: Technical concept of the demonstration power plant**

The ORC-module has been specified by the project team according to the site conditions and the project goals. It will be constructed and delivered by an ORC manufacturer. The remaining components for integration of the ORC at site will be acquired from Indonesian suppliers, as far as possible. The project will be carried out in 3 phases:

- Phase 1: Site planning, construction ORC-module, site preparation, and test commissioning ORC-module (2014)
- Phase 2: Transport, installation and plant commissioning in Lahendong (2015)
- Phase 3: Demonstration, research and capacity building (2016)

**5. CONCLUSIONS**

A geothermal binary power plant will be installed at the Lahendong geothermal field. The focus of the technical concept is put on plant reliability and low maintenance. The commissioning of the plant is planned for the end of 2015 followed by a one year phase for demonstration, research and capacity development. The experience from planning, installing, operating and optimizing this demonstration power plant should be transferred to other sites in Indonesia and should help to enable the deployment of binary power plants in the future.

During the project course, project status, results and outcome of the project will be published.

**ACKNOWLEDGEMENT**

We would like to thank the Federal Ministry of Education and Research (BMBF) for project funding (Grants 03G0753A&B, 03G0834A).

**REFERENCES**

Erabs,K. et al., 2015. German-Indonesian Cooperation on Sustainable Geothermal Energy Development in Indonesia - Status and Perspectives. In *Proceedings World Geothermal Congress*. Melbourne, Australia.

Frick,S. et al., 2015. Improving the Annual Net Power Output of Geothermal Binary Power Plants. In *Proceedings World Geothermal Congress*. Melbourne, Australia.

DiPippo, R., 2012. *Geothermal power plants: principles, applications, case studies and environmental impact* 3rd ed., Butterworth-Heinemann.

Koestono, H. et al., 2010. Geothermal Model of the Lahendong Geothermal Field, Indonesia. In *World Geothermal Congress*. Bali, Indonesia.

- Sukhyar, R. et al., 2010. Geothermal Energy Update: Geothermal Energy Development and Utilization in Indonesia. In *Proceedings world Geothermal Congress*. Bali, Indonesia.
- Huenges E (Ed.) 2010. *Geothermal Energy Systems: Exploration, Development and Utilization*. Weinheim: Wiley-VCH.
- Kröger D 2005. *Air-Cooled Heat Exchangers and Cooling Towers: Thermal-Flow Performance Evaluation and Design*, Vol. 1. Oklahoma: Penn Well Corporation.